

RESTRICTED

AIR NAVIGATION



ARMY AIR FORCES TRAINING COMMAND



J. E. Vansin



AIR NAVIGATION

Published by the
ARMY AIR FORCES TRAINING COMMAND
Visual Training Department, from technical material
furnished by the
ARMY AIR FORCES INSTRUCTORS SCHOOL (Navigator)
Selman Field, Monroe, Louisiana.

To be used in conjunction with current AAF Training
Command memorandum covering Advanced
Navigation Training

RESTRICTED

NOTICE: This document contains information affecting the National Defense of the United States within the meaning of the Espionage Act, 50 U.S.C., 31 and 32, as amended. Its transmission or the revelation of its contents in any manner to an unauthorized person is prohibited by law.

ARMY AIR FORCES TRAINING COMMAND

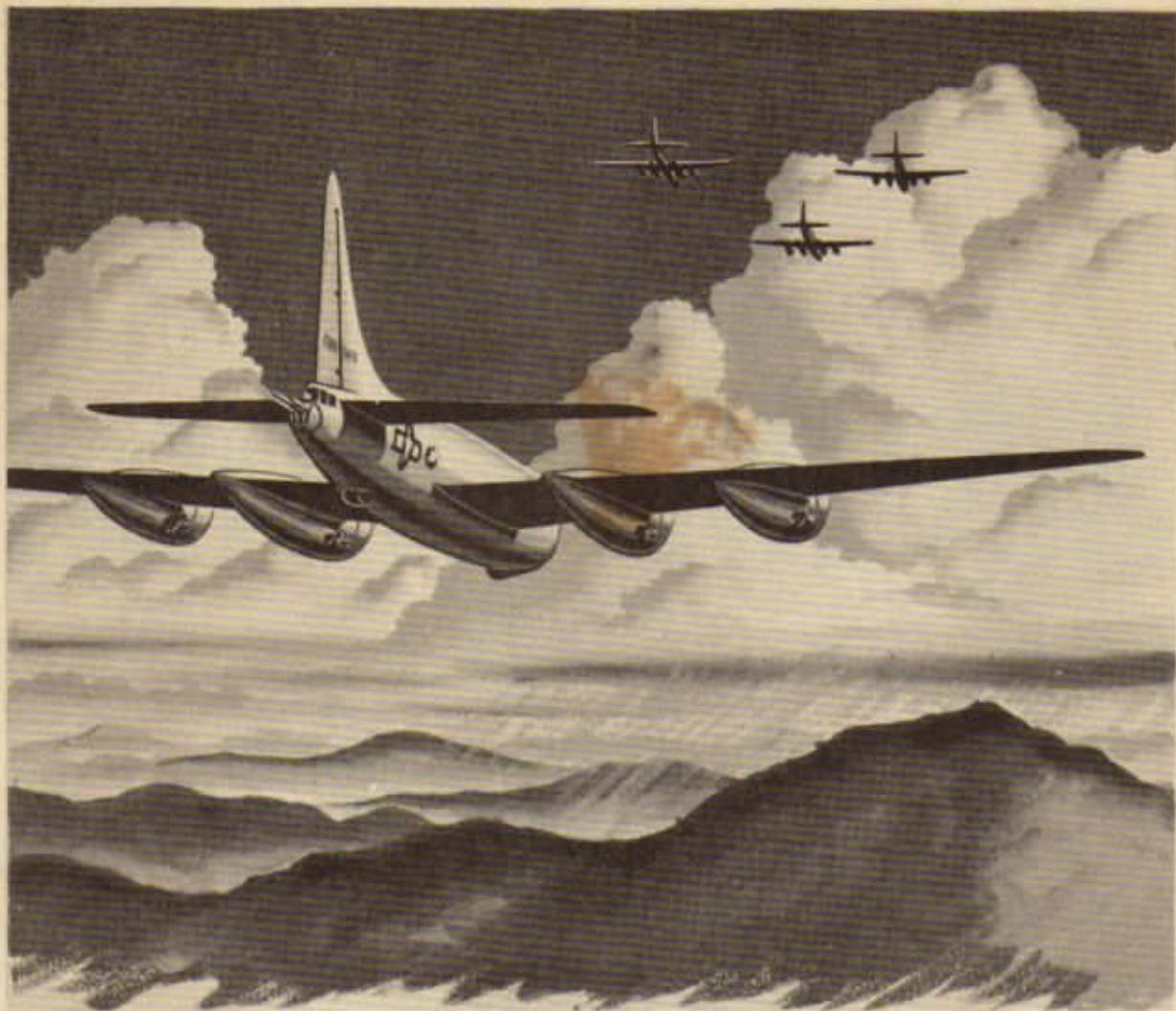

INTRODUCTION

Mankind lacks that sixth sense which seems to guide sea birds across thousands of miles of trackless ocean. Centuries of study have produced the great science of marine navigation, which enables mariners to overcome this handicap. But with the advent of air travel, new needs arose. The mariner, operating at limited speeds over comparatively limited areas, solves his navigation problem leisurely and with extreme accuracy. The airman, operating at high speeds and over vast areas, must solve his navigation problem very rapidly and with considerable accuracy. While it has gained much from marine navigation, aerial navigation rapidly

is taking shape as a distinct body of knowledge designed to meet the peculiar needs of air travel.

Many people have the impression that aerial navigation is an elaborate and formidable science, difficult to master. Actually, it is a clear-cut, logical, scientific art. It is true that the navigator must learn to do a number of things quickly and exactly, and that he must be thoroughly familiar with certain concepts not ordinarily encountered. But the operations and the concepts are logical and are easy to remember. Aerial navigation is not an abstruse subject derived from obscure reasoning based on complex

theorems. It is a sensible, practical application of simple scientific principles to the task of directing aircraft through the unmarked skyways.

An aerial navigator directs an aircraft from place to place over the surface of the earth, an art called *aerial navigation*. It presents a three-fold problem: (1) *determining course*, that is, determining the *direction* from *departure point* (starting place) to *destination*, (2) *keeping station*, that is, knowing as accurately as possible where the aircraft is *at all times*, and (3) *correcting course*, that is, finding the correction necessary to *maintain* (to stay on) a desired course, or finding at any time the course from wherever the aircraft may be to wherever it may be desired to take it.

Determining course consists of locating on a chart (map) and of measuring the direction between departure point and destination. *Keeping station* consists (1) of determining where the aircraft is at any time, either by positively locating it (as by looking at the ground) or by figuring where it must be by figuring the distance and direction flown from a known position, and (2) of predicting where the aircraft will be at any given time by figuring the distance and direction it will have flown at that time from a known position. The *clock time* (time of day) at which an aircraft is thus figured to reach any given point is called the *Estimated Time of Arrival* (ETA) for that point.

Correcting course consists of finding and applying the corrections necessary (1) to maintain a desired course, (2) to go into destination, or (3) to go into an *alternate*

(some other) destination. Corrections are made on the basis of information gained (1) by reading the navigation instruments in the aircraft, (2) by looking at the ground, (3) by making radio observations, and (4) by making celestial observations (observations of heavenly bodies).

The basis for solving the three-fold problem of navigation is *dead-reckoning*. Dead-reckoning is the art of determining, approximately, where the aircraft is or where it will be at a given time by figuring (reckoning) where it must be at that time because of the distance and direction flown from a known position. *Basic* dead-reckoning (no-instrument navigation) figures distance and direction flown without using navigation instruments. *Precision* dead-reckoning (instrument navigation) makes full use of navigation instruments.

The most skillful dead-reckoning can produce only a reckoned position which *must be checked* to be sure of an *actual* position. Dead-reckoning may be checked by three methods: (1) *map-reading*, (2) *radio observations*, and (3) *celestial observations*. Map-reading, that is, recognizing on the ground objects that are represented on the chart, provides an *exact* position and thus checks dead-reckoning. Radio and celestial observations properly made and interpreted provide a position accurate enough to compare with and to supplement dead-reckoning.

Dead-reckoning, either basic or precision or both, *must be done at all times*. It *must be checked* and supplemented *constantly* by map-reading, radio, and celestial observations.

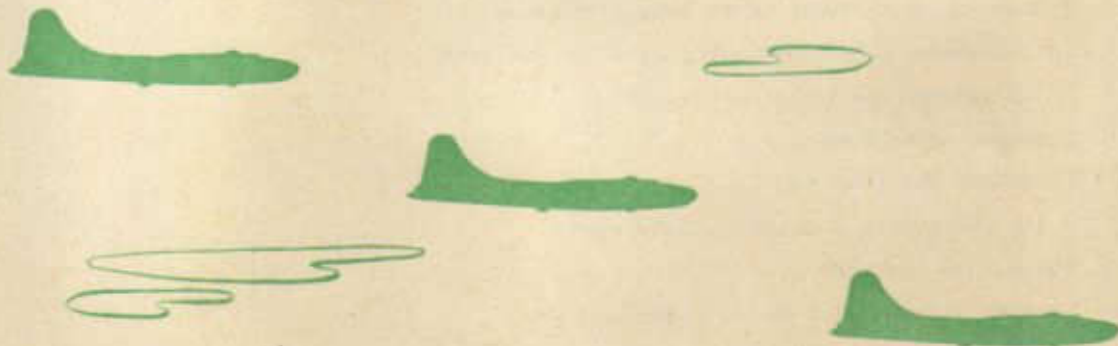



Basic Dead-Reckoning

OVERVIEW

I. BASIC IDEAS IN DEAD-RECKONING

A. The earth

1. Shape of the earth
2. Rotation of the earth about its axis
3. Location of the poles at the ends of the axis

B. The coordinate system of locating points on the earth

1. The equator and the prime meridian
2. Angular measurement
3. Latitude and longitude
4. The coordinates of a point on the earth

C. Direction on the earth

1. North, the reference for measuring direction
2. Departure point, destination, and course
3. Measurement of course

- D. Linear distance on the earth
 - 1. Nautical mile, statute mile, and kilometer
 - 2. Conversion of units of linear measurement

II. TOOLS USED IN BASIC DEAD-RECKONING

- A. Lambert conformal chart
 - 1. The problem of distortion
 - 2. Characteristics and desirable qualities of the Lambert conformal chart
- B. Map-reading
 - 1. Scale and date of chart
 - 2. Map symbols
- C. Plotting on the Lambert conformal chart
 - 1. Use of the platter and dividers
 - 2. Location of points
 - 3. Plotting and measuring courses
- D. Time-speed-distance problems: arithmetic, computer, and table solutions

III. BASIC DEAD-RECKONING TECHNIQUES

- A. Pre-flight preparation
 - 1. Chart work
 - 2. Selection of recognition- and check-points
- B. Determination of groundspeed (GS)
- C. Calculations of estimated time of arrival (ETA)
- D. Correction for off-course

IV. BASIC DEAD-RECKONING PROCEDURE

- A. Pre-flight procedure
 - 1. Preparation of charts
 - 2. Selection of recognition- and check-points
 - 3. Log of pre-flight information
- B. Procedure at take-off
 - 1. Check time and position
 - 2. Log procedure at take-off
- C. Keeping station
- D. Procedure at check-points
- E. Procedure to correct for off-course
- F. Procedure at destination
- G. Close-out procedure

EARTH'S SURFACE

Throughout the years, men have advanced many explanations of the beginning or origin of the earth. The theory most widely accepted at the present is that the earth was once a part of the sun. Due to some kind of disturbance, a part of the sun was thrown off and out into space. The thrown-off part was first a great, spinning ball of fire which gradually cooled. As it cooled, it formed an outer crust which has supported, first, vegetable, then animal, and, finally, human life. This cooled ball, still spinning, is the earth.

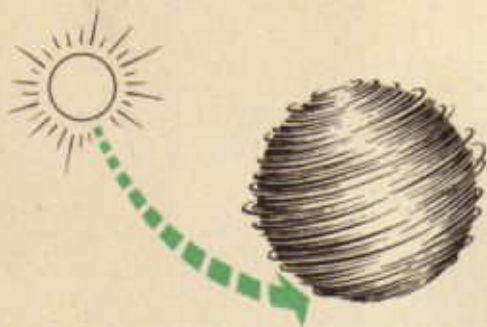

The earth, spinning in space, is spinning around an imaginary line within itself called its *axis*. The points on the surface of the earth at the ends of the axis are called *poles*, one being called the *north pole* and the other, the *south pole*.

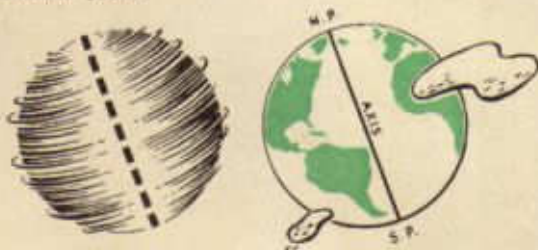

While the earth has been compared to a ball, it is not a perfect ball or sphere. A perfect sphere is a body whose surface is everywhere the same distance from a point within

the body called the *center*. In other words, a perfect sphere is perfectly round, like the classroom globe. The earth is not perfectly round; it is slightly flattened at the poles and slightly bulged around the middle. The amount of this imperfection can be judged when it is realized that the shortest distance through the earth, from pole to pole, is 7,900 miles, and the longest distance, through the bulge at the middle, is 7,927 miles, a differ-

ALL POINTS ON
A SPHERE ARE
THE SAME DISTANCE
FROM ITS CENTER



ence of only 27 miles. For all practical purposes, including navigation, therefore, the earth is considered to be a perfect sphere.



Man at first was very limited as to the distance he could travel on the earth and found his way round his limited world by landmarks or known positions. As methods of travel developed and as trading and commerce increased, it became necessary to have more accurate ways of locating points on the surface of the earth.



A very accurate system of locating points on the surface of the earth has been devised and is quite universally used. It is called the *coordinate system* and is not difficult to understand. The steps following will show, simply, how the system is set up and how it is used.



The first step is to take a slated globe and draw a circle around the very middle (half-way between the north pole and the south pole). This is the largest circle that can be drawn on the globe and is called, therefore, a *great circle*. The term, *great circle*, may be defined as the largest circle it is possible to draw on the surface of a sphere. This particular great circle, drawn half-way between the poles, is called the *equator*.

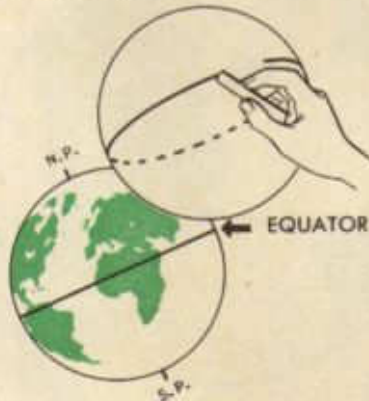

Notice here two things that mathematicians have found out about great circles:

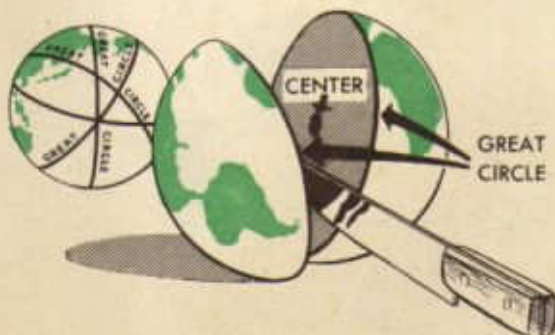

First, if a sphere, such as the earth, is sliced in two along any great circle, the sphere is cut exactly in half; therefore, the knife passes exactly through the center of the sphere. Second, the shortest distance between any two points on a sphere is measured on a great circle which includes the two points. These two facts are important and should be kept in mind.

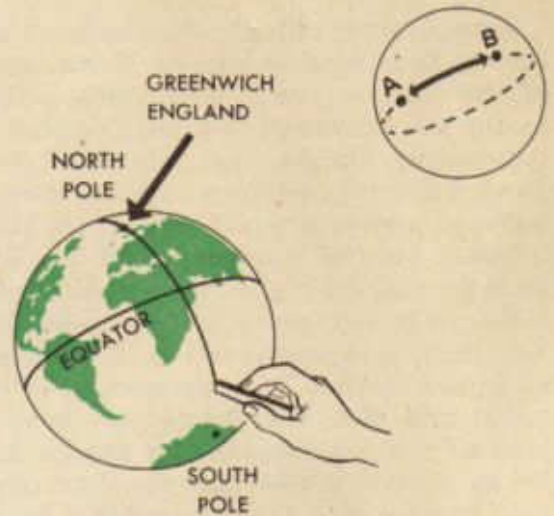

The second step is to draw a straight line from the north pole through Greenwich, England, which has been selected arbitrarily as the starting point, and to extend the line through the equator to the south pole. Such a straight line, drawn from pole to pole is called a *meridian* and is *half* a great circle. This particular meridian, which passes through the reference point of Greenwich, England, is called the *prime meridian*.

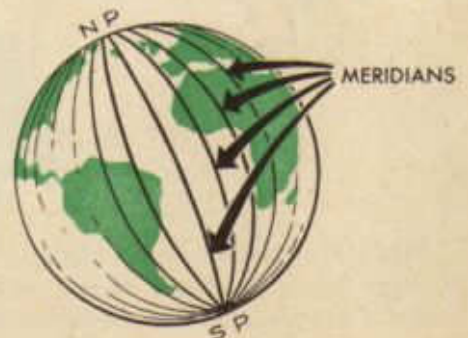

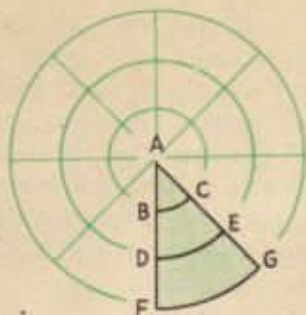

When dealing with circles, some very important facts must be learned. Examination of the diagram above shows three circles having the same center and each divided by the various straight lines into eight equal slices. Any circle, of course, could be divided into any number of equal slices in the same manner. Further examination of the diagram reveals that the line FG is much longer, in fact, is three times as long as the line BC. Yet, the line BC represents $\frac{1}{8}$ of the inner circle and the line FG represents $\frac{1}{8}$ of the outer circle. Note that the distance between lines AF and AG would be even smaller than BC on a circle smaller than the inner circle now drawn around A, and larger than FG on a circle larger than the circle now drawn around A. But that distance, large or small, always would represent $\frac{1}{8}$ of a circle around A. Thus is seen the difference between *linear measurement* (the actual length of the lines BC, DE, FG, etc.) and *angular measurement* (the fraction or part of a circle which the lines represent). This is a very important difference which must be kept in mind.

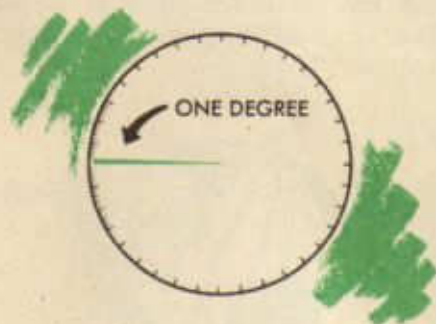

When a circle, however large or small, is divided into 360 equal slices, each slice is called a *degree*. For finer measurement, each degree may be divided into 60 equal slices, each of which is called a *minute*; and each minute may be divided into 60 equal slices,

each of which is called a *second*. Thus a degree is $\frac{1}{360}$ part of a circle; one minute is $\frac{1}{60}$ part of a degree or $\frac{1}{21,600}$ part of a circle, and a second is $\frac{1}{60}$ part of a minute, $\frac{1}{3,600}$ part of a degree, or $\frac{1}{1,296,000}$ part of a circle.

The third step in setting up the coordinate system is to divide the equator into 360 equal parts, beginning at the intersection of the equator and the prime meridian. The degrees on the equator then are numbered, 1 West, 2 West, etc., if they are on one's left as he stands on the prime meridian facing the north pole, and 1 East, 2 East, etc., if they are on his right. Observe that 180 W and 180 E are the same meridian, called, simply, the 180th meridian. There can be no number 181 or larger.

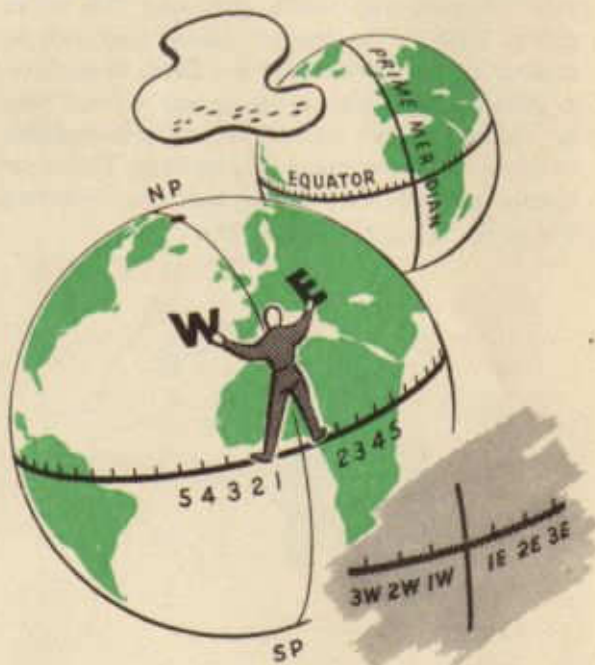

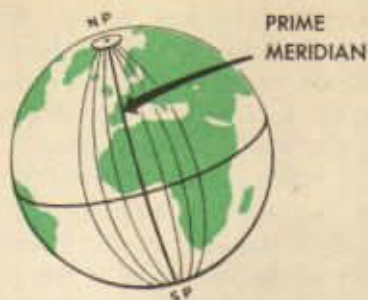

From the north pole draw or imagine meridians through each degree marked off on the equator, extending them to the south pole. Any number of meridians may be drawn in this manner, each of them being half a great circle.

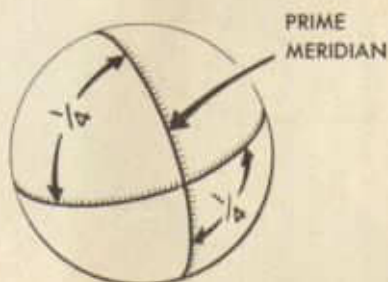

The next step is to divide the prime meridian, which is half a great circle, into 180 equal parts or degrees. It is observed that from the equator to either pole is $\frac{1}{4}$ of a circle or 90° .

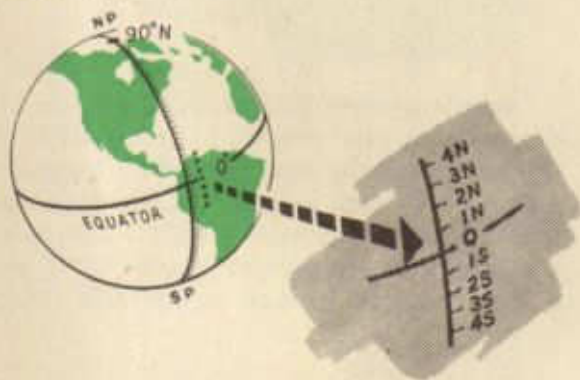

Therefore, the degrees are numbered from the equator, 1 N to 90 N if toward the north pole, or 1 S to 90 S if toward the south pole. Now it is possible to draw a line around the globe parallel to the equator through the point on the prime meridian marked 25°N or through any other point on the prime meridian. These lines are observed to be circles, but they are not as large as the equator. Hence,

they are not great circles, but are called *small circles*, which, by definition, are circles less than great circles on the surface of a sphere. The small circles already drawn are called *parallels of latitude*, and are numbered N or S in the same manner as the degrees on the prime meridian were numbered. Hence, the circle drawn through the point 25°N on the prime meridian, is numbered 25°N , etc. Any number of parallels of latitude may be drawn, each of them parallel to the equator and each of them a small circle.

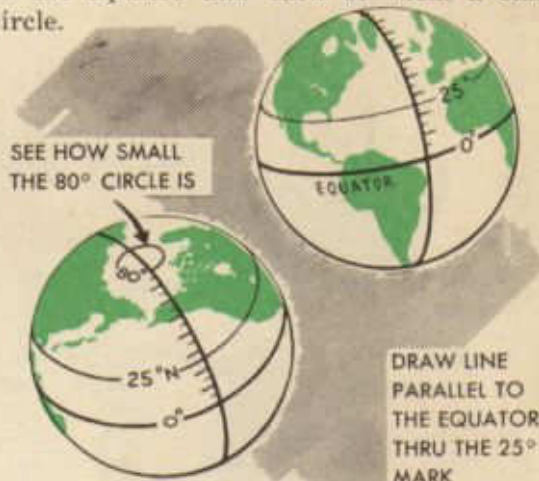

Remember now that degrees may be divided into minutes and seconds, that a parallel of latitude may be drawn parallel to the equator through any degree, minute, or second of the prime meridian, and that a meridian may be drawn from pole to pole through any degree, minute, or second on the equator. Now any point on the earth's surface may be located by:

1. Finding the number of the parallel of latitude that passes through the point, e. g., $30^\circ 20'\text{N}$.
2. Finding the number of the meridian that passes through the point, e. g., $96^\circ 30'\text{W}$. That point is referred to, then, by saying $30^\circ 20'\text{N}-96^\circ 30'\text{W}$.

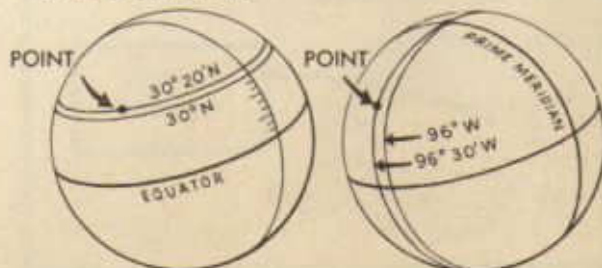

Angular distance (distance measured in terms of degrees, or fractional parts of a circle) north or south from the equator is called *latitude*, and generally is referred to by the abbreviation, *Lat.* or *La.* The angular distance east or west from the prime meridian is called *longitude* and is referred to by the abbreviation, *Long.* or *Lo.* In locating a point, latitude is given first; e. g., Lat. $30^{\circ}20'N$ -Long. $96^{\circ}30'W$, or simply $30^{\circ}20'N-96^{\circ}30'W$. These figures are called the *coordinates* of the point.

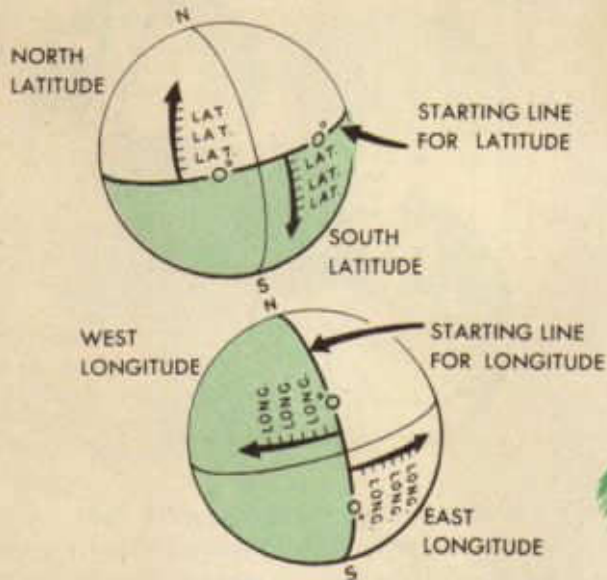

Note that positions equally distant north from the equator will be on the same parallel of latitude, regardless of their east-west location. For instance, a point $45^{\circ}N$ of the equator in the western hemisphere is on the 45th parallel north, and a point $45^{\circ}N$ of the equator in the eastern hemisphere lies on the same 45th parallel north. Points the same number of degrees east of the prime meridian will be on the same meridian, and points the same number of degrees west from the prime meridian will be on the same meridian, regardless of the north or south position in either case.

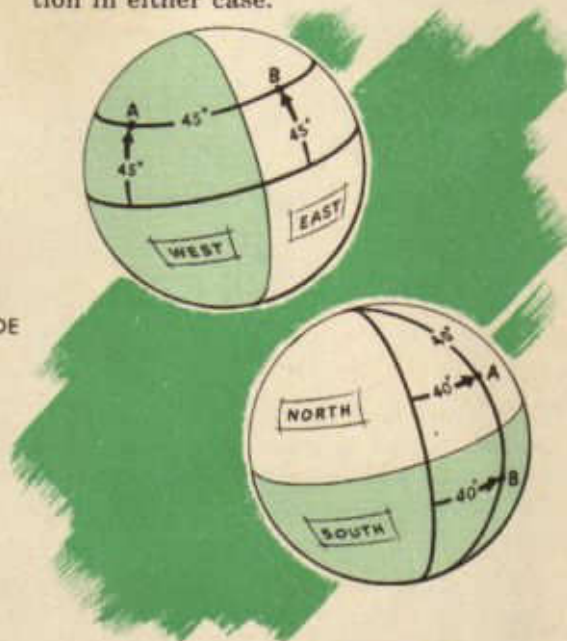

Consideration is given now to a method of determining and referring to direction on the surface of the earth. Consider any point on the earth such as point M. Through that point will pass a parallel (WE) whose number may be determined, such as $32^{\circ}30'N$, and a meridian (NS), such as $96^{\circ}20'W$. Thus

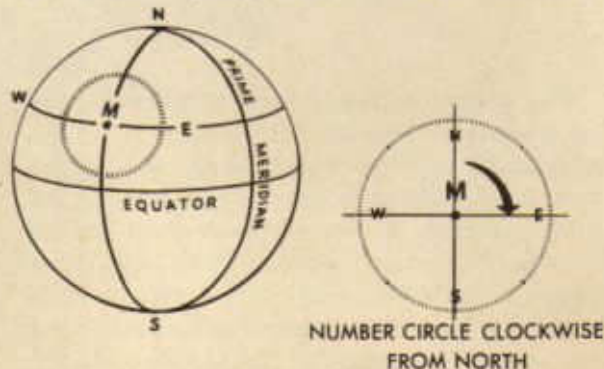

TO LOCATE A HOUSE IN THE CITY YOU MUST KNOW ITS ADDRESS

SO IT IS WITH LOCATING A POINT ON THE EARTH. THIS ADDRESS IS CALLED THE COORDINATES

$30^{\circ}20'N$
 $96^{\circ}30'W$

point M is located by saying $32^{\circ}30'N-96^{\circ}20'W$. Around point M imagine a circle, such as is drawn in the figure. This circle is divided into 360 equal parts or degrees, and perhaps further divided into minutes and seconds. These divisions begin with 0° at the north and move clockwise (as the hands of a clock move) through 360° . Thus $\frac{1}{4}$ around the circle from north, at the point usually called east, is 90° ; $\frac{1}{2}$ around, at the south, is 180° ; $\frac{3}{4}$ around, or at the west, is 270° ;

and all the way around, back to the north again, is 360° . Thus north is either 360° or 0° , but it is referred to usually as 0° . The direction from M to another point, Q, is described by telling the number of degrees on the circle between 0° or north and a line joining M and Q, such as the dotted line MQ, counting clockwise from north. Therefore, the direction of Q from M is 25° . Likewise, the direction of points S from M is 100° , point P from M is 260° .

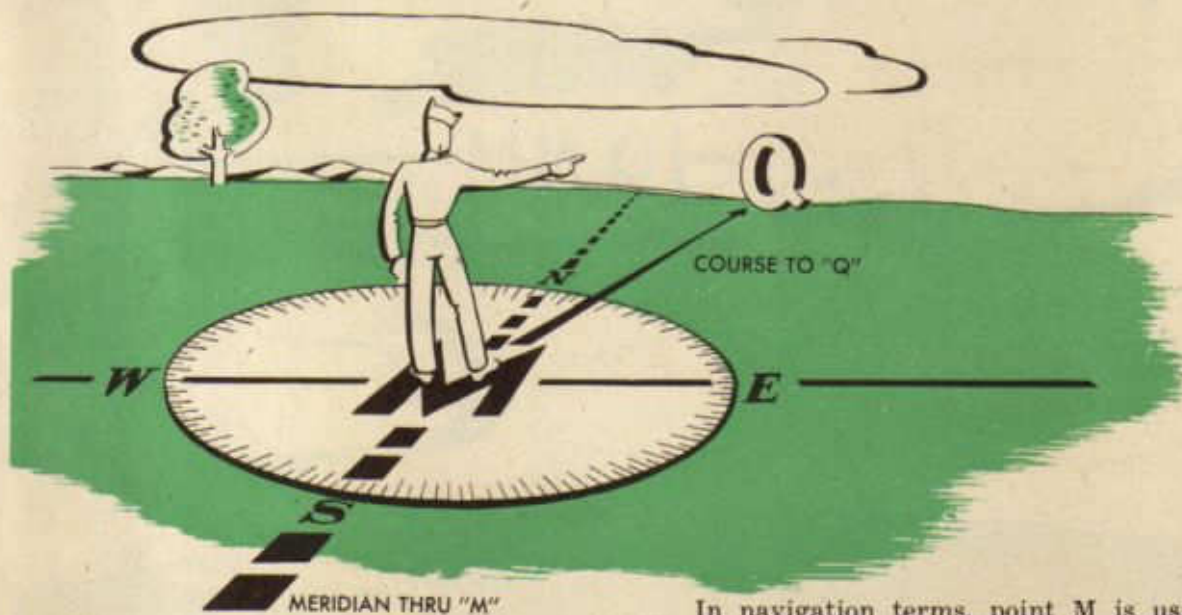
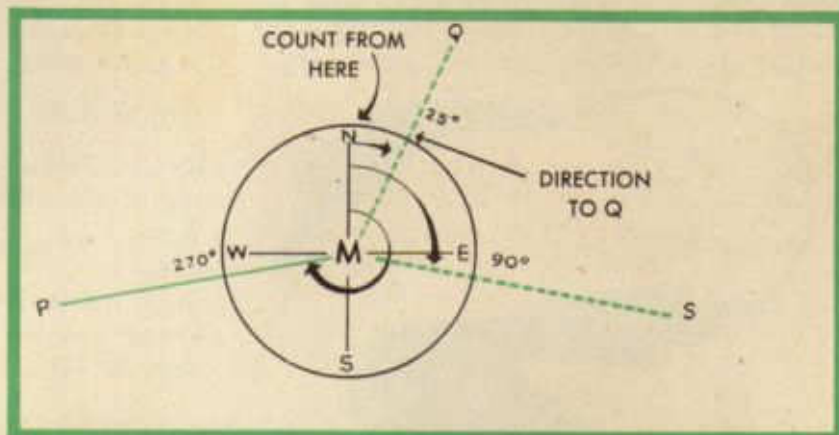

In navigation terms, point M is usually referred to as the *departure point*, and the other point, Q, S, or P, as the *destination*. The direction, expressed in degrees, is called the *course*.

Having now a system of location, latitude and longitude, and a system of direction expressed in degrees, the navigator needs a system of linear measurement. Remember that the equator was divided into 360° and that each degree may be divided into 60 minutes, making 360 x 60, or 21,600 minutes on the entire equator, which is the entire distance around the earth, east and west. Likewise, any pair of meridians comprising a great circle may be divided into 21,600 minutes which is the entire distance around the earth, north and south. Now, if the earth is considered a perfect sphere, the distance around the earth east and west and the dis-

tance around north and south are the same. And one minute on the equator or on a meridian or on any other great circle on the earth would measure off 1/21,600th part of the distance around the earth.

The distance represented by one minute of latitude or one minute of longitude at the equator, or one minute of any great circle, 1/21,600th part of the distance around the world, is called a *nautical mile*, and is the unit of linear measure generally used in navigation. How long is a nautical mile in terms of the more familiar units of feet or of ordinary miles, hereafter called *statute miles*? A nautical mile is 6,080 feet. Since a statute mile is 5,280 feet, a nautical mile is $\frac{6080}{5280}$ or 1.15 statute miles. Or another way of saying it, is that a statute mile of 5,280 feet is $\frac{5280}{6080}$ or .87 nautical miles. To change statute miles into nautical miles, divide by 1.15; to change nautical miles into statute miles, multiply by 1.15.



LAMBERT CONFORMAL

In the previous discussion, a method of locating positions on the earth's surface by giving the latitude and longitude (or the coordinates) of the point was presented. Since the earth is a sphere, it would be desirable to use a representation of the earth's surface on a sphere if that sphere could be

made large enough to be practical. However, when a spherical representation of the earth is large enough to be usable for navigation purposes, the representation is much too large and bulky to be used in a plane. Experience has shown that some method of representing the earth's surface on a flat surface is necessary for use in navigation. Such a representation is a *map* or *chart* and, in navigation, the terms *map* and *chart* mean the same thing.



When one tries to represent a portion of a sphere (which has three dimensions: width, length, and thickness) on a flat surface (which has only two dimensions: width and length), considerable difficulty is encountered, chief of which is *distortion*. The cause of distortion may be illustrated by trying to press half a grapefruit peel flat. As it flattens, it splits at the edges and tends to crease in the center. This splitting and creasing represents exactly what would happen if one

were to take a part of the earth's surface and try to flatten it out on a flat surface. Charts are constructed so that there are no breaks or blank spaces. Therefore, certain portions of the area represented by the chart have to be spread out in order to have the area represented cover the chart completely. This spreading out of areas so as to cover the chart is distortion. The amount of distortion on a chart depends upon the method of construction (the method of projection) of the chart. Charts are constructed by chart-makers, chiefly by the use of mathematical rules and formulas. This complicated construction is of small concern to navigators and will be considered very little in this course.

"PEEL" THE EARTH—
IT LOOKS LIKE THIS



A MAP HAS NO BREAKS OR BLANK SPACES.
SPREADING TO FILL THE SPACE CAUSES DISTORTION

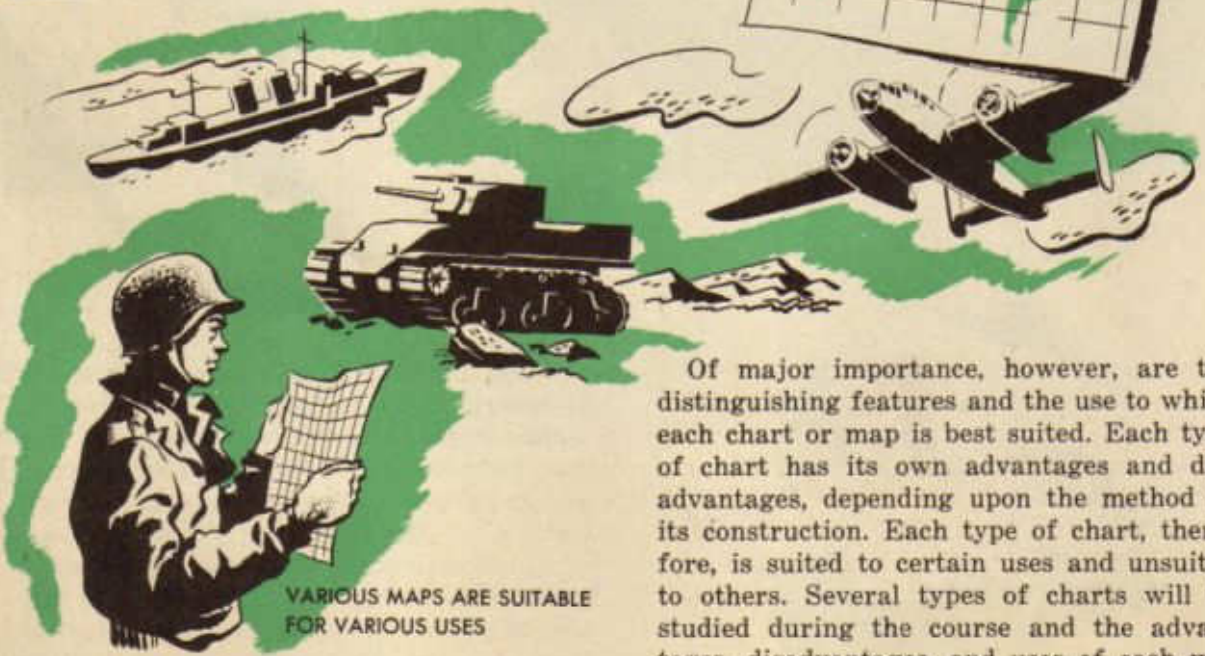

VARIOUS MAPS ARE SUITABLE
FOR VARIOUS USES

Of major importance, however, are the distinguishing features and the use to which each chart or map is best suited. Each type of chart has its own advantages and disadvantages, depending upon the method of its construction. Each type of chart, therefore, is suited to certain uses and unsuited to others. Several types of charts will be studied during the course and the advantages, disadvantages, and uses of each will be pointed out.

The chart to be considered specifically at this time is the Aeronautical Sectional chart, a topographical chart on the Lambert Conformal Projection. Secure such a chart and examine it to see what can be found out about it. At first glance, it appears that the meridians are parallel straight lines and that the parallels of latitude are also parallel straight lines. The reason for this is that this chart is on a very large scale and a slight convergence (coming together) or curvature (curving) of lines may not be noticed without close examination. Comparison of the left-hand border line of the chart, which is straight up and down, with the first meridian on the left side of the chart reveals that the meridian is not straight up and down, but leans toward the center of the chart. Examination of the right edge of the chart and the first meridian on the right reveals that the right hand meridian also leans toward the center of the chart. This leads to the conclusion that the meridians are converging toward a point outside the chart toward the north. If dividers are spaced from one meridian to another at the bottom of the chart and moved slowly toward the north, it will be seen that any pair of meridians are closer together at the top of the chart than at the bottom. Therefore, it may be written as one descriptive fact about the Lambert Conformal chart:

1. The meridians are represented as non-parallel straight lines converging toward a common point in the direction of the pole.

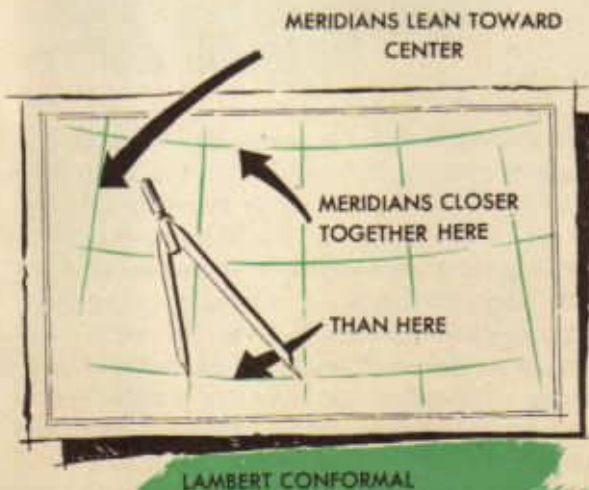

Next, examine the parallels of latitude. First, space a pair of dividers across any two parallels of latitude. Move the dividers along the lines and observe that the lines are everywhere the same distance apart, that is, they are parallel. Are the lines curved or straight?

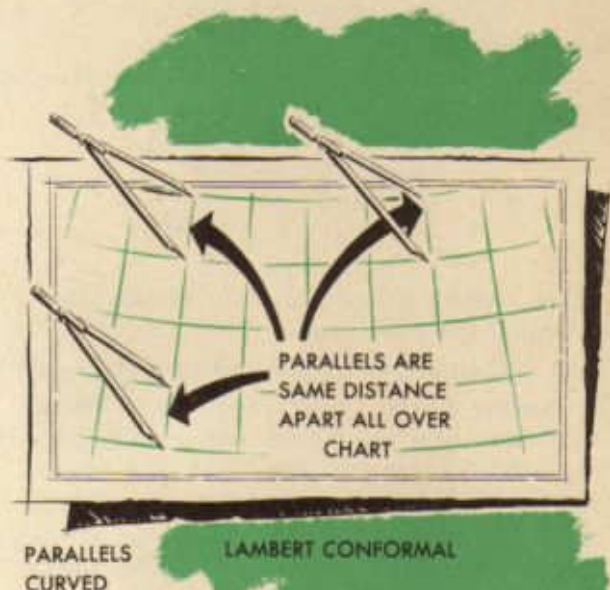

Look at the bottom border-line of the chart and compare it with the first parallel of latitude shown. Look also at the top border-line and the top parallel. It appears that the parallels curve. Check by applying a straight edge to several parallels. They all curve away from the pole. Since the lines curve, they must be parts of circles. Since the lines are parallel curves, they may be assumed to be parts of circles having the same center (concentric circles). Since the center of these circles seems to be toward the pole and since the intersection of the meridians seems to be toward the pole also, it may be that the center of the concentric circles and the intersection of the converging lines are at the same point. Chart-makers state that this conclusion is true; therefore, a second descriptive fact may be listed:

2. The parallels of latitude are represented as equally spaced, parallel, curved lines, the curves being portions of concentric circles

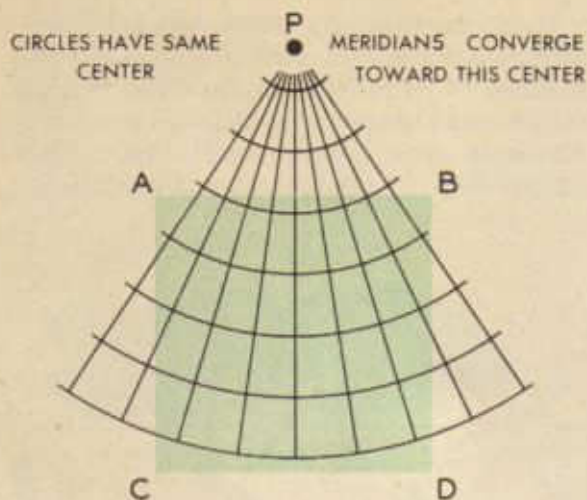

whose centers are at the point of the intersection of the meridians.

To extend all the lines found on a Lambert Conformal chart would result in a figure somewhat like the figure above. The section ABCD represents the chart. The meridians, extended, would intersect at point P. Point P is found also to be the center of the equally spaced concentric circles, which represent parallels of latitude.

What, now, are the advantages for navigation purposes offered by the Lambert Conformal charts? In the discussion on the earth's surface, it was pointed out that the shortest distance between two points on the earth's surface is along a portion of a great circle joining the two points. Navigation frequently is concerned with routes which should cover the shortest distance between two points (great circle routes). Hence, it is desirable that a great circle route be represented by a straight line on the navigator's chart.

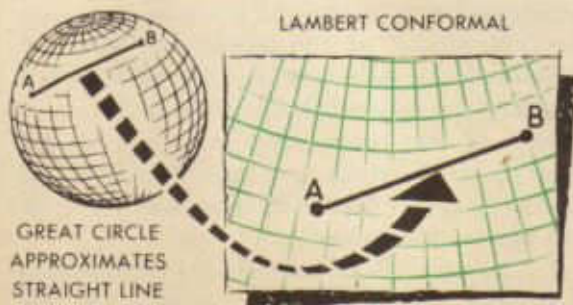

In the discussion on the earth's surface, it was pointed out that all meridians are great circles. It has been noted in the examination of the Lambert Conformal chart that all the meridians are straight lines. Might not all great circles be represented as straight lines? Such an assumption is approximately true, so it may be written as an advantage of Lambert Conformal charts:

1. A great circle is approximately a straight line on Lambert Conformal charts.

The desirability of a constant distance scale is apparent. It is much easier to measure distances on a chart if the scale is the same all over the chart. In the discussion of the earth's surface, it was pointed out that one nautical mile is the distance represented by one minute of latitude. Examination of the Lambert Conformal chart reveals that

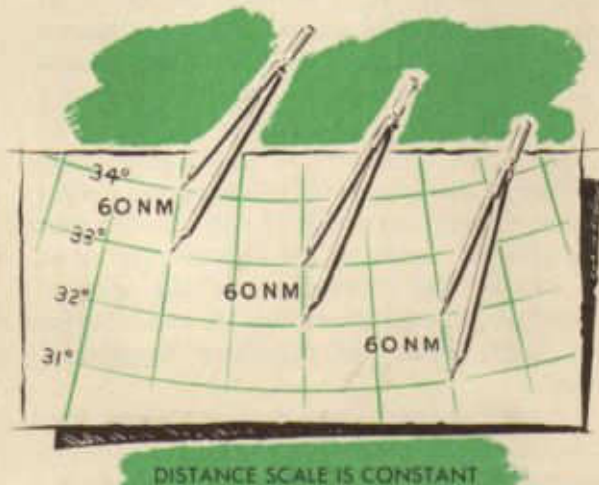

the curved lines representing latitude are equally spaced. This means that a minute of latitude is the same length anywhere on the chart. Since a minute of latitude is a nautical mile, a nautical mile is represented by the same distance anywhere on the chart. The distance scale, then, is the same anywhere on the chart, or is, in other words, constant. Therefore, it may be written as a second advantage of Lambert Conformal charts:

2. The distance scales on Lambert Conformal charts are constant scales.

Positions on the earth's surface, represented by giving their coordinates, should be easy for the navigator to plot. Such plotting is most easily done on a chart which has a perfect *grid system* (straight lines intersecting at right angles) for representing latitude and longitude.

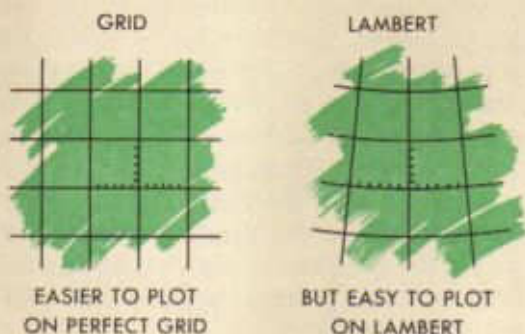

The Lambert Conformal chart, with its converging meridians and its curving parallels of latitude, does not have such a perfect grid system. While positions are easily plotted on a large scale Lambert Conformal chart, they are only fairly easily plotted on charts of smaller scale. But, for practical purposes, it should be written as a third advantage of the Lambert Conformal chart:

3. Positions are easily plotted on Lambert Conformal charts.

Areas should retain the same shape, characteristic appearance, and proportionate size on the navigator's chart that they have on the earth's surface. Experience in the air will verify the chart-makers' statement that

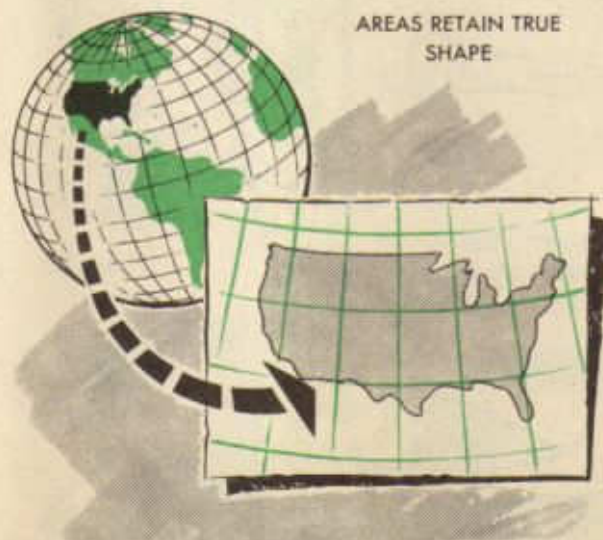

Lambert Conformal charts meet this requirement. This means that distortion is slight, so slight in fact as to be negligible. Therefore, it may be listed:

4. Areas retain the shape, characteristic appearance, and proportionate size on Lambert Conformal charts that they have on the earth's surface; distortion is negligible.

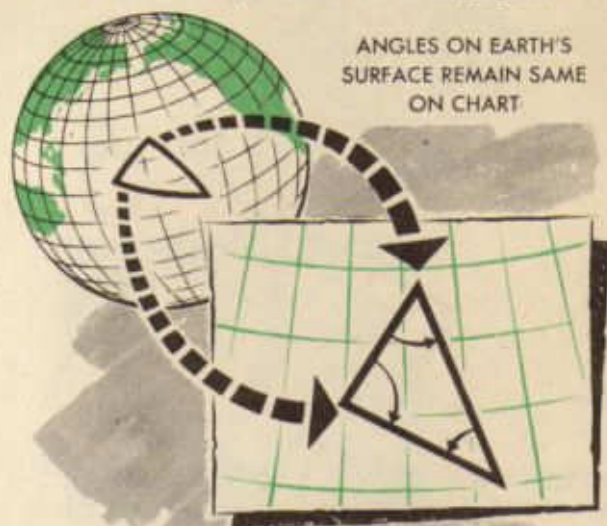

Angles on the earth's surface should be shown as the same angle on the chart. Mathematicians have found that this requirement is met by Lambert Conformal charts; therefore, it may be listed:

5. Angles on the earth's surface are shown as the same angles on Lambert Conformal charts.

Students of navigation and navigators in the Air Forces will encounter quite frequently four series of Lambert Conformal charts. These may be listed, with some information about them, so that they may be recognized when they are encountered.

NAME	NUMBER IN SERIES	CHIEF USE
Sectional	87 for U.S.	Map-reading
Regional	17 for U.S.	Planning longer flights
Radio Direction Finding (R.D.F.) Chart	6 for U.S.	Radio
Aeronautical Planning Chart	1 for U.S.	Planning longer flights

MAP READING



TO READ BOOK
YOU MUST
KNOW ALPHABET-
TO READ MAP
YOU MUST
KNOW SYMBOLS

trained to read the chart, that is, to recognize and to interpret the symbols found on the chart and from them to recognize the portion of the earth represented by the chart when he sees it. He also must be able to look at a portion of the earth's surface, to visualize the appearance of that portion on a chart, and to locate that portion of the earth's surface on a chart. He must be able, in other words, to go from the chart to the earth or from the earth to the chart. He then is able to locate the position of his ship at any time he can see the ground, provided he has a chart of the region.

Realizing the importance of charts to aviation, Congress, in the Air Commerce Act of 1926, provided for the publication of aviation maps necessary for safety in flying. At that

In the discussion of the Lambert Conformal chart, it was pointed out that a map or a chart is a representation of a portion of the earth's surface on a flat surface. It was pointed out also that among the charts used by navigators in the Air Forces is the Sectional Aeronautical chart, a Lambert Conformal chart. This chart, in common with other charts, is a small scale representation of a portion of the surface of the earth and of whatever may be on it. The chart presents to the trained eye a description of the charted region, picturing the landmarks and presenting other information which has been found to be of value to aircrew members.

But in order to gain the information contained on the chart, the navigator must be



NAVIGATOR
MUST GO FROM
MAP TO GROUND

and

FROM GROUND
TO MAP

LEARN TO DO BOTH

time there were no suitable charts available which covered the country as a whole. A new type of map, especially designed to meet the needs of a new industry, was urgently required.

In order to satisfy the most immediate and pressing demands, strip charts of the principal airways were published. It was realized soon, however, that strip maps could not meet the need and in 1930 the first edition of the Sectional Aeronautical charts was published. Although very favorably received, these first charts were little more than topographical charts, showing the characteristics of the terrain. With the development of more advanced methods of navigation, features of the charts once thought essential were replaced by features found to be of more importance. Changing conditions of flight, such as higher speed, longer flights, and higher altitude, are almost certain to result in revised methods in navigation which will necessitate further changes in the charts.

No charts, then, can be considered finished pieces of work. Changes are made constantly over the sections of the earth covered by the charts, necessitating constant revision. Roads are changed, new roads are built, towns spring up. Changes often come about so rapidly that a navigator using an out-of-date chart may become lost. For that reason, there is printed in red in the lower left-hand corner of each sectional chart the date of the chart followed by a note of warning:

Consult "Weekly Notices to Airmen" at your local airport for changes occurring in aeronautical information on this chart after—
 (Date)

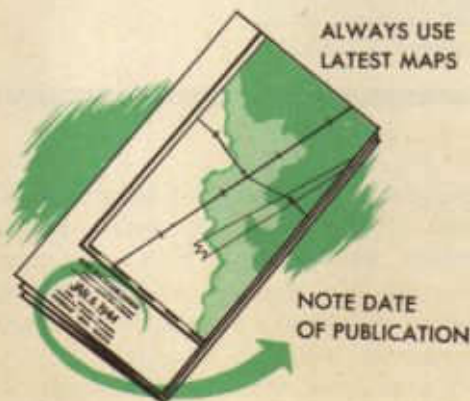

Of major importance in the use of any chart is a consideration of the scale of the chart. The scale of a chart is the proportion to which it is drawn. On the Sectional chart, one inch on the chart represents 500,000 (half million) inches on the earth's surface. The Sectional chart has, therefore, a scale of 1 : 500,000, and this fact is noted on the upper right-hand corner of each Sectional by the note, Scale 1 : 500,000. Other charts employ other scales, such as 1 : 250,000 or 1 : 1,000,000. Another way of expressing the scale of a chart is to give only the distance on the chart which represents one statute mile on the earth's surface. *Quarter-inch scale*, for instance, means that one quarter-inch on the chart represents one statute mile on the earth's surface. Charts often are referred to by scale rather than by name. The British, for example, generally refer to the Sectional charts as "half million" charts or

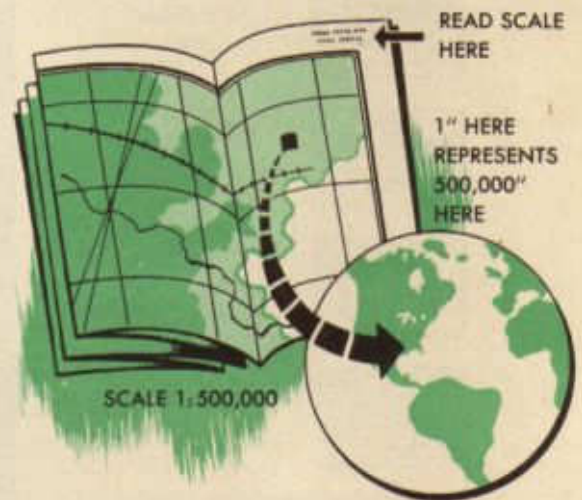

to certain other charts as "quarter-inch" charts. The scale of any chart should be kept in mind when using the chart.

Mention has been made of reading the chart. Reading the chart is made possible by a system of symbols called *map symbols*. These symbols resemble, but do not picture the objects represented. Usually they are exaggerated in size so as to be clearly visible on the chart. Many objects on the ground which are not represented on the chart will be visible to the navigator at average flight altitude. It would clutter up the chart too

much to try to represent every object on the chart; so only the objects found to be the most useful to the navigator are represented.

The navigator will find, too, that many objects represented rather prominently on the chart will be barely visible from the air. This is especially true of radio stations, for instance. Such objects are important to the navigator for reasons other than their visibility. For example, the navigator can tell direction by means of a radio station and his radio equipment; therefore, it is extremely important that he know where the station is located.

Notice that the water feature symbols are in blue. The ocean is of great importance and the coast line is accurately represented. Lakes are represented rather accurately as to size and shape. Permanent lakes are represented by solid blue; intermittent lakes by diagonal blue lines enclosed by a broken line outline of the shape of the lake at its high-water mark. Dry lakes are represented by a broken line outline of the original shape of the lake, filled in with brown dots.

Large rivers are represented by double blue lines shaded between in light blue, following closely the actual course of the river.

BODIES OF WATER ARE IMPORTANT



CULTURAL (MAN-MADE) FEATURES

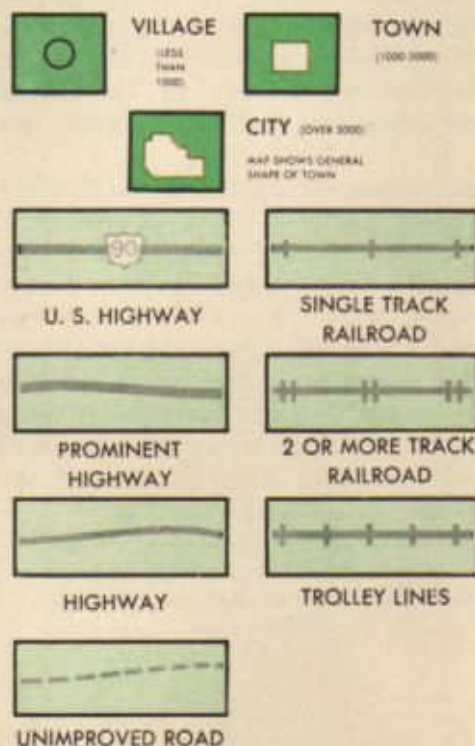

Bodies of water are, to the navigator, the most important of the visible objects. They are clearly visible by day and are generally visible by night. They change as little as any other group of objects. Therefore, the symbols for water features are of prime importance.

Streams are represented by single solid blue lines if they are permanent streams; by broken blue lines if they are intermittent streams. Marshes are represented by symbols of small tufts of grass on scattered short horizontal lines, all in blue.

Cultural or man-made features also are

highly important. Of the cultural features, towns and cities are of first importance. Villages of less than 1,000 population are represented by small black circles; towns between 1,000 and 5,000 by small yellow squares bordered in brown. Cities of over 5,000 population are represented by a brown-bordered, yellow figure outlining the shape of the city.

Highways and roads are represented in purple. Designated U. S. highways are denoted by a heavy purple line with a shield containing the number of the highway occurring at intervals. Other prominent highways are represented by the heavy purple line only and less prominent highways or roads, by light or thin purple lines.

Single track railroads are represented by heavy black lines with a short cross-tie mark every five statute miles. Double and multi-track railroads are represented by lines with double cross-tie marks every five statute miles. Abandoned railroads are represented by broken black lines with cross-tie markings. Trolleys are represented in the

MISCELLANEOUS CULTURAL FEATURES

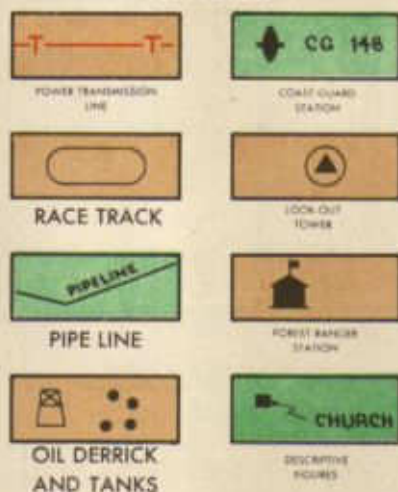

same manner as are railroads except that the cross-tie marks are only $2\frac{1}{2}$ statute miles apart.

A group of miscellaneous cultural features also are often encountered. They are all in black except those which present a menace to aerial travel, which are in red.

The more prominent transmission lines are dangerous to air traffic; therefore, they are shown in red as a thin line broken by T's. The race track symbol is the typical race track oval in black. Pipelines, important

RELIEF FEATURES



GRADIENTS OF ELEVATION



TERRAIN LEVELS



PEAK HACHURED



WATER LEVEL LINE

because of the right-of-way scars usually visible, are shown as thin lines with the word, "pipeline", written under them at intervals. Derricks and oil storage tanks are represented by typical symbols covering approximately the area covered by the derricks or tanks, but not representing the number. Coast guard stations are shown as small, black, boat-like figures and the letters C. G., followed by the number of the station. Look-out towers are represented by a small black triangle encircled by a black circle; forest ranger stations, by a small station-hut with pennant atop. Also on the Sectional will be noted many descriptive notes, describing and pointing out landmarks. Water tanks, churches, etc., are pointed out in this manner.

Certain relief features are shown on the Sectional chart. The elevation of the section covered by the chart is denoted by a system of coloring, ranging from medium green, which denotes elevation between sea-level and 1,000 feet, through nine shades or colors to dark tan, representing elevations above 9,000 feet. Light brown contour lines joining points of equal elevation serve as border lines between the various colors. Prominent elevations or peaks are denoted by short, radiating (hachured) brown lines, usually with the elevation denoted by figures. Black

dotted lines drawn off the shore line indicate three-foot water depth. On later charts this line will denote ten-foot water depth.

AERONAUTICAL FEATURES

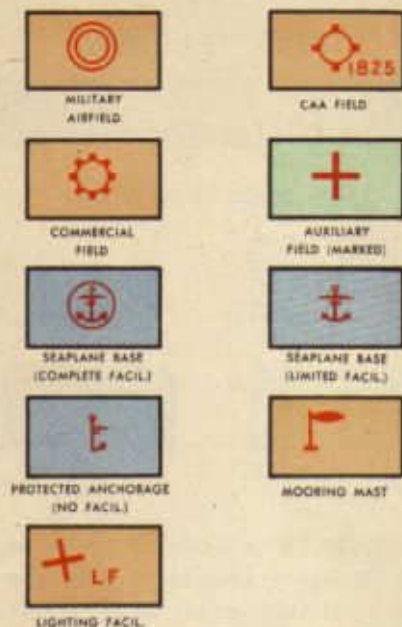

Certain features of peculiar importance to aeronautical navigation are shown in red on the Sectional. Airports, lights and beacons, radio stations, civil airways, and miscellaneous features are thus indicated.

Military airports, Army, Navy, or Marine Corps, are represented by two concentric circles. Commercial or municipal airports are indicated by a single circle bounded by eight small squares. C. A. A. intermediate fields are shown as single circles bounded by four

LIGHTS AND BEACONS

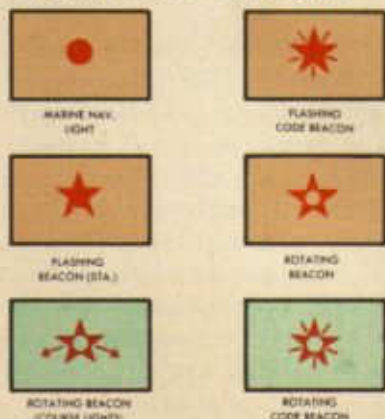

small squares; marked auxiliary fields, by a red cross. The name of each airport is noted nearby and the altitude is indicated by slanting red numerals. Seaplane bases with complete facilities are represented by an anchor enclosed in a circle; seaplane anchorages with refueling and limited facilities, by the anchor only. Protected anchorage with no facilities is denoted by one side or one half of an anchor. A mooring mast is indicated by a small symbol representing a dirigible moored at mast. The letters LF denote lighting facilities.

Lights and beacons are of prime importance to navigators on night flights and for that reason such features are prominently shown in red on the chart. The Marine navigational light is shown as a solid dot. The flashing beacon (stationary) is denoted by a solid red star; short radiating lines are added to the solid star when the beacon has flashing code lights. The rotating beacon is

RADIO SYMBOLS



represented by a red star with a white circle in the center. Red arrows pointing up and down the course are added when the rotating beacon has course lights, and short radiating lines are added when the rotating beacon has flashing code lights. In summary, the solid star represents a stationary beacon; the star with the white circle in the center, a rotating beacon. Short radiating lines represent flashing code lights and red arrows represent course lights. There may be several combinations of these symbols.

As has been indicated heretofore, radio stations are of great importance to the navigator. All radio symbols are in red. The commercial station is represented by a small red circle with a dot in the center followed by the letters RS. Nearby is an eight-sided box in which is written the call letters and the frequency of the station. The radio range stations (the beam stations) are represented by the circle and dot with the beams represented by widening lines radiating from the station in the directions in which the beams actually extend. In a box nearby is listed the name, the call letters, and the frequency of the station together with other pertinent information.

The radio direction finder station (the *RDF* station) is represented by the circle and dot followed by the letters *RC*. The frequency of the station and the call letters are in a six-sided box nearby. The Marine radio beacon is denoted by the circle and dot followed by the letters *RBn*, with the frequency and identification signal listed in a six-sided box nearby.

The radio marker beacon is represented by a solid red dot or circle of considerable size. The frequency and identification are listed in a box adjoining the circle. The fan marker beacon is denoted by a symbol somewhat like a long, narrow football. All these stations and their functions will be described fully in the sections on radio navigation.

Of importance to navigators are certain air lanes over the country which have been designated by a color and a number. For example, the airway over the city of San Antonio is Amber Airway No. 4. These airways are represented on the chart by two heavy red lines twenty statute miles apart if air traffic on the airway is restricted or controlled, or by two pairs of light red lines twenty statute miles apart if the traffic is not controlled.

There are several miscellaneous symbols representing other features of peculiar importance to aerial navigation.

An obstruction is marked by a red inverted V and a numeral representing the height of the obstruction. A restricted area, over which a plane must maintain a certain minimum altitude, is outlined by short diagonal red lines, and a note, giving the minimum altitude to maintain, is nearby. An airspace reservation, an area over which flight is forbidden, is represented by red diagonal lines across the entire area. Unmarked explosive areas are designated by the symbol of a flame on a circle. Isogonic lines, lines of equal magnetic variation, are represented by broken lines; a numeral representing the amount of the variation appears at intervals.

MISCELLANEOUS SYMBOLS



OBSTRUCTION



CAUTION AREA



DANGER AREA



UNMARKED EXPLOSIVE AREA

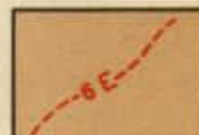

ISOGONIC LINE

PLOTTING

The student of navigation is confronted with many new and unfamiliar ideas and materials. Among those already introduced is the Lambert Conformal or sectional chart used by the navigator. It was mentioned at the time of presentation that the navigator was primarily interested in location, direction, and distance.

In solving the problems of location, direction, and distance, the student will have occasion to do *plotting* (drawing) on his chart. In the course of this plotting, he will use two or three *plotting instruments* (drawing instruments).

Most important and most used of the plotting instruments is the *plotter*; often called the Weem's Plotter, the Aircraft Plotter, the Department of Commerce Plotter, or the Mark II Plotter. By whatever name it is called, it is a very useful instrument in the hands of a navigator. The plotter is designed especially for use with aeronautical charts and can replace the protractor, dividers, and parallel rules. However, time can be saved by using both plotter and dividers.

The ruler portion of the plotter is covered with various scales. The outer and vertical scales correspond to statute miles on regional charts. The inner scales correspond to statute miles on sectional charts. The straight edge is used as a ruler for drawing course



THE PLOTTER

lines. The semicircular portion is designed for measuring courses according to the direction of flight as indicated by the two arrows. It is graduated to facilitate reading to one-half degree. The plotter should never be used as a protractor, since much time would be lost.

A word needs to be said about the very common instrument, the *dividers*. Dividers are to be used with *one hand only*. If they are too stiff to operate with one hand, the tension stud, noted in the drawing, must be



adjusted. The drawing shows the correct position of the thumb and fingers. The thumb and hand must be kept out of the line of vision so that the points always are clearly visible. When the dividers are opened or closed, one blade is kept pressed against the palm of the hand by the third and little fingers and the other blade is moved by the middle and index fingers. *Avoid using both hands* to operate the dividers.

Various types of transparent triangles may be used in navigation plotting. The two most usually encountered are the 30°-60°-90° triangle and the 45°-45°-90° triangle.

In addition to the plotter, the dividers, and the triangles, several well-sharpened, soft-lead pencils and a very soft rubber or art-gum eraser will be needed. Hard-lead pencils

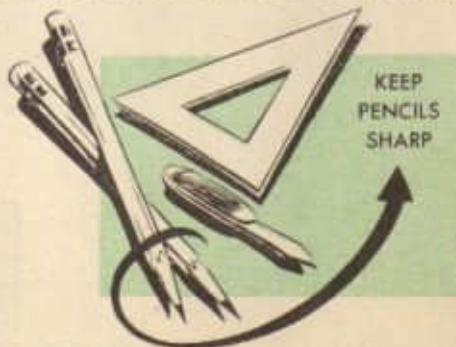

are to be avoided as well as ordinary rubber erasers. Hard-lead pencils make dim, hard-to-see lines that are difficult to erase, and ordinary erasers destroy charts when used on them.

One of the simplest plotting problems encountered in navigation is plotting positions. The straight edge of a plotter and the dividers are used to plot positions on the Lambert Conformal chart. Examination of the chart reveals that minutes are marked off for the measurement of latitude and longitude on the 30' lines between each pair of evenly numbered lines on the chart.

For instance, the 92°30'W meridian, midway between the 92°W and the 93°W meridians, is marked off into minutes of latitude

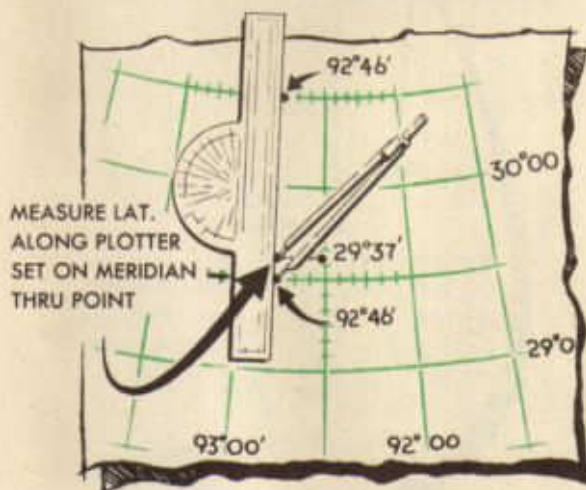

and the 29°30'N parallel, midway between 29°N and 30°N, is marked into minutes of longitude. It is required to locate a point whose coordinates are 29°37'N-92°46'W. Find on the parallels marked 29°30'N and 30°30'N (or the top parallel on the chart), the point 92°46'W. This will be 16' to the left of the meridian marked 92°30'W. Measure, on any meridian (probably the one marked 92°30'W) with the dividers a distance of 7'. Then place the straight edge of the plotter across the points 92°46'W on the two parallels. Then any point on the straight edge is 92°46'W. To locate the point 29°37'N, 92°46'W, it is necessary to locate along the straight edge the point 29°37'N. This is done by measuring from the parallel marked 29°30'N with the dividers up the straight edge the distance of 7' previously measured.

Always draw in or indicate longitude with the straight edge of the plotter and measure latitude with the dividers. *Never reverse the procedure.* The straight edge should always be in a North-South position.

To read (or pick off) the coordinates of a given point, the procedure is about the same. Place the straight edge in a North-South position through the point whose coordinates are being sought, and through two parallels on which the minutes of longitude are marked. Shift the straight edge until the same reading is obtained on both parallels when the straight edge is exactly on the point. This reading represents the longitude of the point; e. g., 92°47'W. Then from a convenient parallel; e. g., 29°00'N, measure *up* along the straight edge with the dividers to the point. Then measure this distance in minutes along the nearest meridian which is divided into minutes; e. g., 92°30'W. Add the number of minutes measured on the dividers; e. g., 16', to the number of the parallel from which the measurement was taken by the dividers; e. g., 29°N, giving the latitude of the position; e. g., 29°16'N. The coordinates of the position thus obtained, then, are 29°16'N-92°47'W. Again it is cautioned to use the straight edge *only in the North-South position.*

In order to measure a course for flight of 500 nm. or less, the following steps should be observed:

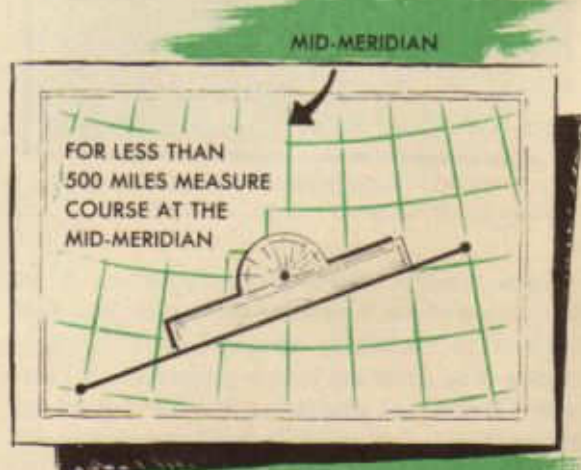

1. Locate departure and destination on the sectional and connect them with a straight line.

2. Select the mid-course meridian, the meridian nearest the middle of the course line.

3. Place a pair of dividers anywhere on the course line near the mid-course meridian.

4. Place the bottom edge of the plotter on the dividers. This facilitates lining up the plotter with the course line.

5. Slide the plotter along until the center hole is over the mid-course meridian.

6. Keeping in mind the direction of flight, read true course from the correct semicircle. A simple rule is to read courses on the semi-circular scale adjacent to the arrow that points in the direction of flight.

For flights of more than 500 NM., draw in the straight line joining departure and destination, divide the flight into parts (legs), each covering 4° or 5° of longitude, measure the course for each leg at the mid-meridian as directed above, and fly the flight one leg at a time, that is, changing course at the end of each leg. When this procedure is followed, the path of the plane differs very little from the straight-line course, and the difference may be ignored.

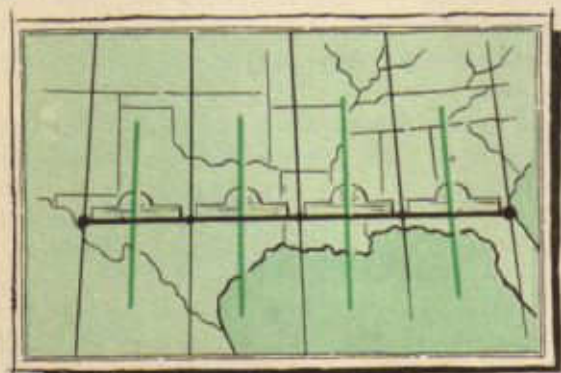

DIVIDE FLIGHTS MORE THAN 500 MILES INTO LEGS AND MEASURE EACH AT ITS MID-MERIDIAN

Occasionally course lines approach 0° or 180° ; therefore, a special technique has been devised to facilitate measurement of these angles. The diagram below represents a Lambert Conformal chart on which departure, destination, and course have been plotted. The course line is so nearly parallel to the meridians that it is impractical to extend it until it crosses a meridian before measuring; therefore, a special method must be employed.

The plotter is placed over the course in such a way that the center hole is over the course line and the upper edge coincides with the intersections of a parallel of latitude and the meridians on either side of the course. These intersections on the chart are named "A" or "B." An imaginary meridian can now be visualized on the chart by extending the 90° angle mark and the angle the course line makes with this imaginary meridian can be

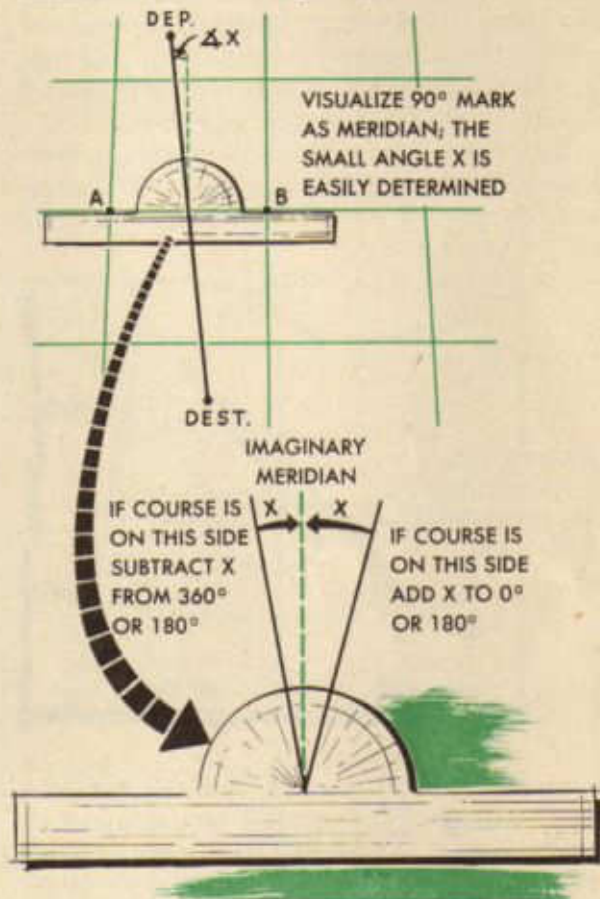

measured (angle X). Knowing this angle and the direction of flight, the true course can be found. For example, suppose angle X amounted to 5° and the direction of flight was southeasterly. Then the true course would be 180° minus 5° or 175° . By using the rule "right is plus and left is minus" the procedure may be somewhat simplified. If the course line is to the right of 90° on the plotter, angle X is added to 180° or 0° depending on whether the aircraft is going North or South. If the course line is to the left of 90° on the plotter, angle X is subtracted from 180° or 360° .

Some of the most common errors encountered in the manipulation of the plotter are:

1. Attempting to read a true course after placing the plotter along the course line in such a way that the semicircular part is lower than the bottom edge. Remember to keep the plotter on top of the course line.

2. Using the plotter as a protractor by placing the center over the course line rather than over a meridian. This procedure wastes time and results in numerous errors.

3. Failing to visualize direction of flight before reading the course angle. Constant reference to the arrows on the plotter will eliminate this error.

At various times it will be desired to plot a given course from a known position. In this case simply place a pencil point on the known position and slide the plotter back and forth across it until the center is on a meridian. Then from the desired course-angle marked on the semicircle, draw in the course line by moving the pencil along the lower edge of the plotter. It should be remembered that the meridian used must intersect approximately at the midpoint of the course line for accurate results; however, in this case rough estimation must suffice.

In measuring a course between two points it is well to remember a simple diagram. Around departure point (DP), imagine a circle, divided into four equal parts, beginning at North or 0° .

The first quarter (or quadrant) would be

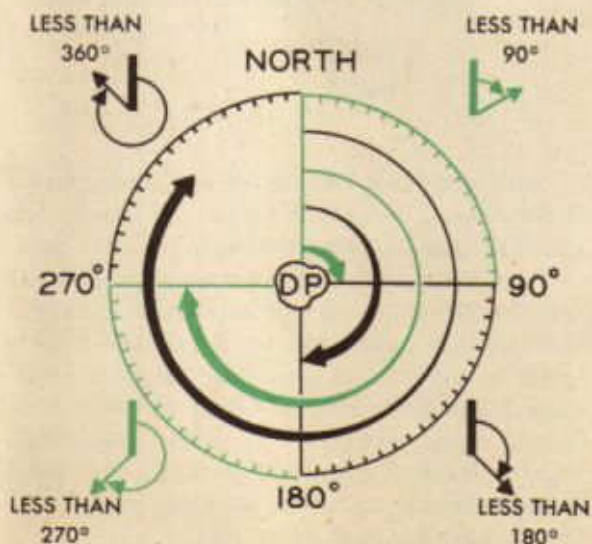

the 0° - 90° quadrant; the second, 90° - 180° ; the third, 180° - 270° ; the fourth, 270° - 0° . If the course line is in the first quadrant, the course angle cannot exceed 90° . If it is in the second quadrant, the angle must be between 90° and 180° . If the course line is in the third quadrant, the angle must be between 180° and 270° . Or if the course line is in the fourth quadrant, the course angle must be between 270° and 360° or 0° . Remembering this diagram, a person can glance at a course line, determine which quadrant it is in, and estimate the approximate course angle. This procedure will do much toward eliminating large mistakes in measuring the course, especially the mistake of 180° which results from reading the wrong scale on the plotter.

The problems of location and direction have been solved; therefore, distance must now be considered. The navigator is primarily concerned with nautical miles; hence sectional charts are graduated along meridians with this scale. If the distance between two points is desired, simply span the distance with a pair of dividers and use any convenient meridian which has the graduated scale to convert the distance into nautical miles.

Usually the length of the course lines to be measured will be greater than one span of the dividers. In such cases span a convenient distance, usually thirty nautical miles, with the dividers and step off the distance along the course. The remaining distance may be measured by adjusting the dividers and comparing with the scale. Thus, by multiplying the span distance by the number of steps and adding the remaining distance, the length of any course line can quickly and accurately be determined.

In the cramped quarters of the aircraft the use of dividers may at times be inconvenient. Under these circumstances time may be saved by using the plotter. Distance may be measured by using the bottom scale as a ruler. For short distances the vertical scales at each end of the plotter may be used profitably. However, it must be remembered that the use of dividers for measuring distances is more accurate; therefore, constant practice to insure proper and speedy use of this instrument will reward the industrious navigator.

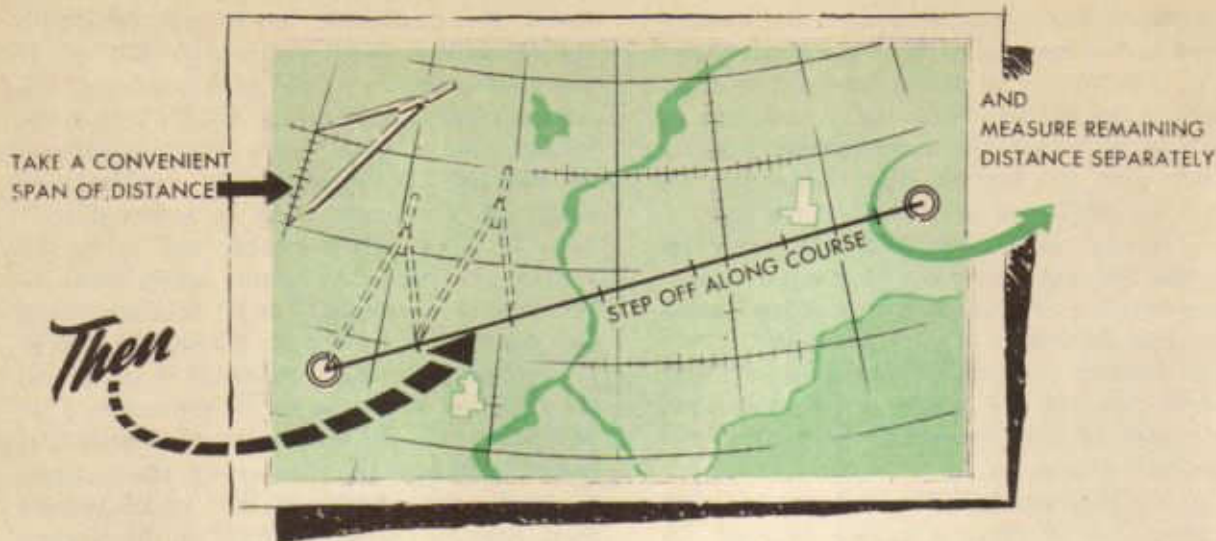

Some common mistakes which are made by the novice when learning to use dividers are:

1. Attempting to use both hands to manipulate the dividers. Dividers should be so adjusted that they can be operated with one hand. This leaves the other hand free for emergency use.

2. Leaving dividers open on the desk in an aircraft. Dividers should be closed and returned to a special pocket of the flight folder after use in order to avoid loss or injury.

3. Measuring distance along a parallel of latitude instead of a meridian.

4. Incorrectly counting the number of steps taken when measuring a long course, and failure to add the remaining distance after the last step.

5. Punching holes in sectional charts and thereby destroying property and causing inaccuracies. Dividers have sharp points for accurate measurement, not for punching holes.

At various times it will become necessary to parallel a line. This can be done by using the plotter or by using a combination of the plotter and the triangle.

To parallel a line with the plotter, align the parallel lines of the plotter with the original line, and at the desired distance from it mark a line along the straight edge. Or place center and 90 point of the plotter along the original line and then make dots on scales

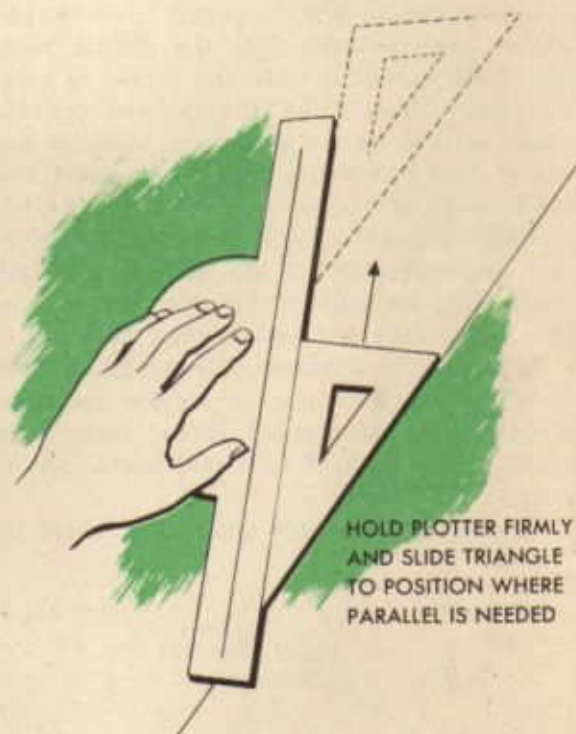

of both edges of plotter at the desired distance from the original line and draw the required parallel line through the two dots.

The most rapid and adaptable method for paralleling a line is accomplished by using both plotter and triangle. Align the hypotenuse of the triangle with the line to be paralleled. Place the straight edge of the plotter snugly along either of the other sides, then slip the triangle along the straight edge until the hypotenuse coincides with the position of the desired line and draw line.

TIME, SPEED, AND DISTANCE

Before further progress can be made in the study of navigation, it is necessary to get a clear understanding of time, speed, and distance. These terms are generally understood and the problems involving them require only elementary arithmetic for their solution.

Because of the ease with which they may be solved, there may be a tendency to consider these problems lightly. Such an attitude is very unwise. Problems of time, speed, and distance, although easily solved, are very important in navigation. A first class navigator must be able to solve them with great accuracy and rapidity. If a navigator can estimate within a few minutes the time of his arrival in the vicinity of a point, it will greatly facilitate his locating that point. Navigators have become completely lost because they were attempting to find points that were behind or ahead of the airplane.



The units of time with which the navigator works are the hour, minute and second with which he is already familiar. The unit of distance with which he usually works is

the nautical mile, which was explained in the discussion on the earth's surface as being the distance represented by one minute of latitude or 6,080 feet. In some cases, however, it will be necessary for the navigator to work with the statute mile (5,280 feet), or, when using foreign charts, he may work with the kilometer (3,281 feet).

Since the navigator may be required to work with three units of distance, the nautical mile, the statute mile, and the kilometer, he must be well acquainted with each of the units and must be able to convert, or to express any one of them in terms of the others. A previous discussion pointed out that in order to convert nautical miles into statute miles, multiply by 1.15. For instance, 10 nautical miles equals 10×1.15 or 11.5 statute miles. In the same discussion it was pointed out that in order to convert statute miles into nautical miles, divide by 1.15. Hence, 11.5 statute miles equal 11.5 divided by 1.15 nautical miles, or 10 nautical miles. These facts are true because a nautical mile of 6,080 feet is 1.15 times as long as a statute mile of 5,280 feet.

Since a nautical mile is 6,080 feet and a kilometer is only 3,281 feet, a nautical mile is 6,080 divided by 3,281 or 1.85 times as long as a kilometer. Therefore, to convert nautical miles to kilometers, multiply by 1.85. For instance 10 nautical miles equals 10×1.85 or 18.5 kilometers. To convert kilometers to nautical miles, divide by 1.85, 18.5 kilometers equals 18.5 divided by 1.85 or 10 nautical miles.

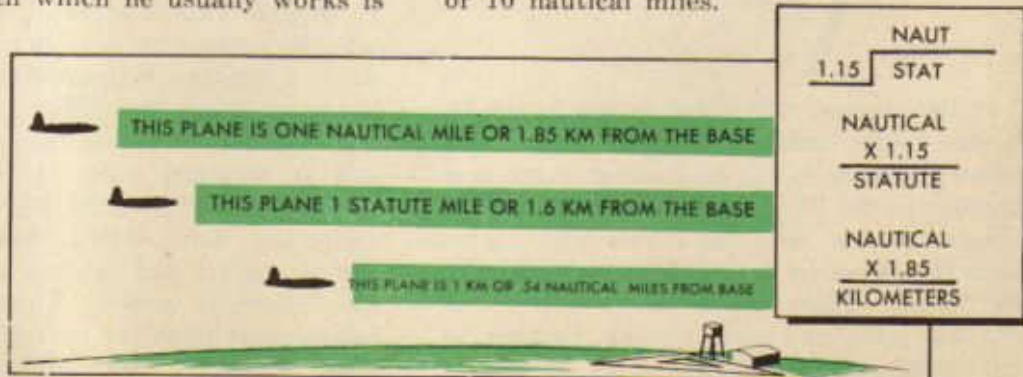

Fortunately, it is not necessary, usually, for the navigator to figure out these conversions, since he may find them on his computer almost automatically. However, he must know and remember how to figure them so that he may not be handicapped unduly when he has no computer.

Note the solid or metal side of the computer. This side of the computer is going to be used constantly; become thoroughly familiar with it. Note that there is a stationary scale and a revolving scale. At the top of the stationary scale is a "10" within a black block. Revolve the inner scale until the same kind of a block 10 is exactly under the one on the outer ring. Examination of the two scales from this position shows that they are exactly alike. Pay no attention at the present to anything except these two scales. The others will give trouble enough a little later. Notice that the division marks may be $\frac{1}{2}$ unit, as between 30 and 35; 1 unit, as between 10 and 11; or 2 units, as between 15 and 16. When using the computer, the student must exercise extreme care to read the scales correctly.

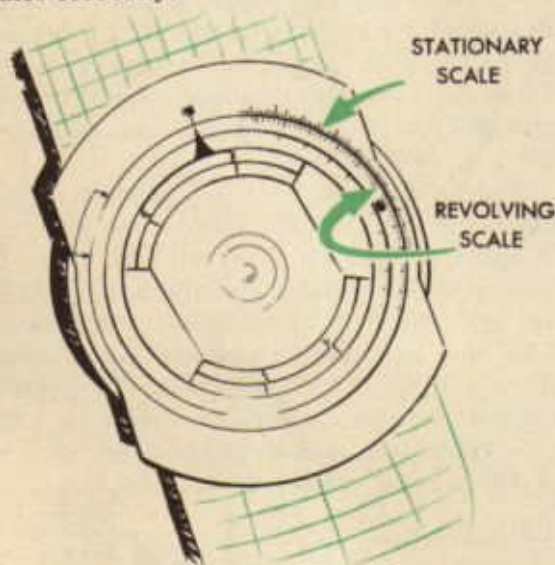

If the student will refer to the figure 70 on the outer scale, he will see near it an arrow pointing to the 66 division mark and another to the 76, joined together by a line across the top. Near the arrow pointing to 66 is the abbreviation, "Naut." and near the 76, "Stat." These abbreviations stand for nautical miles and statute miles. Further to the right on the stationary scale, at 122, is

another arrow with the abbreviation, "Km." standing for kilometer, written across the top.

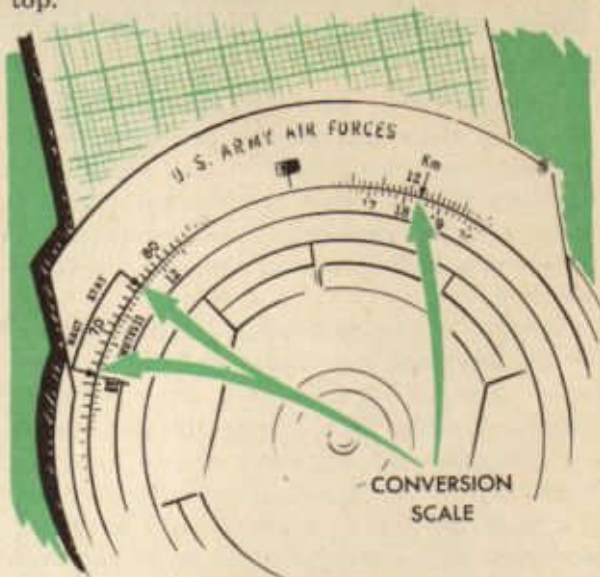

These three positions are thus marked on the computer because the computer scales are so constructed that when a number on the inner scale representing nautical miles is placed under the arrow with "Naut." above it, the number of statute miles in that number of nautical miles is read on the inner dial under the arrow with "Stat." across the top, and the number of kilometers is read under the arrow marked "Km." For proof of these statements, place the 10, representing 10 nautical miles, under the "Naut." arrow. The student already has seen that 10 nautical miles equals 11.5 statute miles or 18.5 kilometers. If the computer is correct, these figures should be under the proper arrows. Examination reveals, under the "Stat." arrow, the division mark half-way between 11 and 12, or 11.5 and, under the "Km." arrow, the mark half-way between 18 and 19, or 18.5. Thus it is seen that the computer gets the correct answer. It is seen, too, that when a number representing statute miles is placed under the "Stat." arrow, as 11.5 now is under the arrow, the number's equivalent in nautical miles is read under the "Naut." arrow and in kilometers is read under the "Km." arrow, that is, the equivalent in statute and nautical miles is read at the respective arrows. Thus, the computer will convert from one unit of distance to another accurately and rapidly.

Speed is expressed as units of distance per unit of time. The unit of time usually employed is the hour; the unit of distance may

may be found by multiplying speed by time, $150 \times 2\frac{1}{2}$, or 375 nautical miles. If the distance is 150 statute miles and the time is $1\frac{1}{2}$ hours, the speed is 150 divided by $1\frac{1}{2}$ or 100 miles per hour. If the distance is 200 kilometers and the speed is 150 kilometers per hour, the time is $1\frac{1}{3}$ hours.

These problems may be worked on the computer. Since problems of time, speed and distance are problems involving three and only three factors, the three factors must be located for every problem of this type. These problems are worked on the metal side of the computer which was discussed to some extent earlier. Distance is always located on the outer (stationary) scale, regardless of the unit of distance used.

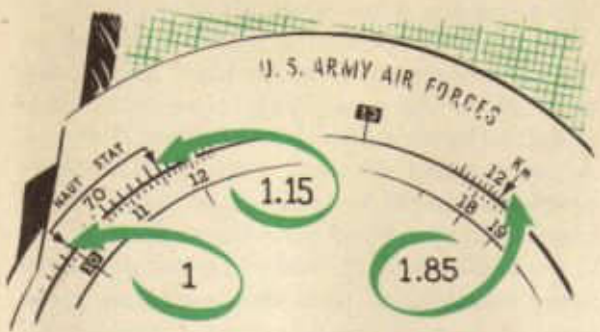

be either the nautical mile, the statute mile, or the kilometer. The phrase "nautical mile per hour" is the invariable expressed by the term, "knot." To speak of "knots per hour" is incorrect; the term, "knots" includes the "per hour" meaning. Other terms employed include "statute miles per hour" or more simply, "miles per hour" and "kilometers per hour."

Speed, as has been pointed out, is expressed as units of distance per unit of time. Since speed, then, is the result of a combination of time and distance, there must be some definite relation between time, speed and distance. Three very important relations are presented at the bottom of the page.

If any two of the three factors are known, the third or unknown factor may be found.

If the speed is 150 knots, the time $2\frac{1}{2}$ hours, the distance unknown, the distance

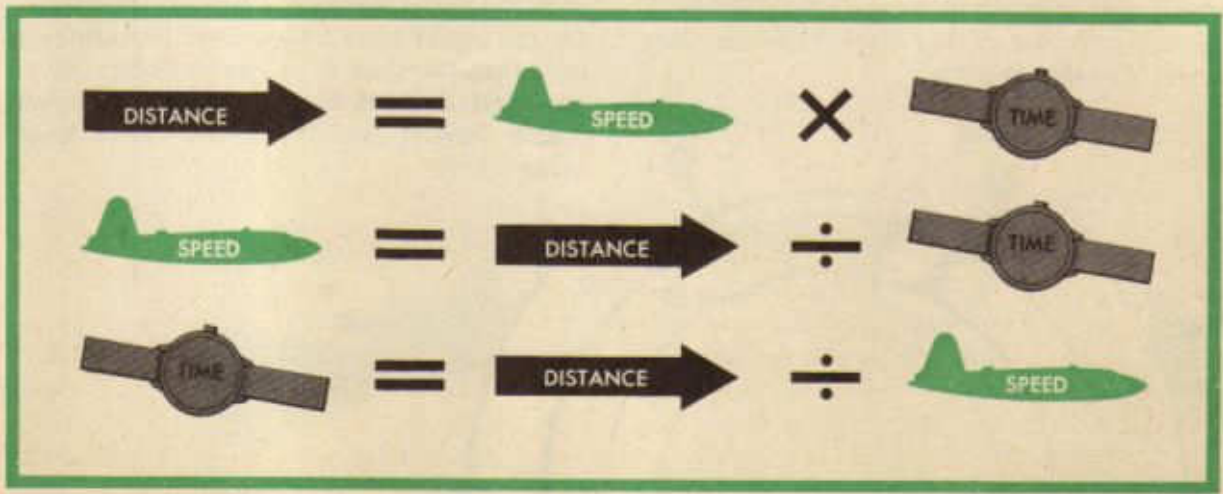
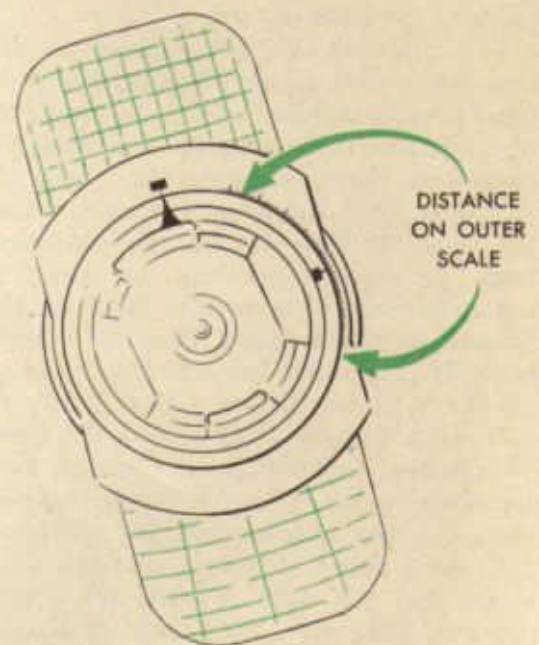

Time, in minutes, is located on the inner (revolving) scale. Once located, the point on the inner scale representing time in minutes is placed directly under the point on the outer scale representing distance. Speed is then read on the outer scale at the end of the black pointer on the revolving scale. This speed will be in the same units of distance per hour as was first set up on the outer scale. Following this procedure, any problem in time, speed, and distance can be worked through very accurately and rapidly. The two known factors are set up in their proper place and the third, then, is automatically shown. Remember that time and distance are always together, time on the inner and distance on the outer scale. Speed is always opposite the black pointer.

For purposes of illustration, some problems will be set up on the computer at this time. Given a distance of 20 miles and a time of 8 minutes, find the speed. The point 20 is located on the outer scale. The inner scale is rotated until the point 8 is exactly under the point 20. Opposite the black pointer is read 15, which represents the speed. But common sense dictates that 20 miles in 8 minutes is much faster than 15 miles per hour. The answer to the difficulty is to multiply the 15 by 10: the speed, then, is 150 mph.

Given a distance of 41 miles and a time of 15 minutes, find the speed. Place 15 on the inner dial under 41 on the outer dial; read the speed, 164 mph, opposite the arrow.

Given a speed of 156, a distance of 200 miles, find the time. Set the black arrow opposite 156, locate 200 (20) on the outer scale, and read time in minutes, 77, or 1 hour, 17 minutes (1:17) from the inner scale directly under the 20.

Given a speed of 216 mph and a time of 10 minutes, find the distance. Rotate the black arrow until it is opposite 216. Locate 10 minutes on the inner scale, read distance (36 miles) on the outer scale opposite the 10.

In all these problems, speed must be on the outer scale opposite the black arrow, distance is on the outer scale, time in minutes is on the inner scale, directly under distance. A great many of these time-speed-distance problems should be worked in order to develop both speed and accuracy.

In addition to the arithmetical and computer solutions of time-speed-distance problems, it may be necessary at times to use Time-Speed-Distance Tables, which are time-speed-distance problems worked out and printed in table form. Such a table is Table VII, "Speed-Time-Distance Table," page 182, TM 1-208, *Air Navigation Tables*.

It will be noted that across the top of the table is a number of blocks titled "Speed". Down the left side of the table is a column headed "Time in Minutes" and the remainder

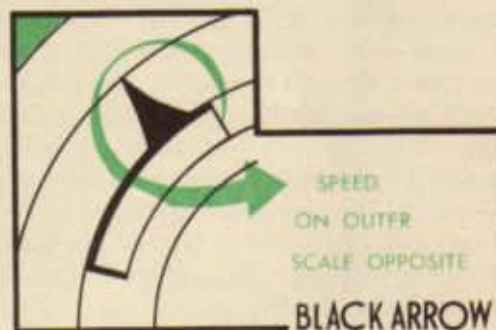

of the page is filled with columns lining up with the speed blocks and headed "Distance". On the top of page 183 is a similar table except that the time is in hours. Following on page 183 and 184 are two tables employing higher speeds for the minutes and hours table.

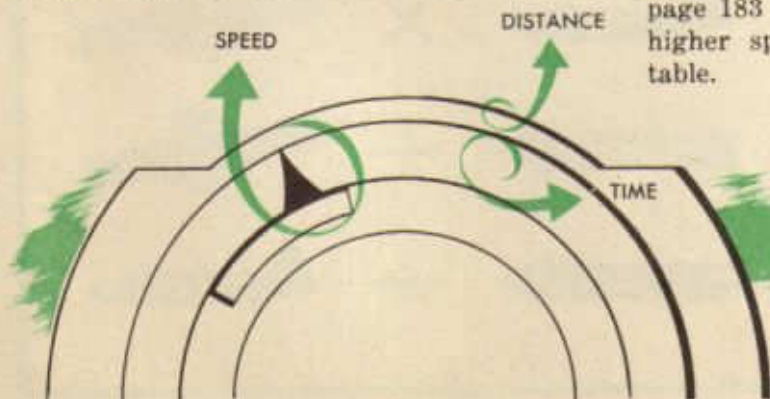

TIME, SPEED DISTANCE



TM 1-208

The use of these tables is simple. For example, how far will a plane go in 17 minutes at 120 knots? Look down the "Time in Minutes" column to 17; then follow across to the right to the "Distance" column that has the 120 "Speed" block above it. There is found 34, which is the answer to the problem. As another example, what speed is a plane making when it flies 46 NM in 21 minutes? Look down "Time in Minutes" column

to 21; then look to the right for 46 in the "Distance" column and look in the "Speed" block above the "Distance" column for the speed, 130 knots, in this case. In this problem, if the distance had been 44 NM, it would not have appeared in any "Distance" column, but would have been half-way between 42 and 46, both of which are shown.

If the distance were half-way between 42 and 46 the speed would be half-way between the speeds shown at the top of the 42 and 46 columns or half-way between 120 and 130, which is 125 kts.

The third example: how long will it take a plane to fly 72 miles at 140 miles per hour? Look down the column headed 140 until 72 is found; then look left to the "Time in Minutes" column for the answer, 31 minutes. In this problem if the distance had been 73, the time would be 31½ minutes, or 31^m 20^s. All these tables are used in the same manner and are not at all difficult to use or to understand.

DISTANCE BY
TM 1 208

ARMY AIR FORCES
TABLE VII
SPEED-TIME-DISTANCE TABLE

TM 1-208

Speed	70	80	90	100	110	120	130	140	150	160	170	180	190
1		1.2	1.3	1.5	1.7	1.8	2.0	2.2	2.3	2.5	2.7	2.8	3.0
2		2.3	2.7	3.0	3.3	3.7	4.0	4.3	4.7	5.0	5.3	5.7	6.0
3		3.5	4.0	4.5	5.0	5.5	6.0	6.5	7.0	7.5	8.0	8.5	9.0
4		4.7	5.3	6.0	6.7	7.3	8.0	8.7	9.3	10.0	10.7	11.3	12.0
5		5.8	6.7	7.5	8.3	9.2	10.0	10.8	11.7	12.5	13.3	14.2	15.0
6		7.0	8.0	9.0	10.0	11.0	12.0	13.0	14.0	15.0	16.0	17.0	18.0
7		8.2	9.3	10.5	11.7	12.8	14.0	15.2	16.3	17.5	18.7	19.8	21.0
8		9.3	10.7	12.0	13.3	14.6	16.0	17.3	18.7	20.0	21.3	22.7	24.0
9		10.5	12.0	13.5	15.0	16.4	18.0	19.5	21.0	22.5	24.0	25.5	27.0
10		11.7	13.3	15.0	16.7	18.3	20.0	21.7	23.3	25.0	26.7	28.3	30.0
11		13.0	14.7	16.5	18.3	20.0	22.0	24.0	26.0	28.0	29.9	31.8	33.7
12		14.3	16.1	18.0	20.0	22.0	24.0	26.0	28.0	30.0	32.0	34.0	36.0
13		15.6	17.5	19.5	21.5	23.5	25.5	27.5	29.5	31.5	33.5	35.5	37.5
14		16.9	18.9	21.0	23.0	25.0	27.0	29.0	31.0	33.0	35.0	37.0	39.0
15		18.2	20.3	22.5	24.5	26.5	28.5	30.5	32.5	34.5	36.5	38.5	40.5
16		19.5	21.7	24.0	26.0	28.0	30.0	32.0	34.0	36.0	38.0	40.0	42.0
17		20.8	23.1	25.5	27.5	29.5	31.5	33.5	35.5	37.5	39.5	41.5	43.5
18		22.1	24.5	27.0	29.0	31.0	33.0	35.0	37.0	39.0	41.0	43.0	45.0

TECHNIQUE

The preceding discussions have treated, among other things, the earth's surface, the Lambert conformal chart, and map reading. It is possible now, with the background of information gained in the preceding discussions, to consider no-instrument navigation or *basic dead-reckoning*, the oldest and one of the most important methods of navigation. Basic dead-reckoning must be checked; the simplest check is map-reading (visual reference to objects on the ground) or, in other words, looking at objects on the ground. Basic dead-reckoning, properly checked, may be used by itself or it may be used in connection with precision dead-reckoning. Every navigator must be able to do skillful and accurate basic dead-reckoning.



BASIC DEAD-RECKONING IS SIMPLEST AND OLDEST METHOD OF NAVIGATION

Basic dead-reckoning checked by map-reading, is the oldest, the simplest, and the easiest method of navigation, and when conditions permit its use, one of the surest. However, conditions of modern flight often make it impossible to do map-reading; therefore, it must be supplemented by other navigation techniques. Basic dead-reckoning was employed on a large scale first, possibly, by the Phoenicians on their early voyages around the Mediterranean Sea.

Motorists use a sort of basic dead-reckoning constantly over both known and unknown territory. Even in going from quar-

ters to town a motorist proceeds along a certain course (street) to a certain point which he recognizes by landmarks, turns onto another course, and repeats the procedure, arriving at destination in a few minutes.

When a motorist takes a trip of some length, he employs basic dead-reckoning to a great extent. From the filling station he gets his road-map (chart), locates his departure point and destination, calculates the distance, considers the possible routes and selects a

THE MOTORIST USES BASIC DEAD-RECKONING

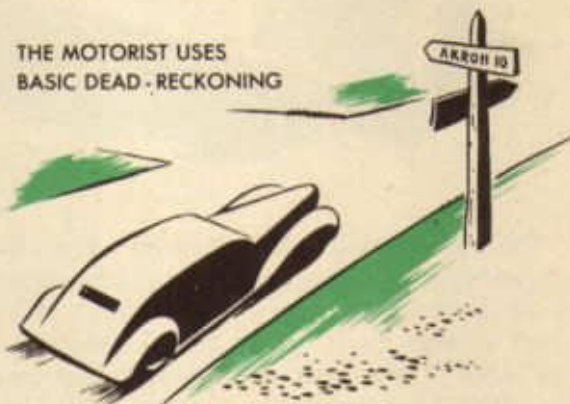

route suitable for the trip, and notes the points on the route that he is to pass through. When he is ready to begin his journey, the motorist will find his highway (course), proceed along the course to a certain town, turn onto another course, and repeat the procedure, finally arriving at destination.

During a motorist's journey he is assisted by sign posts, highway signs, and various other aids furnished to travelers. He can be certain of the name of a town along his route, because he will see the name on various sign posts, both before and as he reaches the town. He can keep track of his journey on his road-map and be fairly certain of his position at any time.

A navigator will proceed in exactly the manner described above. He will encounter many more difficulties than does the motorist, however. The navigator must make his own road-map on his chart before he begins his flight. He must be able to recognize points from the information on his chart; the names and distances are not printed on aerial signposts. The navigator must refer constantly both to his chart and to the ground. He must be alert.

The navigator must make considerable preparation before his flight begins. He must locate his departure point and his destination. He must draw in and measure the course line joining the two points. For a short flight between points on a single sectional, this is simple. For long flights, covering two or more sectionals, it is best to draw in and measure the course line on a smaller scale map such as a regional chart, ascertain the coordinates of points on the course that fall near the edges of the various sectionals covered, locate these points on the various sectionals, and draw in the course on each separate sectional. The course line should be

DRAW IN COURSE LINE
WITH A SOFT PENCIL.
DIVIDE COURSE INTO
10-MILE LEGS

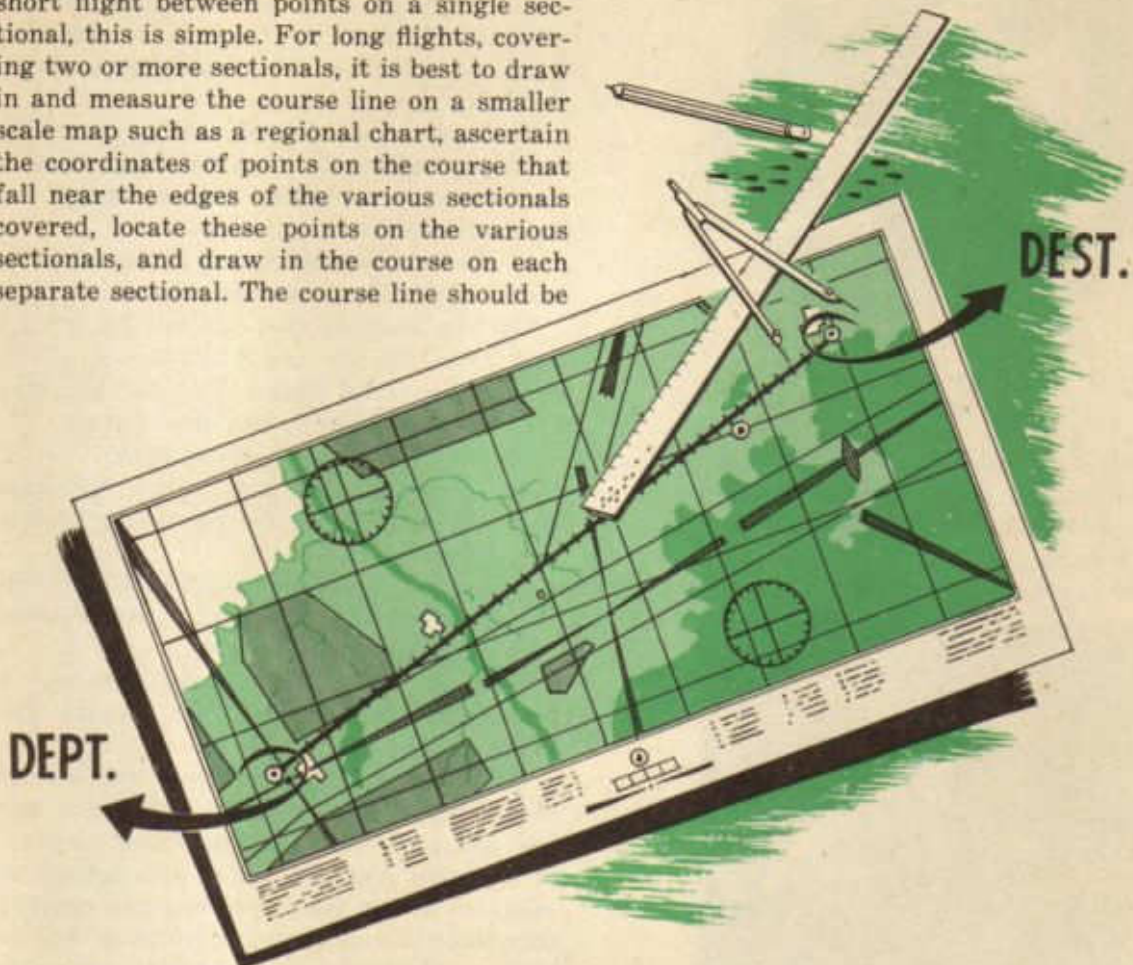

drawn in with a soft-lead pencil so that it will be plainly visible, even in poor light. The route then should be divided into 10-mile legs and the distance from departure to each division mark should be plainly marked. This procedure eliminates most of the work of measuring distance when the flight is under way.

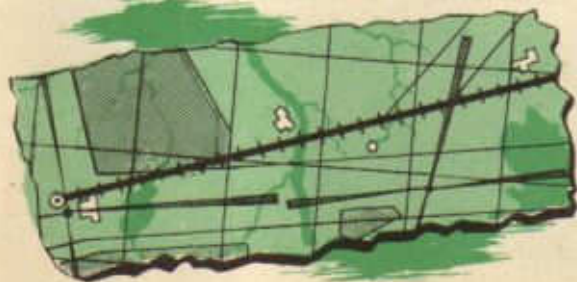

Having drawn in and measured the course, the navigator must study his chart very thoroughly so as to know as well as possible what to look for in the territory on and adjacent to the course. Since he may not be able to follow his course exactly, he must be acquainted with the territory for a considerable distance on either side of the course.

After becoming acquainted with the territory which the flight is to cover, the navigator will give particular attention to a number of *recognition points* which will serve as checking stations on the flight. The selection of these points is of great importance and will be discussed at some length in a moment.

Having finished his work on the chart, the navigator will fold and arrange his chart or

charts so as to be able to turn the folds like the pages in a book. In this way, his charts will remain neat and accessible and will not become misplaced, disarranged, or difficult to use.



FOLD MAP AND TURN FOLDS LIKE PAGES IN A BOOK

Mention has been made of the importance of the selection of proper and usable recognition points. Several suggestions may be in order because *the ground is not going to look like the chart*.



1. Much more is visible on the ground than on the sectional.

2. Many features prominent on the sectional are barely visible on the ground—radio stations, for example.

3. Water features are prominent both on the sectional and on the ground.

4. Highways and roads are prominent on the ground; railroads are relatively difficult to see.

5. Highways may be distinguished from railroads because they turn more often and more abruptly, and have roadside parks and the like.

6. Towns and villages must be recognized by their relation to other features; they, in themselves, are seldom distinguishable, one from the other.

7. There may be minor differences between the sectional and the ground.

On the basis of the contrast of what is seen from the air and what is seen on the sectional, several suggestions for the selection of recognition points are in order.

1. Look for water features first.

2. Look for cities and towns, highways, and railroads, noting the relation of each to the other.

3. Look for other distinguishable features, especially for water towers, prominent buildings, etc.

4. Look always for features that may be positively identified and that are the least likely to have been changed.

With these facts in mind, the student should select recognition points for at least one and preferably several flights as a sort of exercise. Arguments for and against the selection of any one point should be carefully weighed and considered. Why would the following points be good recognition points for a Kelly Field-Houston Airport flight?

1. Intersection of four roads before the Village of St. Hedwig.

2. Town of Seguin, with the dam, to the left of the course; crossing of long north-south stretch of highway.

3. The Village of Monthalia, noting water features and two dams.

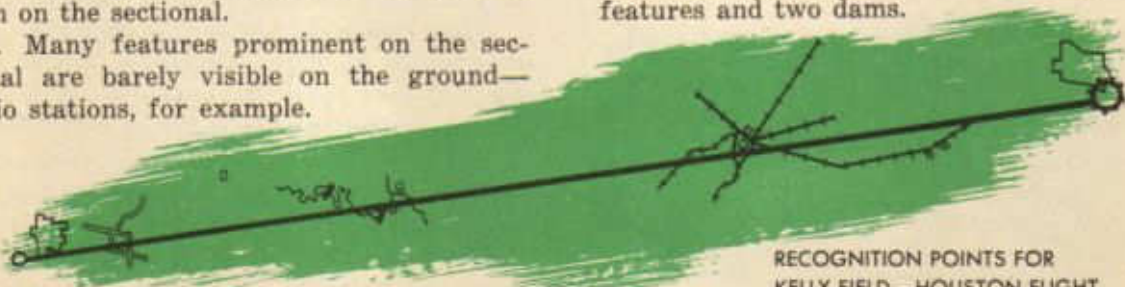

RECOGNITION POINTS FOR KELLY FIELD — HOUSTON FLIGHT

4. The city of Gonzales.
5. The city of Eagle Lake.
6. Richmond and Rosenburg in relation to position on course.
7. The prison farm and Sugarland.
8. Houston Airport.

Having prepared his chart and having selected his recognition points, the navigator has completed his pre-flight preparation and is ready for the flight. Upon taking his seat in the plane, the navigator should open the chart as if it were a book, exposing only the section showing the early stages of the flight. As the flight continues, he will turn the folds of the chart like pages in a book, keeping only a small portion exposed. It is well to place the chart, once the flight is underway, in such a position that north on the chart is toward true north. The chart then will appear very much as the territory over which the flight is taking place. Objects on the ground to the left of the course will be found on the chart to the left of the course and so on.

The navigator will be able to judge his distance on course by checking the time as he passes or comes abeam of the various recognition points. He can judge whether or not he is on course or how much he is off-course by checking the position of the plane with relation to points along or to either side of

the course. These and many other matters of this nature will be considered later in this discussion. For the present, the prime caution to a navigator doing basic dead-reckoning is "Keep Alert!"

At this point, three new factors must be considered, namely, groundspeed (GS), estimated time of arrival (ETA), and correction for off-course. Groundspeed is the speed which the plane makes with relation to the ground. Estimated time of arrival (ETA) is the time at which the navigator estimates he will arrive at a certain point. Correction for off-course is a change made in the heading (pointing) of the plane to take care of the plane's having gotten off the course in some way.

It has been suggested that the navigator might check his distance and position on course by basic dead-reckoning. This point becomes significant now. In the selection of the recognition points, the navigator will select certain of the best of these points to use for *check-points*. The check-points are very important, since at these points the navigator will make several checks and calculations upon which the success of the mission may depend. Because of their importance, the check-points should be very carefully selected. They should be not less than forty miles apart and must be easily recognized.

ORIENT MAP BY ALIGNING COURSE
LINE STRAIGHT AHEAD





AT THE CHECK-POINT, NOTE TIME AND DISTANCE FROM CHECK-POINT TO COMPUTE GROUND SPEED AND DISTANCE OFF COURSE

The first check a navigator makes upon coming over or abeam a check-point is on his time. In order to be of much use, this check must be very accurate. To insure accuracy, time should be checked when the aircraft is exactly over or abeam of the center of the check-point. Good navigators make a practice of sighting along the leading edge of the wing to the center of the check-point to determine when they are abeam. This is a good practice for the student to adopt.

The second check a navigator makes at a check-point is on the position of the aircraft in relation to the check-point. The aircraft may be over or to either side of the point. If to either side of the point, left or right, this fact is noted, and the distance left or right is calculated. The position of the aircraft can be judged and the position plotted on the chart. After its actual position is plotted, the actual position of the aircraft with relation to the course can be noted and, thus, it may be determined if, or how much, the plane is off-course, and when and how much to correct for off-course.

What use does the navigator make of the information gathered at the check-point? For one thing, he may calculate his ground speed. He has checked carefully the time of departure and the time he comes abeam of

the first check-point, forty miles or more away. From these two checked times he can determine the time it took for him to go the distance between the two points (departure point and check-point No. 1). This distance he can measure on his chart. So he has a time-speed-distance problem in which he knows time and distance and wants to find speed. He may solve this problem by formula or on his computer. He repeats this process at every check-point, that is, every forty miles or so, and thus keeps a constant check on his groundspeed between check-points.

Knowing his groundspeed, the navigator is able to calculate his ETA either to the next check-point or to destination. An accurate ETA is a great help to a navigator; an inaccurate ETA is a trap. An accurate ETA calculated as far in advance as possible enables the navigator to know when he may expect to sight his next check-point or his destination. Especially in unfavorable weather, when it is difficult to see recognition points along the way, this knowledge is of great value. He may be able to catch only a glimpse of the point through a rift in the undercast. If he is looking intently in the right direction at the correct time he will get this glimpse; otherwise, he may miss seeing the point altogether.

Figuring an ETA is another simple time-speed-distance problem. The navigator has found his groundspeed; he can measure on his chart the distance to the next check-point or to destination. The problem, then, is one in which speed and distance are known, and it is required to find the time. The problem may be solved by formula or by the computer. When the time is found, it may be added to the clock time at which the plane was abeam the preceding check-point and the clock time of arrival at the next check-point or at destination is found.

The navigator has checked the position of the aircraft with relation to the check-point and thus has been able to plot his position with relation to the course. This he has done in order to be able to hand the pilot a correction for off-course, which is known as *correcting for off-course* or *off-course correction*.

The procedure for correcting for off-course may be explained by illustrating a case. This is a greatly exaggerated case, but it will enable the student to understand the procedure.

A navigator departed from point A, going to point B, 110 miles away. Upon reaching check-point M, 50 nautical miles from A, the navigator finds that instead of being over point M, he is a distance which he estimates to be 10 nautical miles to the right of the position, at point X, and so is 10 miles off-course to the right. If he stays on the course which he is now flying, the navigator will go in the direction of the broken line XP and will not arrive at destination B. It seems evident that the course must be changed or corrected. This correction may be figured by table or on the computer.

To figure the correction by the table, the navigator refers to Table VI, "Off-Course Correction Table," page 181, TM 1-208, *Air Navigation Tables*. Notice that down the left side of the table is a column headed "Miles Flown". Across the top of the table is a series of boxes headed "Miles Off-Course", with columns for distances of from 1 to 50 miles. The navigator, in the problem under consideration, having flown 50 miles and being 10 miles off-course, looks down the "Miles Flown" column to the 50 line. This line he follows across the page until he reaches the column under the box with the 10 in it, where he reads 12° . He notes that at the top of these columns is a line "Compass Correction to Parallel Track Course." This means that if the navigator corrects his course AXP by 12° , he will parallel his intended course AMB. Such a course is represented by the line XN. It may be seen that this course, parallel to the intended course AMB, will not reach destination. Further correction must be made.

To make the further correction necessary to arrive at destination B, the navigator measures on the intended course line AB the distance yet to be flown, MB. This distance he finds to be 60 miles. The distance off-course is still 10 miles. The navigator again refers to Table VI, looking down the "Miles Flown" column until he reaches the 60 line, which he follows across the page until he reaches the column headed 10, where he reads 10° . This means that he must make a further correction of 10° in order to reach

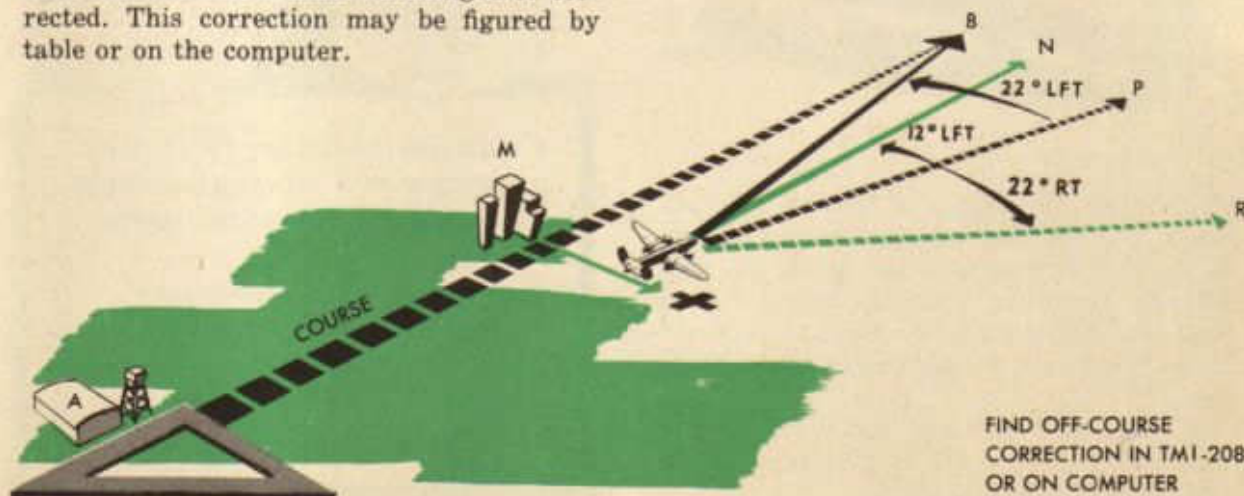

destination B. Therefore, since he must make a correction of 12° to parallel the intended course and a further correction of 10° to reach destination B, he must make a correction of 12° plus 10° or a total of 22° in order to reach destination B. Now the question is, in which direction must he make the correction, to the right or to the left? Referring to his charts, the navigator remembers that he now is on course AXP. If he makes the correction to the right he will be heading in the direction of R along the course XR, which obviously is not toward destination B. Therefore, he must make the correction to the left and follow along the line XB.

To figure the correction on the computer, the navigator must:

1. Place the card-board slide in his computer so that the square grid is under the transparent disk. This transparent disk may be in any position, but it must not be moved during the solution of the problem.
2. From the center circle, draw a line at right angle to the center line, and since the plane is off-course to the right, draw the line



to the right. The length of the line will represent the distance off-course, each square on the grid representing two miles. For this problem, therefore, the plane being 10 nautical miles off-course to the right, the line will cover five spaces to the right of the center line.

3. Turn the card over and place the distance from departure, in this problem 50 NM, under the center circle.

4. Read the number of degrees necessary to parallel course at the end of the line drawn, in this problem approximately 12° .

5. Place distance to destination, in this problem 60 NM, under the center circle and read degrees necessary to correct into destination, in this problem approximately 10° .

6. Add the two corrections, 12° to parallel plus 10° to converge, to get 22° total correction. Since the aircraft is off-course to the right, this correction must be made to the left. The total off-course correction is 22° left.

Having determined the amount and direction of the correction and having rounded off the correction to the nearest whole degree, the navigator is ready to hand the correction up to the pilot or to *hand up the correction*. This he does by writing on a piece of paper (a chit), "Correct course 22° left," and handing it up to the pilot or by calling on the interphone "Navigator to pilot—correct 22° left." Thus the navigator proceeds in correcting for distance off-course.

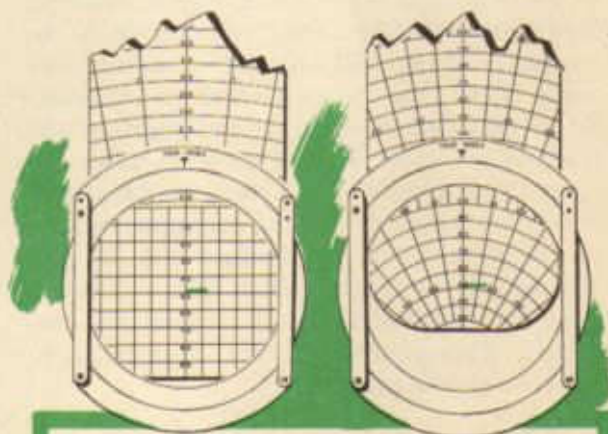

1. DRAW LINE FIVE SQUARES TO THE RIGHT
2. TURN CARD OVER. SET UP DISTANCE FROM DEPARTURE AND READ CORRECTION TO PARALLEL COURSE
3. SET UP DISTANCE TO DESTINATION AND READ CORRECTION INTO DESTINATION. ADD BOTH CORRECTIONS TO OBTAIN TOTAL OFF-COURSE CORRECTION

PROCEDURE

In order that the student may understand what a navigator does on a basic dead-reckoning mission and how the navigator completes the log sheet, he will imagine that he is accompanying and observing the navigator on a basic dead-reckoning flight from Love Field, Dallas, to the Big Spring Airport. The importance of the navigator's log sheet can hardly be over-emphasized; it may be judged from the fact that the *log* (as the log sheet is called) is admissible in a military court as evidence concerning the flight. It should be kept carefully at all times.

The actual form of the log sheet changes from time to time. In this discussion, there-



fore, general log procedure will be illustrated by working through the problem and recording the data on a simple log blank. The stu-

dent will have to study any log sheet he comes in contact with and see how, exactly, to enter the various items.

The *data* (facts) of the Love Field-Big Spring Airport flight is as follows:

This is a flight from Love Field (35°52'N-92°42'W) to Big Spring Airport (32°14'N-101°31'W). A current date is to be used. The type and number of the aircraft is B-25, N-54, A. C. No. 41-21192. It is a basic dead-reckoning mission. J. Doe, 1st Lt., A. C., is the pilot. The student's name is entered as navigator. The following flight data is to be used:

Proposed flight altitude, 6,000'
Altimeter setting, 30.24
1015, engines started
1025, take-off
1030, at flight altitude, 6,000', over Love Field
1049, 5 miles left of Weatherford
1108, 2 miles right of Ranger; calculate position with reference to course and correct for off-course
1129, 2 miles left of Abilene
1153, 4 miles left of Colorado
1207, over Big Spring

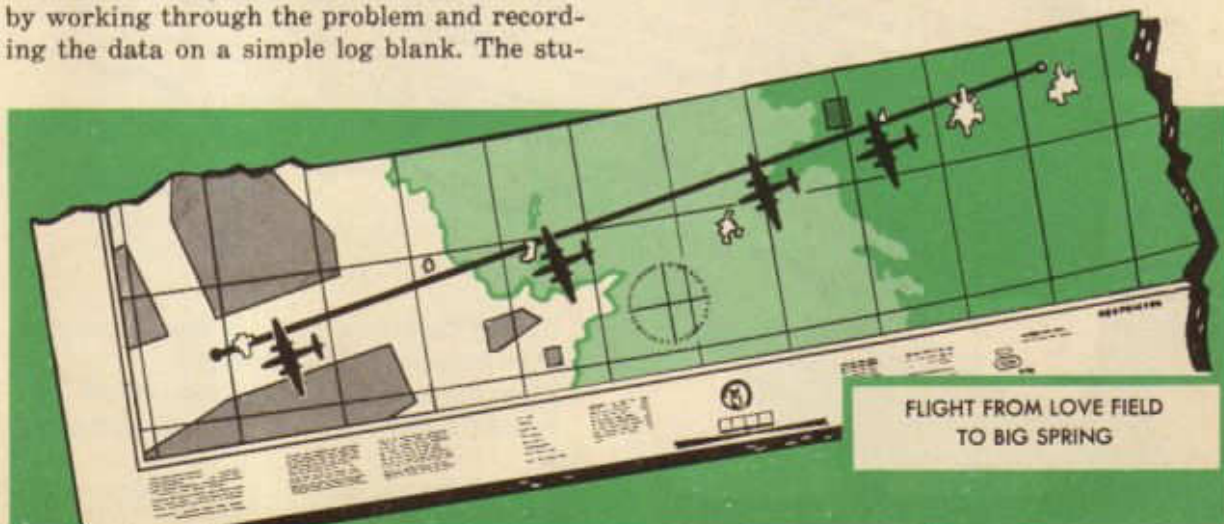

Before the flight begins, the navigator should check his plotting equipment to be sure he has all the equipment he needs. He should not neglect to have *several* well sharpened pencils!

The first step is the preparation of the chart. Both Love Field and Big Spring Airport are on the Dallas Sectional, so the navigator uses only one chart.

The navigator locates departure point (Love Field) and destination (Big Spring Airport) and draws a straight line between them. This line represents the course, or the line desired to be flown. With the plotter, following the procedure already outlined to the student, the navigator measures the direction of the course at the mid-meridian and finds it to be 261. He notes that the variation about the middle of the flight is 10E. He measures the distance between departure and destination, finding it to be 238 nautical miles. Then he marks off the course into 10-mile legs. The navigator then selects a number of recognition points along and adjacent to the course line and of these points selects four check-points. Because they are good-sized towns, easily recognized and not likely to have been changed much, and because they are more than 40 miles apart, the navigator chooses for his check-points the towns of Weatherford, Ranger, Abilene, and Colorado.

This completes his work on the chart; therefore, he folds it properly and turns his attention to the log sheet.

The heading of the log sheet and a few other items the navigator can fill in before the flight actually is underway; to these he gives his attention. At this time he probably is in or about the aircraft, waiting to take off. On the line after the word "Departure" he enters the name and the coordinates of the departure point—Love Field (32°52'N-96°42'W), and after "Destination," the name and coordinates of the destination—Big Spring Airport (32°14'N-101°31'W). After the word "Date" he enters the current date and after "Pilot," the name, initials, rank, and branch of service of the pilot—Doe, J. B., 1st Lt., A. C. On the line after the words "Airplane Type and No." he enters the type, number, and Air Corps serial number of the aircraft—B-25, N-54, AC No. 41-21192. After "Navigator" he enters his own name, initials, rank, and branch of service as it usually is written. The number and type of mission he enters after the word "Mission"—No. 2, Basic Dead-reckoning.

NAVIGATOR'S LOG												REMARKS		
DEPARTURE	Love Field		32° 52' N	96° 42' W	PILOT	Doe J. B. 1st Lt. A.C.						Alt. Set 30.24		
DESTINATION	Big Spring		32° 14' N	101° 31' W	NAVIGATOR	James J. P. 1st Lt. A.C.						Prop. Alt. 6000		
DATE	4/5/43				MISSION NO.	2 Basic D.R.						Eng St. 1015		
PLANE NO.	B-25		N-54	AC 41-21192								Take off 1025		
POSITION	TIME	TRUE DRIFT	TRUE HEAD	VAR	MAG HEAD	DEV	COMP HEAD	TEMP C	ALT	GR OPEN	RUN TIME DIST	TO RUN TIME DIST	ETA	ETA DEST

ENTER PRE-FLIGHT INFORMATION PROPERLY

On the first four lines in the "Remarks" column he enters the following:
 First Line: Altimeter Setting—30.24
 Second Line: Proposed Flight Altitude—6,000'
 Third Line: Time of Engine Start—1015
 Fourth Line: Time of Take-off—1025

Most of the information entered so far the navigator has been able to get for himself. He may have had to ask the crew chief when the engines were started, or the pilot what the proposed flight altitude is. The pilot gets the altimeter setting from the control tower by radio and will give it to the navigator. The navigator must have all of this information and he will ask someone if he cannot find out the information for himself.



By this time the aircraft probably has taken off and is climbing to reach flight altitude. The navigator carefully notes the time of take-off and proceeds to fill in the first line of the body of the log sheet. In the position column he will note the position of the plane with relation to the departure point when departure point is reached, entering the name but not the coordinates of the point and in the time column he will enter the time. The true course, as measured on the Sectional, he enters in the true course column—261. On basic dead-reckoning mis-

sions, the navigator does not consider information usually entered in the "Drift Corr." column, so he marks through it. In the "True Head." column he enters the same number entered under "True Course"—261. Under the column headed "Var." he enters 10 E, the variation noted earlier on the chart. Since the variation is E, he subtracts 10 from the true heading and enters the result, 251, in the column headed "Mag. Head." The two following columns are not used in basic dead-reckoning. He will give the pilot the magnetic heading (251) before departure point is reached. When departure point is reached he enters *over Love Field* in the position column and the time, 1030, in the time column.

The navigator gives attention next to the double column headed "Run." In this column the navigator usually enters the distance run and the time taken to run the distance. Since, when the aircraft is over departure point, no distance has been run on course, the navigator marks across these columns. In the column headed "GS" (Groundspeed) the navigator usually enters the groundspeed, but when no distance has been run, no groundspeed can be determined, therefore the navigator marks across this column. The next column is a double column headed "To Run" and includes a column for recording distance remaining to be run and the estimated time to run this distance. In the distance to be run column, the navigator now enters the total distance to be run, which has been determined from the Sectional—238. Since no groundspeed has been calculated, no time can be entered in the time column. The next two columns are ETA columns, the first, headed

NAVIGATOR'S LOG													REMARKS				
DEPARTURE	Love Field			35° 53' N 96° 42' W	PILOT	Doc J.D. 1st Lt. d.S.							Alt. Set 20.04				
DESTINATION	Big Spring			33° 14' N 101° 31' W	NAVIGATOR	James J. P.							Alt. Alt. 6000				
DATE	4/1/43				MISSION NO.	# 2 Basic D.R.							Log. # 1015				
PLANE NO.	B-25 154			10-11-43									Take off 1025				
POSITION	TIME	TRUE COURSE	DRIFT	TRUE HEAD	VAR	MAG. HEAD	DEV	CORR. HEAD	TEMP. C	ALT	CR. SPEED	RUN TIME	DIST	TO RUN TIME	DIST	ETA	ETA DIST
Love Field	1030	041	-	261	10E	251	-	-	-	6000	-	-	-	-	238	-	-

"ETA," refers to ETA to next check-point and the second, headed "ETA to Destination" refers to ETA to final destination. The navigator now marks across both these columns, since no ETA can be calculated without a ground speed.

The navigator next enters the altitude—6,000', in the altitude column. The student will have had considerable instruction in altitude before actually going on a basic dead-reckoning mission; therefore, he need not



point. He notes carefully the relative positions of the town and the aircraft and when the aircraft is abeam the center of the town he checks his time and the position of the plane. The position of the aircraft—5 miles left of Weatherford—he enters in the position column, and the time—1049—in the time column. He moves to the right on the page along the second line to the run columns. In the distance run column, he enters the distance from Love Field to the position abeam Weatherford, measured along the course line on the Sectional—48 miles, and in the time column, the time it has taken to run from Love Field to the point abeam Weatherford—19 minutes. Using these figures, he works a time-speed-distance problem (knowing the distance, 48, and the time, 19; to find the speed) on the computer and finds the speed to be 152 knots, which figure he enters in the groundspeed column.

Passing to the "To Run" columns, the navigator draws a diagonal line from lower left to upper right across both the spaces, making places for four entries in these columns. He measures the distance from the position abeam Weatherford to a position abeam the

worry about this matter at present. The navigator makes his next entry in the remarks column, writing here the plane's position with relation to the course—on course over departure point at flight altitude.

The navigator presently notes that he is approaching Weatherford, his first check-

NAVIGATOR'S LOG												REMARKS					
DEPARTURE	Love Field			32° 25' N 96° 42' W		PILOT	Duc J. P. 1st Lt. A.C.					Alt. Set 2024					
DESTINATION	Big Spring			32° 14' N 101° 31' W		NAVIGATOR	James J. P. 1st Lt. A.C.					Ht. Alt. 6000					
DATE	4/5/43			AC # 41-21192		MISSION NO.	# 2 Basic D.R.					Eng. St. 1015					
PLANE NO.	B-25 N4					CR	SPD	RUN TIME	DIST	TO RUN TIME	DIST	ETA	ETA DEST				
POSITION	TIME	TRU CRSE	HEAVY	TRUE HEAV	VAR	MAG HEAV	DEV	COMP HEAV	TEMP °C	ALT	CR SPD	RUN TIME	DIST	TO RUN TIME	DIST	ETA	ETA DEST
Love Field	1030	341	-	341	102	351	-	-	-	6000	-	-	-	238	-	-	-
Weatherford	1049	341	-	341	102	351	-	-	-	6000	152	19	48	1107 1/2	1204	4 mi. left of base	

RUN TIME	DIST	TO RUN TIME	DIST	ETA	ETA DEST
-	-	-	238	-	-
19	48	152	48	1107 1/2	1204

next check-point, Ranger—47 miles, and writes it in above the diagonal line he has just drawn in the distance to run column. He then calculates on the computer the time necessary to run this 47 miles at the ground-speed of 152 knots and finds it to be 18½ minutes, which figure he enters above the diagonal line in the time to run column. He adds this 18½ minutes to the time noted when he was abeam Weatherford—1049, and finds that he should arrive at a point abeam Ranger at 1107½, which time he enters in the ETA column. He then turns his attention to filling out the spaces under the diagonal lines drawn in the "To Run" columns. First he takes the distance run on course between Love Field and Weatherford—48 miles, and subtracts it from the total distance to be run—238, and gets the distance remaining to be run—190 miles. This figure he enters under the diagonal line in the "Distance to Run" column. He then calculates, on the computer, the time required to run 190 miles at 152 knots, which he finds to be one hour and fifteen minutes, which time he enters below the diagonal line in the time to run column. This time he also adds to the time he was abeam Weatherford—1049, and gets the time he should be at destination—1204, which he enters in the "ETA to Dest." column.

The navigator passes now to the altitude column and makes a check mark (✓) indicating that the altitude is still 6,000'. He then plots, on his chart, a position abeam of Weatherford and 5 miles to the left of it,

which he finds to be 4 miles left of the course, so he enters this note—"4 miles left of course"—in the remarks column.

Having completed the log sheet requirements for the first check-point, the navigator turns his attention to picking up recognition points and looking out for the second check-point, Ranger. He knows that he should be abeam of Ranger about 1107½; a few minutes before that time, he begins to look for the town. Sighting the town, the navigator checks carefully the time and position as he did at the first check-point and enters the information on the third line of the log sheet, following the same procedure as he followed in the case of the first check-point. The position—2 miles right of Ranger—he enters in the position column and the time—1108—in the time column.

He passes along the third line to the "Run" columns and draws diagonal lines across the columns as he previously has done with other columns. Above the diagonal line in the "Distance Run" column he enters the distance between the check-points—47 miles—and the time it took to fly the distance between the check-points—19 minutes. Using these figures, 47 miles and 19 minutes, the navigator calculates a groundspeed—148½ knots—which he enters in the groundspeed column. To complete the distance run columns, the navigator adds the distance run on this leg—47 miles—to the total distance traveled before the beginning of the leg—48 miles—

2 Dumb 21 ~~~~~ July 14 1925

DATE	415143																
PLANE NO.	B-25	NSA No. 42192															
POSITION	TIME	TRUE CRSE	DRIFT	TRUE HEAD	VAR	MAG HEAD	DEV	COMP HEAD	TEMP C	ALT	GS SPEED	RUN TIME	DIST	TO RUN TIME	ETA	ETA DEST	REMARKS
Love Field	1030	261	-	261	10E	257	-	-	-	6000	152	18	48	1107	-	-	4 miles left of course
Weatherford	1049	261	-	261	10E	257	-	-	-	✓	148.5	19	47	1108	-	-	2 miles right of Ranger
Ranger	1108	261	-	261	10E	257	-	-	-	✓	148.5	19	47	1108	-	-	2 miles right of Ranger

Total Dist 95 miles
Total Time 38 min

to find the total distance run from departure point—95 miles—which figures he enters below the line in the distance run column. The navigator finds the total time elapsed from departure to the time abeam Ranger—38 minutes—and enters it below the line in the time run column. Having completed the run and groundspeed columns, the navigator fills in the distance run, time to run and

ETA to the next check-point—Abilene—and the total distance to run, total time to run, and ETA to Dest., Big Spring Airport, in the same way that he filled in that part of the log on line two. He checks his altitude in the altitude column.

The navigator plots the position 2 miles left of Ranger on his chart and notes that it is 8 miles left of the course. This information he notes in the remarks column. Noting that he was off course 4 miles left at the first check-point (Weatherford) and 8 miles left at the second check-point (Ranger), the navigator decides to correct for off-course, following the procedure outlined in the previous discussion. He knows that he has flown 95 miles, that he has 143 miles yet to fly, and that he is 8 miles off-course. Referring to Table VI, page 181, TM 1-208, the navigator finds that no 95 line is shown, so he uses the 90 line. Following that line to the 8 mile column, he finds that he must correct 5° to parallel the intended course. But he wants to do more than parallel the intended course; he wants to go into destination. Therefore, he enters the table again at the 140 line and in the 8 mile column he finds 3° . This 3° he adds to the 5° already found, making 8° . He could have figured this correction on his computer if he had desired. Reference to his chart convinces the navigator that this correction should be made to the right; therefore, he writes on a chit, "Correct course 8° right," and hands it up to the pilot. These same words he writes in his log sheet, in the

space on line three of the remarks column.

At Abilene and at Colorado the navigator makes observations and calculations of the same kind and in the same manner as at Ranger, except that it is not necessary to correct for off-course again. The information is recorded in the same manner as has been noted already.

At 1207 the navigator comes over the Big Spring Airport. This information he notes in the position and time columns. He notes the course— 261° —in the true course column. He makes the entries in the run columns in the same manner that he has been making them in the other lines. He calculates a groundspeed at this point, using the total distance—238—and the total time run—1:37. This groundspeed he finds to be 146 and he enters it in the groundspeed column. Since there is no distance remaining to be run, he marks across the "To Run," "ETA," and "ETA to Dest." columns. He writes the altitude—6,000'—in the altitude column. In the remarks column he writes the position of the plane with relation to the course and how much the time of arrival over or abeam of Big Spring Airport varies from the last ETA to Dest. Having done these things, the navigator "closes out" the log by drawing two heavy lines, close together, across the page, just under the last entry. Closing out the log completes the navigator's work for the flight.

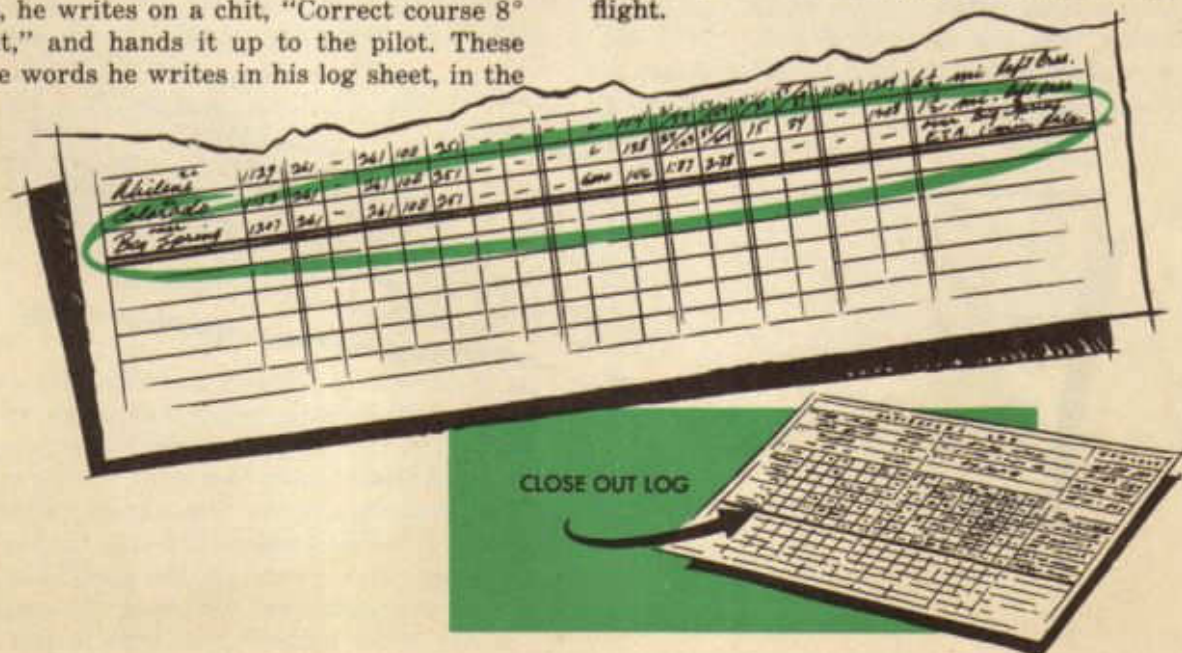

FLIGHT FROM LOVE FIELD TO BIG SPRING



- 1. CHECK FOR CORRECT DATA
- 2. CHECK FOR CORRECT DATA
- 3. CHECK FOR CORRECT DATA
- 4. CHECK FOR CORRECT DATA
- 5. CHECK FOR CORRECT DATA
- 6. CHECK FOR CORRECT DATA
- 7. CHECK FOR CORRECT DATA
- 8. CHECK FOR CORRECT DATA

NAVIGATOR'S LOG

DEPARTURE: Love Field
 DESTINATION: Big Spring
 DATE: 4/5/45
 PLANE NO.: B-25 HV
 PILOT: Du. J. B.
 NAVIGATOR: Du. J. B.
 MISSION NO.: 1st Lt. A. L. B. & 1st Lt. D. E.

POSITION	TIME	TRUE CRSS	DRIFT	TRUE HEAD	VAR	MAG HEAD	DEV	COMB HEAD	TEMP °C	ALT	GS SPEED	RUN TIME	DISP	TO RUN		ETA	ETA DEST	REMARKS
														TIME	DIST			
Love Field	1230	261	-	261	100	261	-	-	-	6000	-	-	-	-	-	-	-	1st Lt. A. L. B.
Weatherford	1249	261	-	261	100	261	-	-	-	6000	18	48	145	2.38	-	-	-	1st Lt. D. E.
Ranger	1248	261	-	261	100	261	-	-	-	6000	18	48	145	2.38	-	-	-	1st Lt. A. L. B.
Abilene	1257	261	-	261	100	261	-	-	-	6000	18	48	145	2.38	-	-	-	1st Lt. D. E.
Colorado	1257	261	-	261	100	261	-	-	-	6000	18	48	145	2.38	-	-	-	1st Lt. A. L. B.
Big Spring	1247	261	-	261	100	261	-	-	-	6000	18	48	145	2.38	-	-	-	1st Lt. D. E.



Precision Dead-Reckoning

OVERVIEW

I. BASIC IDEAS AND TOOLS OF PRECISION DEAD-RECKONING

A. Headings (horizontal position)

1. Basic ideas: direction, longitudinal axis, headings
2. The compass and the measurement of heading
3. Type of headings (true, magnetic, and compass) and their relationships

B. Altitude (vertical position)

1. The idea of altitude
2. Types of altitude (true, absolute, pressure)
3. The altimeter and the steps in the measurement of altitude

C. Airspeed and groundspeed

1. The ideas of airspeed and groundspeed
2. Instruments and steps in the measurement of airspeed

D. The effect of the wind

1. Basic ideas: course, track, drift, wind velocity
2. The driftmeter and the measurement of drift

II. CHARTS FOR PRECISION DEAD-RECKONING

- A. The Mercator plotting sheet
 - 1. Construction and limitations of the Mercator
 - 2. Use of plotting instruments on the Mercator
- B. The Lambert conformal and other charts for precision dead-reckoning

III. GENERAL TECHNIQUES EMPLOYED IN PRECISION DEAD-RECKONING

- A. Vector solutions
 - 1. General principles of vector solutions
 - 2. Triangle of velocities, a specialized vector problem
 - a. Composition of a triangle of velocities
 - b. Solution of a triangle of velocities, graphic and computer
- B. Keeping up with altitude
- C. Keeping up with heading, airspeed, and air position (keeping the airplot)
- D. Keeping up with the effect of the wind
 - 1. Finding the wind: multiple drift, double drift
 - 2. Using the wind
- E. Keeping up with track, groundspeed, and ground position (keeping the ground plot)
- F. Using the airplot and the ground plot for ETA's, etc.

IV. PRECISION DEAD-RECKONING PROCEDURE

- A. Chart work: airplot, ground plot, combinations
- B. The log

V. SPECIALIZED TECHNIQUES IN PRECISION DEAD-RECKONING

- A. Determination of instrument and installation error
 - 1. Driftmeter alignment
 - 2. Airspeed meter calibration
 - 3. Compass swinging and compensation
- B. Groundspeed by timing
- C. Controlled groundspeed
- D. Fuel consumption charts
- E. Great circle routes
- F. Patrol and search
- G. Interception
- H. Radius of action to same or alternate base

HORIZONTAL POSITION

Almost everyone at some time or other has had occasion to observe the uncanny sense of direction seemingly possessed by certain insects, birds, and animals. Wild bees, working a considerable distance from their hive, may be caught, placed in a bottle with flour, shaken around, and released. Immediately they head straight for the hive, leading the hunter to it. Cats may be carried many miles from home and every effort may be made to lose them, but their sense of direction is so unailing that "the cat came back" is the familiar refrain which ends every recital of such experiences. Wild birds fly unerringly for great distances, arriving year after year at the same feeding grounds.

But man does not have such a sense of direction. He becomes lost easily; he tends to travel in widening circles when he has no means of determining direction. In the air, he has not even a sense of up and down. Man must rely, therefore, upon his ingenuity to provide himself with instruments which will, in turn, provide him with a knowledge of direction.

As has been explained earlier, direction is measured in terms of angular distance from north, *clockwise*, through 360°. Two examples, below, may enable the student to recall other examples:

In example A, the direction indicated by

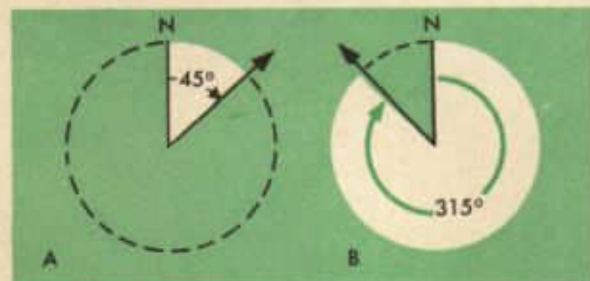

the arrow is $\frac{1}{8}$ of a circle or 45°. In example B, the direction indicated by the arrow is $\frac{7}{8}$ of a circle or 315°, since direction always is measured clockwise from north.

An important term used frequently in connection with direction is the *longitudinal axis* of the aircraft. The longitudinal axis of an aircraft is an imaginary straight line drawn through the exact center of the nose and tail of the aircraft, such as is represented in the figure below.

Another fundamental concept in this con-



nection is *heading*. Heading may be thought of as the direction in which an aircraft is pointing and is expressed in *terms* of the direction in which it is pointing. This direction is measured by measuring the angular distance from north, clockwise, to the longitudinal axis of the plane, such as the heading of 67° represented below:



Several instruments have been devised for measuring the angular distance from north to the longitudinal axis of the aircraft, or for measuring the heading of the aircraft. The most common of these instruments is the *magnetic compass*.

But before he can gain a working knowledge of the magnetic compass and its limitations, the student should have some background in magnetism and related subjects. He should not feel that he will be unable to understand it unless he has had high school or college physics, because the discussions of magnetism in this course are based upon the assumption that the student has had no previous training in the subject.

Almost everyone is acquainted with the fact that a magnet will attract iron nails and certain other metal objects and that this attraction is greatest at the ends or *poles* of the magnet. Not all metals are attracted to a magnet, but those which are attracted are called the *magnetic metals*, including iron, cobalt, nickel, and certain alloys. It is with these magnetic metals that the navigator is concerned.

For the purpose of simplifying their work in this subject, navigators have adopted a color scheme for naming the poles of a magnet. Without trying to label the poles as North or South, they give them the colors *red* and *blue*. An ordinary bar magnet may be represented as follows:

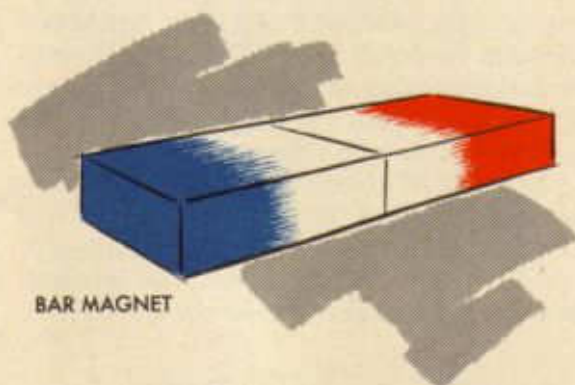

BAR MAGNET

Around every magnet there is a magnetic field. It is this field which causes an iron nail to be drawn toward the magnet. The magnetic field is composed of lines of force. These lines of force are invisible lines which may be likened to elastic bands. If lines repre-

senting the lines of force around an ordinary bar magnet are drawn, they appear something like the figure below:

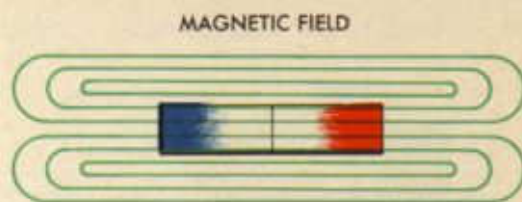

Since the drawing shows only two dimensions, the student should bear in mind that these lines of force lie in three dimensions and completely surround the magnet. These lines of force have certain characteristics, which, if thoroughly understood, will help to explain the properties of magnets.

The first property of these lines of force is that they are traveling in unbroken lines. The direction of travel is always from the red pole to the blue pole. In other words, they are always leaving the red pole and entering the blue pole. The path and direction of the lines of force may be represented as follows:

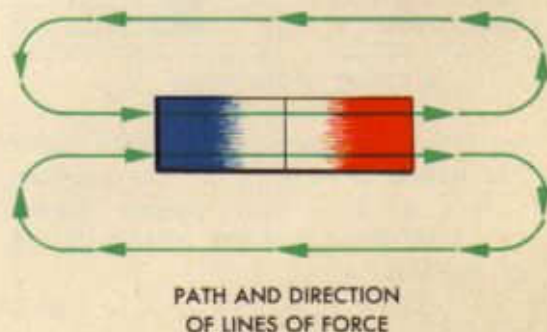

PATH AND DIRECTION OF LINES OF FORCE

The direction of the lines of force of a given magnet must be known, of course, before its poles can be labeled (painted) red and blue.

These lines of force have a second characteristic concerning their path; they may be likened to the little boy who walked two miles to get his pony in order that he might ride over to his neighbor who lived but one mile

away. In like manner, the lines of force of a magnet will stretch themselves out of shape in order to travel through a piece of magnetic metal. This characteristic can be shown by drawing a magnet with a metal bar near it and drawing in the lines of force as they

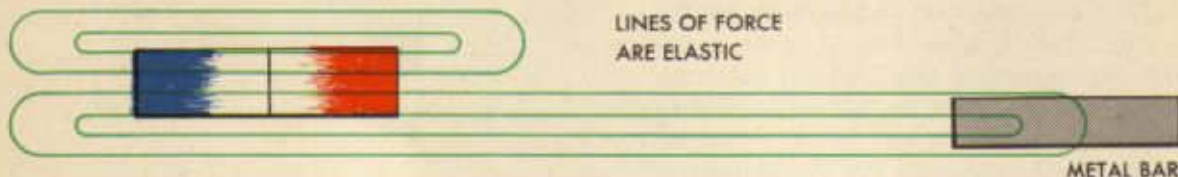

are stretched in order to pass through the metal.

It has been explained that these lines of force are elastic, and since they are elastic and tend to shorten themselves, they will try to draw the metal to the magnet. This is an explanation of the attraction of the metal to the magnet.

Nearly everyone has heard that like poles repel and unlike poles attract each other. This may be explained by the concept of lines of force. If two bar magnets could be placed so far apart that their fields or lines of force would not meet, they might be represented thus:



MAGNETS WHOSE FIELDS DO NOT MEET

Now if these magnets are brought closer together with like poles facing one another, their lines of force will oppose (press against) each other and the picture would appear like this:

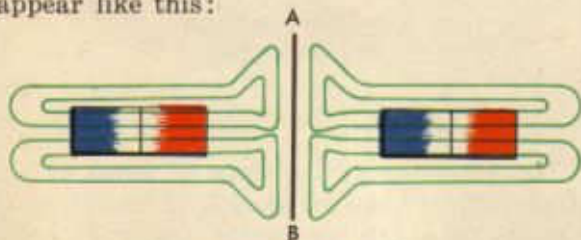

LIKE POLES REPEL

The vertical line AB is drawn to call attention to the fact that the lines of force do not cross or mingle with one another. They are compressed and cannot travel their normal

path because they would collide with the lines of force from the other magnet. Since these lines of force are elastic and tend to follow their normal path in spite of interference, they will exert a pushing force on each magnet which will cause each to be *repelled* by the other. This is an explanation for the rule that like poles repel.

If the magnets had been placed so that their lines of force were traveling in the same direction, they would present this picture:



UNLIKE POLES ATTRACT

Now the lines of force are combining and traveling through both magnets. Since these lines of force are elastic and must now travel a greater distance, they will tend to shorten themselves, and in so doing, will exert a force of attraction. Thus the two *unlike* poles will be attracted to each other.

The effect of placing two like and two unlike poles together has been shown. What is the effect upon a freely suspended magnet if it is placed in a large magnetic field in which the lines of force are flowing thus:

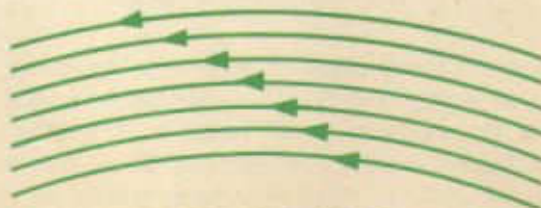

LARGE MAGNETIC FIELD

Imagine a bar magnet, suspended by a string, in this field. Try it first with the bar magnet at right angles to the flow of the lines of force. The lines of force in the large magnetic field will distort themselves to go through the suspended magnet, resulting momentarily in the condition pictured below:

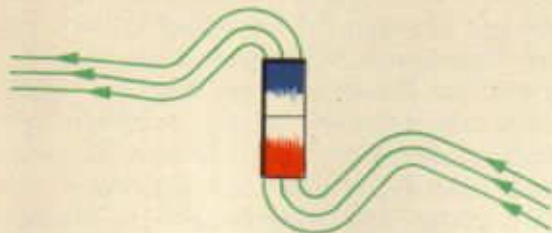

Note that the lines of force are now bent considerably in order to travel through the magnet from blue to red pole. Since these lines of force are elastic and tend to shorten themselves, they will exert a turning force on the suspended magnet and cause it to line up with the lines of force of the large magnetic field. The picture very soon would look thus:



Now regardless of what initial position the suspended magnet is given, the lines of force of the larger magnetic field will cause the suspended magnet to swing until it is aligned with the lines of force of the large magnetic field and always with the direction being such that the lines of force enter the blue pole and leave the red pole.

Consider the effect on a suspended magnet if a second magnetic field deflects the lines of force of the main field. If an immovable magnet is placed at right angles to the large field, the results will appear as below:

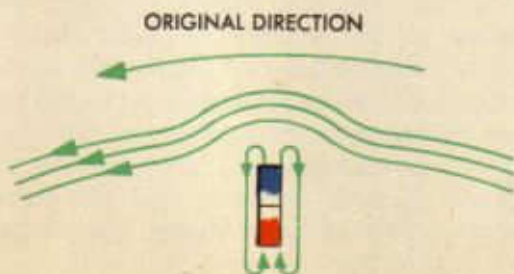

Now the lines of force are bulged upward and away from the red pole and if the suspended magnet is placed now in the large magnetic field its final position would be like this:

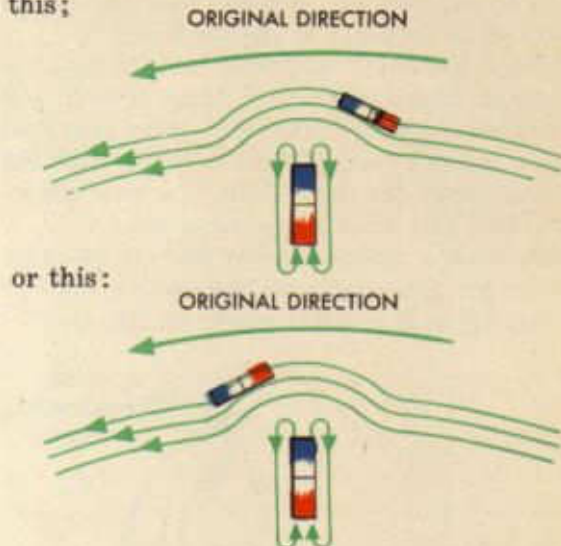

depending upon where it is introduced.

The main importance of these drawings is to show how a second fixed magnetic field will so deflect the first field as to cause a suspended magnet to point in a direction that does not represent the general direction of the travel of the lines of force of the original large magnetic field.

Up to this point, nothing has been said about the earth's magnetism. The earth may be regarded as a large magnet with its two poles located at points which *do not coincide* with the earth's geographic poles. The magnetic poles are not sharply defined. Navigators, in assigning colors to the poles, call the north magnetic pole the *blue* pole and the south magnetic pole the *red* pole. Then, drawing in the lines of force, the earth's field might appear like this:

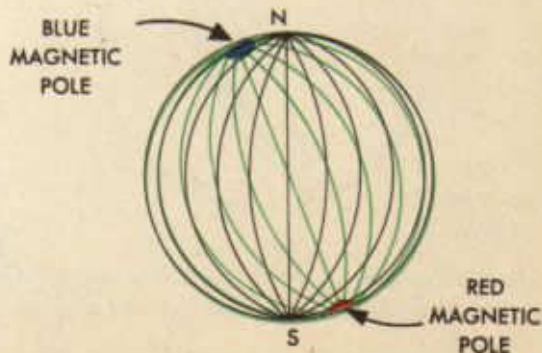

The terrestrial lines of force are represented by green lines; the geographic meridians, by black lines. It should be noted here that the green lines represent only the general direction of the lines of force and that not all the lines of force begin or end at a pole.

Since the south magnetic pole is red, the lines of force will travel from it and will enter the blue or north pole. Note also that these lines of force *do not coincide* with the meridians of the earth. This is a very important fact and must be remembered.

Suppose a suspended bar magnet is introduced at right angles to the earth's lines of force. Its first position might be like this:

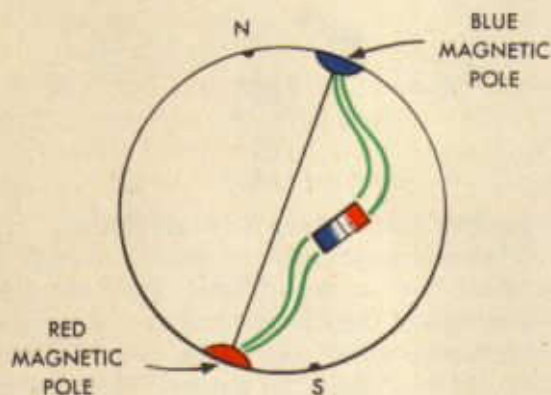

As has been seen already, the suspended magnet will be turned by the lines of force until finally it is parallel to the lines of force of the earth. Since the lines of force are leaving the red pole, the magnet will be turned so that its red pole is facing the blue pole or the earth's north magnetic pole as is represented in the diagram below.

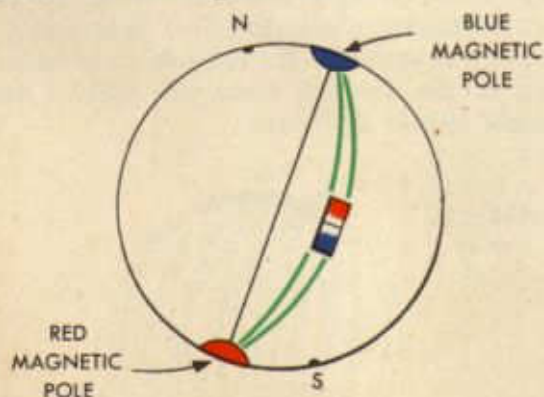

Note also that it is not pointing toward the earth's geographic pole, but toward the magnetic pole.

At this point it is well to point out that a magnet suspended in a large magnetic field will line up with the lines of force of the larger field not only horizontally (from side to side), but also vertically (up and down). The fact that the suspended magnet lines up vertically explains the action of the magnet which is called *dip or declination*, that is, the red end of a magnet suspended in the northern hemisphere will dip or come to rest at a position lower than the blue end. Conditions are reversed in the southern hemisphere, where the blue pole dips. The dip is least near the equator, approaching 0° over the equator, and greatest near the magnetic poles, approaching 90° over the poles. The fact of dip is of great importance in the polar regions, of little importance in the torrid and temperate zones.

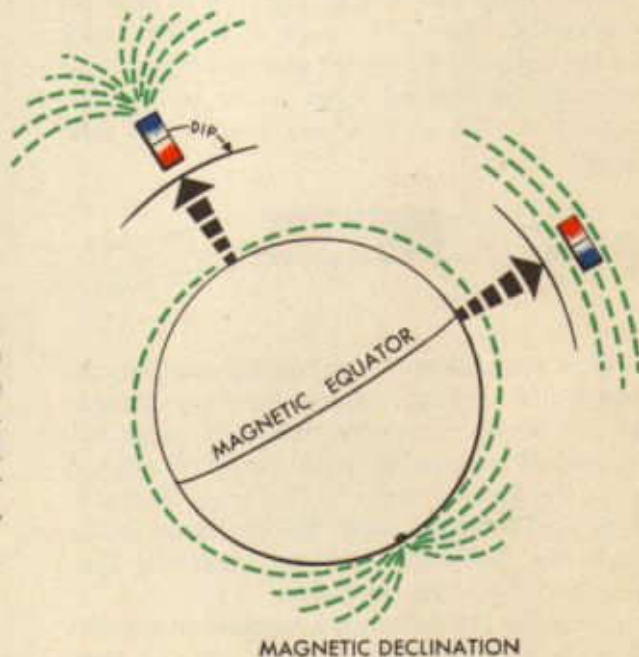

Earlier it was pointed out that a small magnetic field could deflect the lines of force of a larger magnetic field near or surrounding it. This fact is of significance now with relation to the earth's magnetic lines of force. At many places on the earth's surface there are deposits of magnetic materials that exert influence on the earth's magnetic lines of force. So numerous are these deposits and so great is their influence that the earth's magnetic lines of force do not run straight from pole to pole.

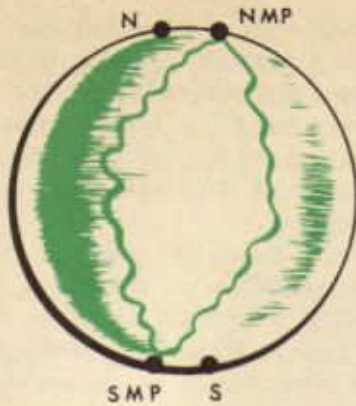

Typical lines of force probably actually appear as represented above. This means that a magnet, when lined up with such lines of force, will not point toward the magnetic north pole.

The fact that a small magnetic field will influence the effect of the earth's magnetic lines of force is of further significance to navigators because of the fact that there are present in the aircraft numerous small magnetic fields. All of these small fields in the aircraft, found in radios, motors, magnetic metals, etc., disturb the effect of the earth's magnetic lines of force in and about the aircraft. The discussion of the compass, which follows, will develop more fully the significance of these facts.

In the discussion of magnetism, an experiment was described that now should be performed. Tie a piece of untwisted tow string

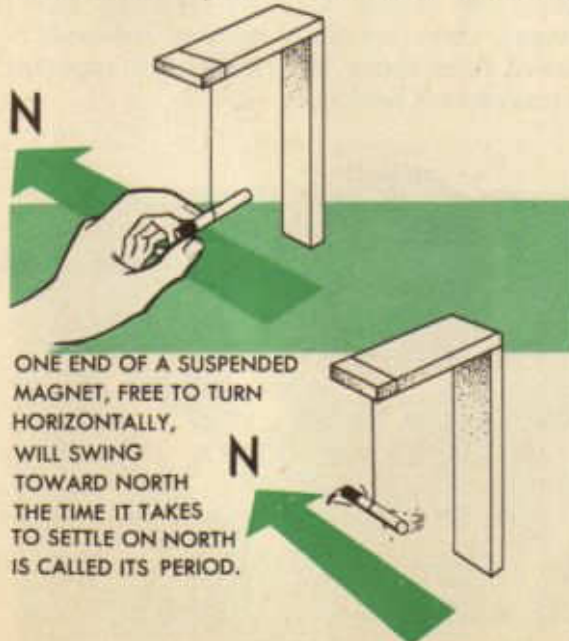

in the middle of a small bar magnet whose polarity is known and whose ends are painted, one red and the other, blue, to indicate the polarity. Observe what happens when this magnet is suspended from a bracket so that it is free to turn. The magnet turns until the red end points toward the north, regardless of where it is placed. Such an arrangement, consisting of a magnet free to turn horizontally, is the simplest form of the magnetic compass. Note that when the magnet turns to the north it overshoots and goes past north, stops, comes back, overshoots again, and repeats the process, finally coming to rest. The length of time consumed by this movement of the magnet from side to side before settling on north is called the magnet's "period."

Another very simple compass may be made by floating the magnet on the surface of some sort of liquid. Two or three small magnets may be mounted on a piece of sheet cork cut to fit loosely inside a glass tumbler. Care must be taken when mounting the magnets on the cork to point the like poles of the magnets the same direction and to mount the magnets parallel to one another. The cork, with the magnets mounted, is floated on top of the water in a half-filled tumbler. The magnets behave exactly as did the suspended magnet; the cork sheet swings around in its period, finally coming to rest with the red ends pointing north. The arrangement is a compass. From the construction of these two very simple compasses, it may be seen that the essential element of a compass is a mag-



netized needle whose polarity is indicated, suspended so as to be free to rotate horizontally.

The navigator will need, in addition to the needle pointing north, some means of determining the heading of his plane and some method of measuring the angular distance between the needle and the heading of the plane. If he has these two things, he can determine the direction the plane is heading. Therefore, in discussing a compass, it is well to consider the magnetic needle itself, the method of suspending the needle, the method of indicating the plane's heading, and the means for measuring the angle between the needle and the heading. These items will be discussed in order.

The army navigator's compass is the army Type D compass and is known as an *aperiodic* compass. It is called "aperiodic" because it is without a period; the needle swings to the north and stops there without swinging from side to side. The Type D compass is somewhat like the simple compass discussed earlier in which the needle was floated on water.

The magnetized needle of the Type D compass is not a single needle, but is a group of several small magnetized tungsten steel-alloy needles mounted on a card somewhat in the manner the needles were mounted on the cork sheet in the experiment described above. Attached to this card is a float, and in the middle of the card is attached a hard, iridium or agate-pointed pivot. The arrangement may be represented somewhat as below:

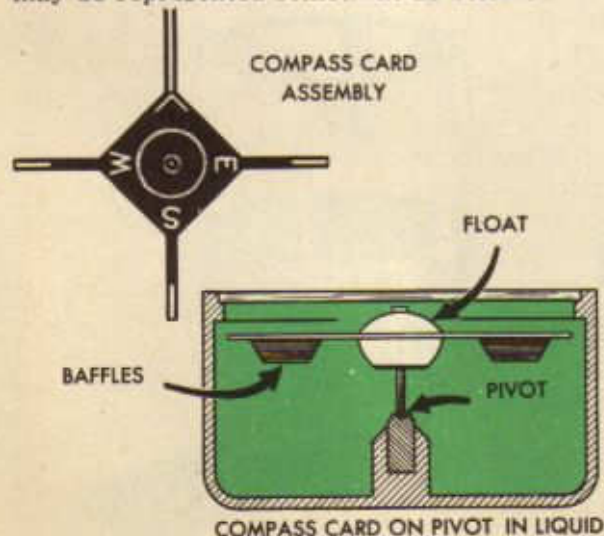

The pivot, with needle-card on top, is mounted on a sapphire bearing in the bottom of a non-magnetic metal cup, the needle-card assembly being free to turn horizontally in any direction. On the bottom of the needle-card are baffles or fins whose function will be explained now.

It has been mentioned that the Type D compass is aperiodic or without a period. This condition is brought about by "damping." The cup in which the needle-card is mounted is filled with a liquid, usually pure white kerosene or alcohol, entirely covering the needle-card assembly. This liquid serves several purposes. It cleanses the bearing under the pivot and serves as a lubricant for it. It causes the needle-card assembly partially to float, taking most of the weight off the pivot and bearing and protecting the pivot and bearing from excessive vibration. The primary function of the liquid, however, is damping. The fins or baffles on the bottom of the needle-card must move through the liquid when the needle turns. The liquid exerts a braking effect on the needle, thus preventing over-swing and taking away the period. The top of the compass cup is glass, sealed on the cup so that it is air and liquid tight. The cup is filled through a filler-plug in the side.

Thus far, the compass has been described as a needle-card assembly suspended in a liquid-filled, sealed glass-top cup. In what manner, then, are the directions indicated? Viewed from above, the needle-card appears as represented below:

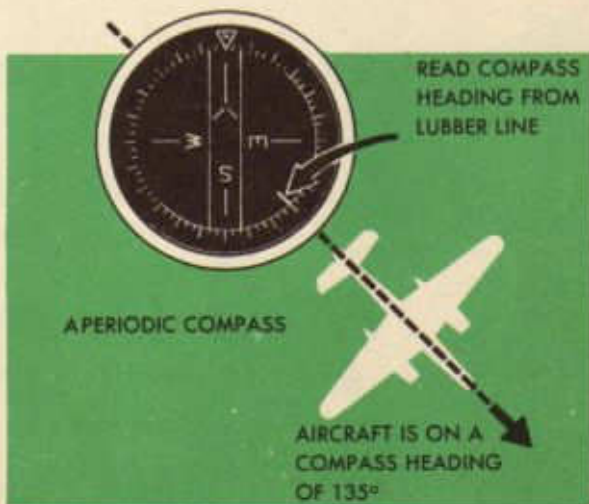

When the compass is in a level position, the needle card swings so that the blank end points toward the north. Then the line marked E points east, the S points south, and the W points west.

The heading of the plane is indicated on the compass by the *lubber line*. It appears as a pair of white lines, one above the other, about $\frac{3}{4}$ " long, attached to the inside of the cup and extending toward the center. When the compass is mounted in the aircraft, the lubber line is made to parallel the longitudinal axis of the aircraft and thus will indicate at all times the heading of the aircraft.

The portion of the compass which is used to measure angular distance between north



and the plane's heading is called the *azimuth ring* or *verge ring*. This ring, illustrated below, is attached, free to move, over the top of the compass cup. It consists of a metal ring, graduated in degrees and framing a round glass center. Across the middle of this glass center are drawn two parallel lines about $\frac{5}{8}$ of an inch apart. The azimuth ring assembly may be locked to the compass cup by means of set-screws located on the side.

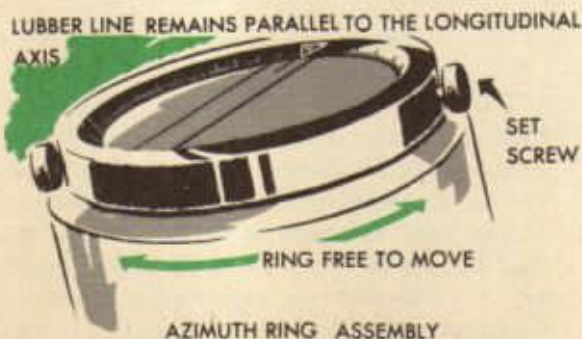

Now, to determine the heading which a plane is flying, or, as navigators say, "to follow the pilot," the azimuth ring is turned until the parallel lines on the glass are parallel with the north-south line on the compass card, with the blank end of the needle at the N or 0° on the azimuth ring and the S end at the S or 180° on the azimuth ring. The azimuth ring then is lined up north and south regardless of the heading of the aircraft. Remember that the lubber line is installed parallel to the longitudinal axis of the aircraft and, therefore, represents the actual heading of the aircraft. The angle between the north-south line represented by the compass needle, and the heading of the plane, represented by the lubber line, read in degrees on the azimuth ring at the lubber line, represents the heading of the plane.

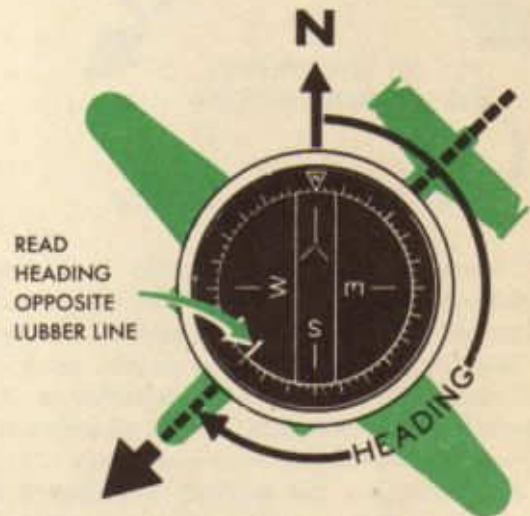

To set a course, the desired heading, 85° , for example, is set at the lubber line and the aircraft is turned toward the needle until the needle lines up parallel to the azimuth ring parallels, with the blank end of the needle at N or 0° and the S end at S or 180° . To correct a course, the aircraft is turned toward the needle until the needle is lined up parallel with the azimuth ring parallels as in setting a course.

Because of the fact that the compass needle is free to rotate only horizontally, the compass is accurate only when read in straight, level flight. When reading the compass, the navigator should place his eye directly above and in line with the upper and

lower parts of the lubber line. He must be very careful to align the azimuth ring exactly parallel with the needle before each reading of the compass.

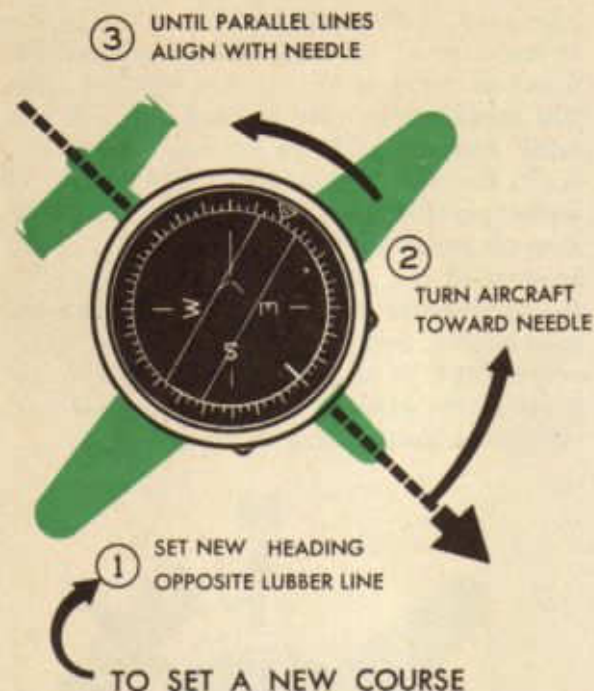

Underneath the compass cup is a tray which may be removed and into which may be placed small, round bar magnets. The use of these magnets will be explained later in the course. The compass is mounted in the aircraft to the navigator's right at seat level on special shock-absorbing mountings.

The navigator has another instrument in addition to the magnetic compass which is used to supplement the compass in keeping check on headings. On his instrument panel, he has a directional gyro turn indicator, commonly referred to as a *gyro compass*. This compass has four principal uses to the navigator:

1. To supplement the aperiodic compass in keeping check on the heading.
2. To show the magnitude of turns.
3. To aid in air swinging compasses.
4. To coordinate the navigator's and pilot's problems of directional control. The gyro compass has a vertical compass card (see figure below) which can be set by means of the caging knob on any desired figure of the compass rose (direction). Note

that the zeros have been deleted from the numerals on the card. The caging knob is pushed in to set the compass. Pushing in the knob throws the gyro mechanism out of gear, and the card can be turned by turning the knob to right or to left. When the aircraft's heading is set on the card, pull the knob out



to release the caging mechanism (to put the gyro back in gear). The gyro then holds the card in this position, independent of the movements of the plane. Hence, any change in the heading of the plane will be shown on this compass in the same manner as on a magnetic compass.

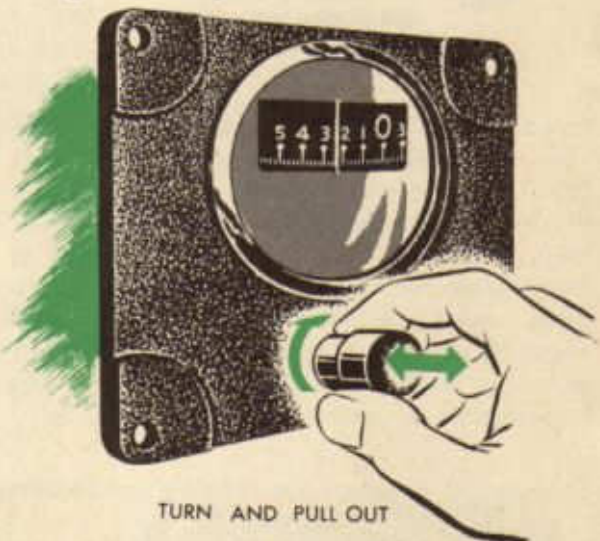

The gyro-compass has the advantage of having a completely stable card. There is none of the oscillation (swing) that is present on the magnetic compass. The weakness of the gyro compass is that it will precess, that is, it will creep away from the heading set. The rate of precession varies widely with different gyros, but few of them can be relied

on to keep within two degrees of a heading for more than an hour. It is necessary, therefore, to check the gyro-compass at frequent intervals by the magnetic compass and to reset it or to note its rate of precession.

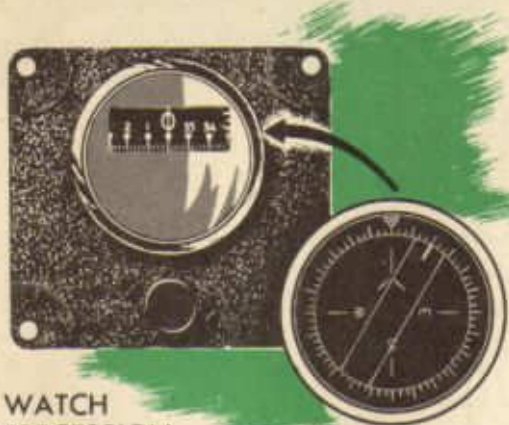

WATCH
PRECESSION

Thus far, north has been referred to simply as *north*. Unfortunately, there are three different norths from which to measure a direction or a heading. It is imperative, therefore, that the navigator be able to distinguish clearly between them. The term, *north*, is generally considered to mean the direction of the geographic north pole. Navigators refer to geographic north as *true north* and abbreviate the term with the letters TN. Headings measured from true north are called *true headings* and are abbreviated TH.

The discussion of magnetism has stressed the fact that a freely suspended magnet influenced only by the earth's undisturbed magnetic lines of force points only in the *general direction* of the north magnetic pole. The discussion stressed also that the north magnetic pole and the north geographic pole are not coincident, that is, they are not at the same place. Therefore, a magnetic needle, freely suspended and influenced only by the earth's undisturbed magnetic lines of force, points not toward the north geographic pole nor exactly toward the north magnetic pole, but to *magnetic north* or MN. Headings measured from magnetic north are called *magnetic headings* (MH).

The discussion of magnetism also pointed out the fact that a freely suspended magnetic

needle, such as a compass, very rarely is affected only by the earth's undisturbed magnetic lines of force. Almost always the earth's magnetic lines of force will be affected by magnetic disturbances in and about the plane, causing the needle to deviate from magnetic north and to indicate another north called *compass north* (CN). Headings measured from compass north are called *compass headings* (CH).

It follows, therefore, that any single heading may be indicated in three different ways: 1. true heading (TH), 2. magnetic heading (MH), and 3. compass heading (CH). These three ways of indicating the same heading are illustrated.

Examination of the diagram reveals that the aircraft is flying a heading which may be indicated as a true heading of 070, a magnetic heading of 060, or a compass heading of 063.

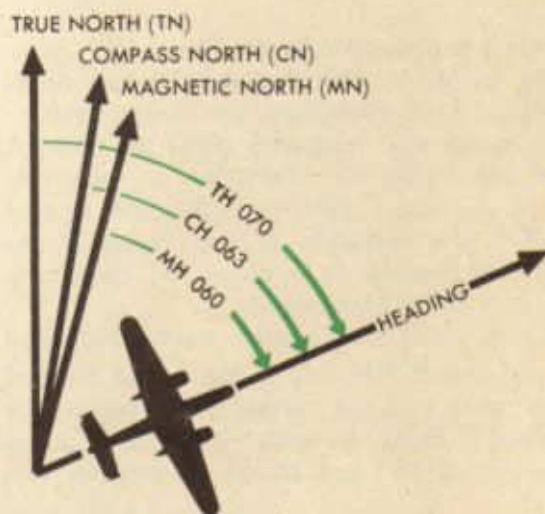

It has been pointed out that a compass needle, when affected only by the earth's undisturbed magnetic lines of force, will not point toward true north, but will point toward magnetic north. The angular distance, at any point on the earth's surface, between true north and magnetic north is called the *variation* of that point. Variation is called *west* variation when magnetic north lies to the left or west of geographic north, and *east* variation when magnetic north lies to the right or east of geographic north. The amount of variation may vary from 0° through 180°. Diagrams may prove helpful.

The diagrams are drawn with curved lines to represent the spherical surface of the earth. TN and TS represent the north and south geographic poles. MN represents the magnetic north pole. The lines TN-A-TS and TN-B-TS represent geographic meridians. The lines A-MN and B-MN represent the earth's lines of force through points A and B respectively. The line TN-D-MN-TS represents both a geographic meridian and a magnetic line of force. At point A, true



Chart-makers join points of equal variation by lines called *isogonic lines*. They are seen on the navigator's charts as broken lines with the amount and direction of the variation indicated. Chart-makers also join points having zero or no variation by a line called an *agonic line*.

The application of variation may be best understood by reference to the two diagrams. The first figure represents var. 10 E. Any east variation is handled in the same manner. Reference to the diagram shows that east variation must be subtracted from TH to give MH. It shows likewise that east variation must be added to MH to give TH. If the navigator wants to fly a true heading of 060 over territory having 10 E variation, he must fly a magnetic heading 060 - 10 or 050. Or, if the navigator sees by his compass that he is flying 050 MH over territory having 10 E variation, he knows that he is flying (or *making good*) a true heading of 050 + 10 or 060. The second figure reveals that west variation is *added* to TH to give

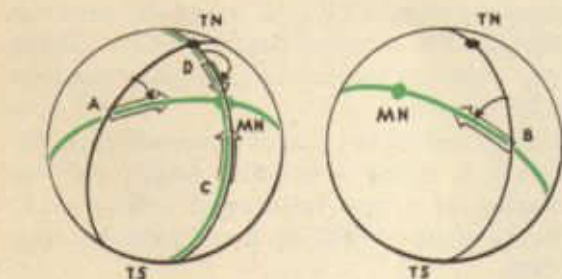

north is represented by the line A-TN; magnetic north, by the line A-MN. The angle TN-A-MN is, therefore, the angle between true north and magnetic north at point A and represents the variation at point A. Since, at point A, MN lies to the right or east of TN, the variation is east variation. In this case it seems to be about 35°, therefore, it would be written *var. 35 E*.

From point B, magnetic north, indicated by the line B-MN, lies to the left or west of true north and the variation represented by angle TN-B-MN is west variation. It measures about 45° and would be written *var. 45 W*.

A special condition is noted at point C. Here the compass needle, pointing to magnetic north, points also to true north; therefore, from point C there is no or 0 variation. Another special case is point D, located on the geographic and magnetic meridian between the north magnetic pole and the north geographic pole. Here, the compass, pointing toward the north magnetic pole, points exactly away from the north geographic pole. Variation here is 180° and is neither E nor W. The chief purpose of the figures is not to emphasize these special cases, but to show that variation varies in amount and direction at various locations on the earth's surface.

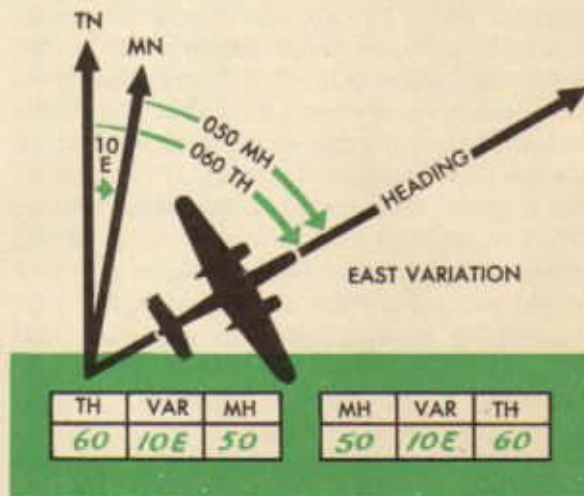

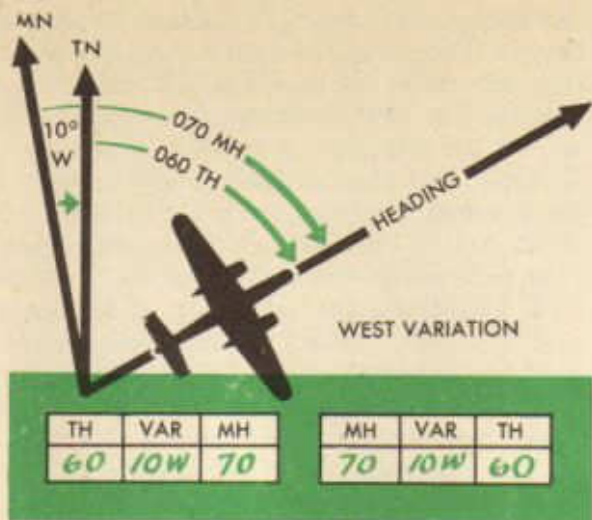

MH or subtracted from MH to give TH. Since Air Forces navigators generally are interested in going from TH to MH, the rule is stated: East is least (subtract); West is best (add).

As has been pointed out several times previously, a compass needle, when affected *only* by the earth's undisturbed magnetic lines of force, will point toward magnetic north. But it very seldom is the case that an aircraft compass needle is affected only by the earth's undisturbed lines of magnetic force. Always there are present in the aircraft many small magnetic fields, all of which twist and bend (*distort*) the earth's magnetic lines of force and thus cause the compass to point, not toward magnetic north, but toward another direction known as *compass north*. It is safe to assume *always* that compass north differs from magnetic north.

The angular difference between magnetic north and compass north on any heading is called the *deviation* of the compass on that heading. Deviation is found by subtracting compass heading from magnetic heading. The magnetic heading must be determined by some means other than the compass. The navigator will learn early how to use an instrument called the astrocompass for this purpose. But when the navigator obtains the magnetic heading of the aircraft, he subtracts the compass heading from it to get the deviation of the compass on that heading. For example, if the magnetic heading is 058 and the compass heading is 055, the deviation

on that heading is 058 - 055 or +3. Or, if the magnetic heading of the aircraft is 075 and the compass heading is 077, the deviation on that heading is 075 - 077 or -2.

The deviation of a compass on all headings is determined and recorded on a card called a *deviation card*, and the card is always installed somewhere near the compass in the aircraft. How this deviation card is made up will be explained later; its use

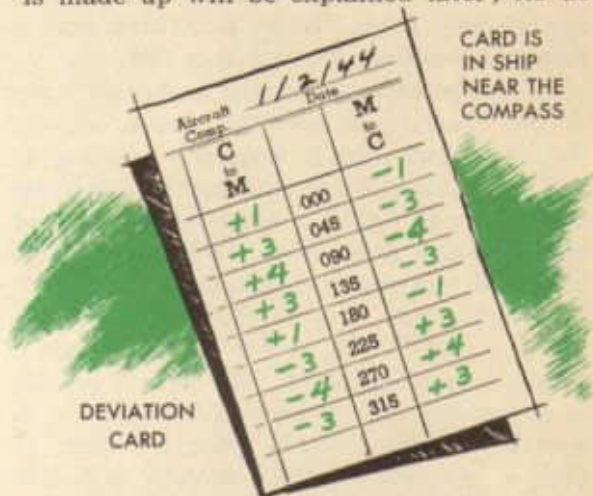

is of interest now. The official AAF deviation card form is reproduced below, with the blanks filled in, as they would be in an aircraft.

If the navigator looks at his compass and sees that it is reading 040, he realizes that 040 is compass heading *only* and may be different on every compass in the aircraft. He

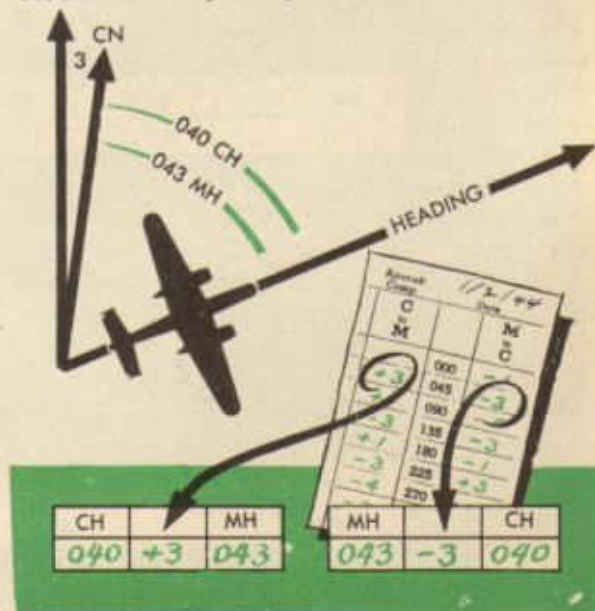

wants to know magnetic heading so that he can apply variation to it and get his true heading. He looks at the deviation card for the compass and since he knows compass heading and wants to know magnetic heading, he looks in the C to M (Compass to Magnetic) column. If his deviation card were the one illustrated here, he would see +3 in the C to M column by 045, which is close enough to 040. He knows, then, that when his compass reads 040 he is making good a magnetic heading of $040 + 3$ or 043.

If, on the other hand, the navigator looks at his chart, gets his true course, applies variation and gets a magnetic heading of 043, he wants to know what compass heading to fly to make good a magnetic heading of 043. He looks at the M to C column, since he knows M and wants C, and finds -3 by 045. He knows, then, that he must fly a compass heading of $043 - 3$ or 040 to make good a magnetic heading of 043. The M to C column is sometimes called *deviation correction* in contrast to the C to M column, which, of course, is deviation. The student will note that deviation and deviation correction on any heading are the same in amount, but of opposite signs.

The deviation card gives information only

on headings 45° apart, as the card illustrated shows. The navigator must *interpolate* (split the difference) for headings in between those shown. The card illustrated shows deviation of +1 for 000 and +3 for 045. That means, roughly, that the navigator would apply +1 to compass headings from 000 to 010, +2 from 011 to 034, and +3 from 035 to 045. The card shows also that deviation on 090 is +4. Therefore, the navigator would apply +3 from 045 to about midway between 045 and 090 or to 067, and +4 from 068 to 090. The navigator expects no difficulty on this procedure, once he gets the hang of it.

The compass, then, is subject to two errors, variation and deviation. Variation, once determined for a certain locality, is the same on all headings and on all compasses in that locality. The amount of variation is noted on various navigation charts. Deviation, however, differs on various headings and is not the same, except accidentally, on any two compasses. Deviation changes on a given compass for any number of reasons, including jars, jolts, or twists of the aircraft, and moving the aircraft north or south for a considerable distance. Deviation is recorded on the compass-deviation card and must be checked frequently, as will be discussed later.

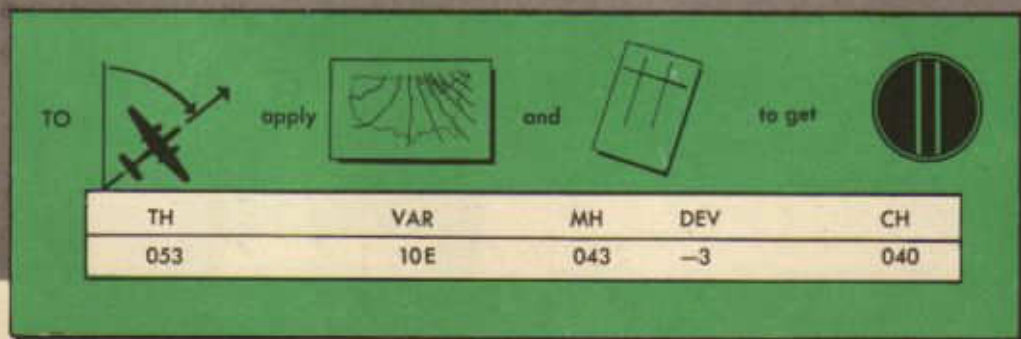
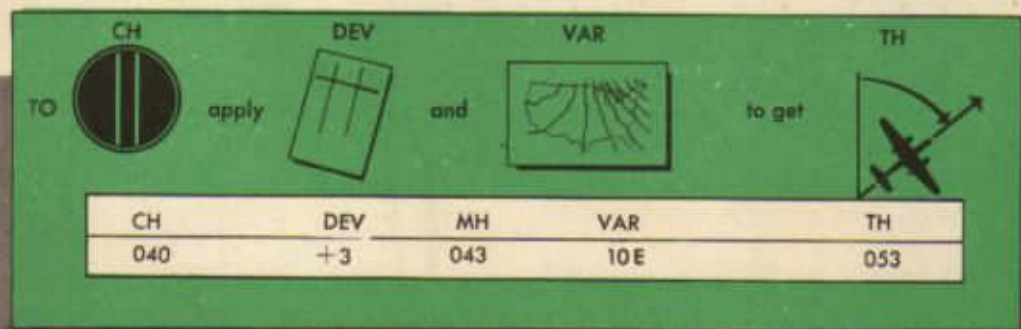

ALTITUDE

It is well to recall that an aircraft in flight moves not only from side to side (in a horizontal plane), but also up and down (in a vertical plane). It already has been shown that the navigator keeps track of the horizontal position of the aircraft by means of an instrument called the compass. It is necessary for him to keep track also of the aircraft's vertical position. An aircraft's vertical position is called its *altitude*. Altitude may be defined as vertical distance above some point used as a reference point. It follows, then, that there may be as many kinds

of altitude as there are reference points from which to measure. The navigator is concerned, generally, with only three kinds. Altitude above *sea level* is called *true altitude*. Altitude above *the ground* is called *absolute altitude*. Altitude above the *standard datum plane* (a theoretical plane containing all points where the air pressure, corrected to 15°C, is 29.92"Hg) is called *pressure altitude*. The *altimeter* (pronounced al-tim'-e-ter) is an instrument used for measuring altitude by measuring the pressure of the column of air *above* the aircraft.

Pressure may be defined as the weight of the air above any point. It is measured, not in pounds, but in terms of the height, in

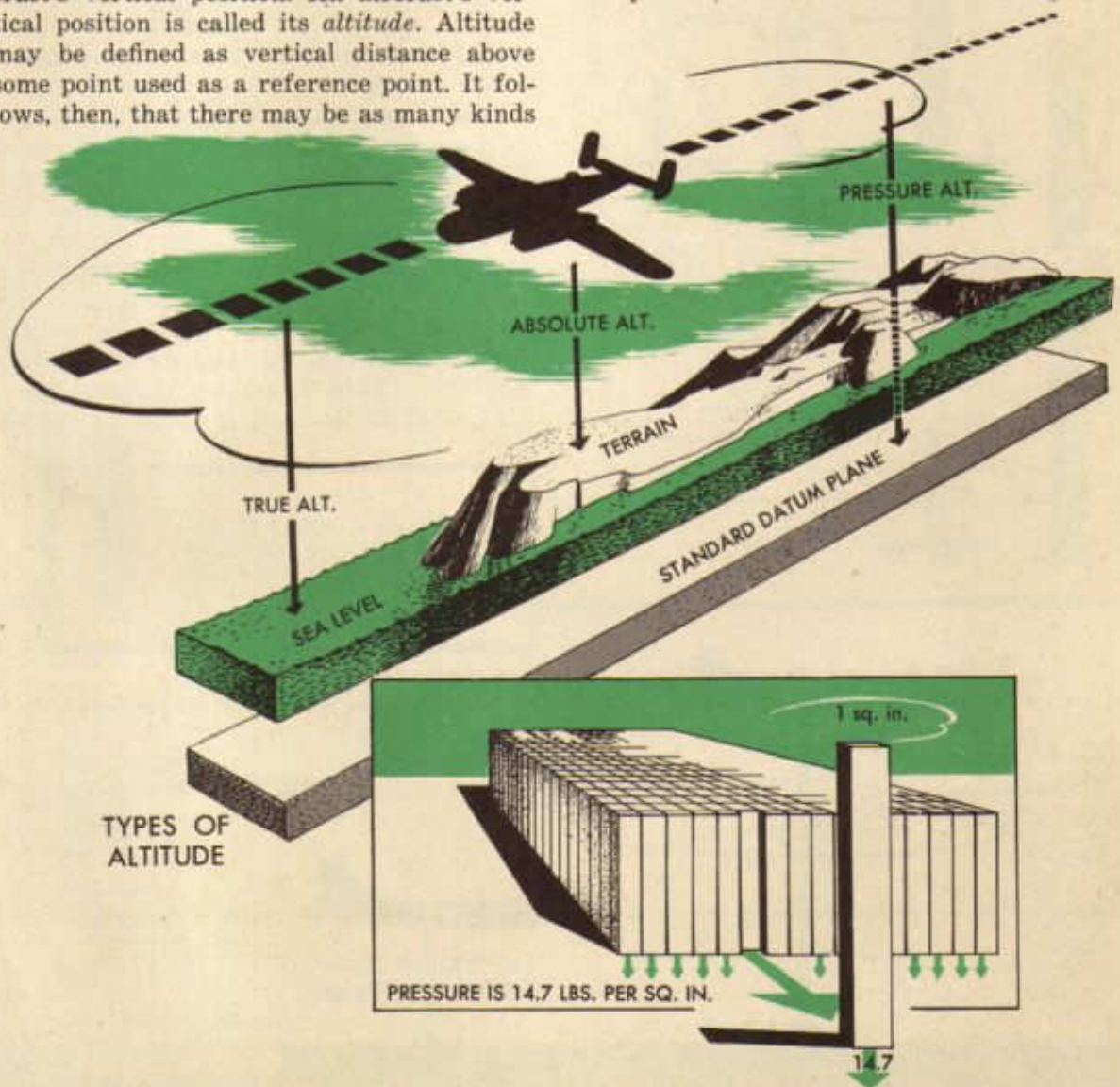

inches, of a column of mercury (Hg) which would have the same weight as the air. To say, for instance, that the pressure at a given place and time is 30.02"Hg is to say that the weight of the air above the place at that time is such that it exerts the same pressure per square inch as would a column of mercury 30.02 inches high.

Scientists have found that the air exerts, roughly, a pressure of one inch of mercury per thousand feet of height. Thus, a column of air exerting a pressure of 30.10"Hg might be approximately 30,100 feet in height. But

scientists have found also that cold air is heavier than warm air; therefore, a column of warm air is higher than a column of cold air exerting the same pressure. They have found also that a column of air may not be the same temperature from top to bottom, thus further complicating matters. The height of a column of air can be calculated accurately, therefore, only when both the pressure and the temperature of the air are known. The

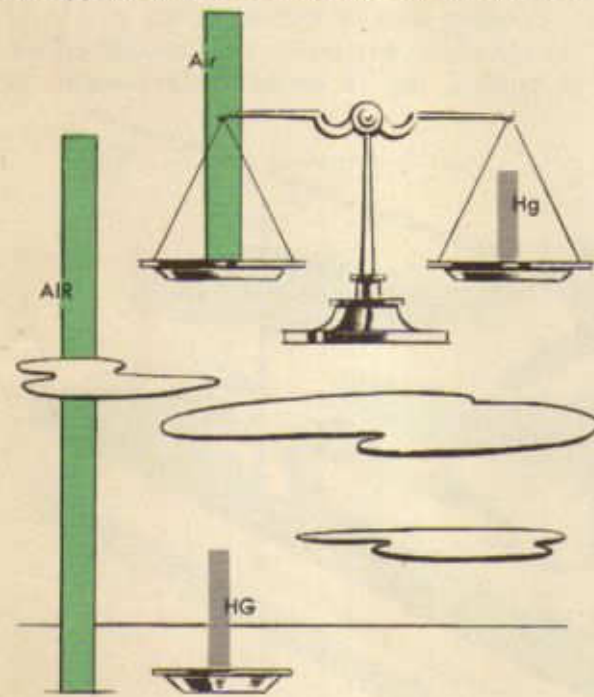

Cold air heavier than warm air



combination of pressure and temperature is called *density*.

How, then, can the altitude of an aircraft be measured by measuring the pressure of the air above it? Consider the diagram below. Remember that scientists have found that air exerts a pressure of approximately one inch of mercury for each thousand feet of height. If the pressure at the reference point, therefore, is 30.34"Hg, when the aircraft has risen 340 feet, the pressure will decrease $340/1000''$ (0.34''), making the pressure at that point $30.34 - 0.34$ or 30.00. As the air-

1000' OF STANDARD AIR EXERTS ABOUT THE SAME PRESSURE AS 1" OF HG.

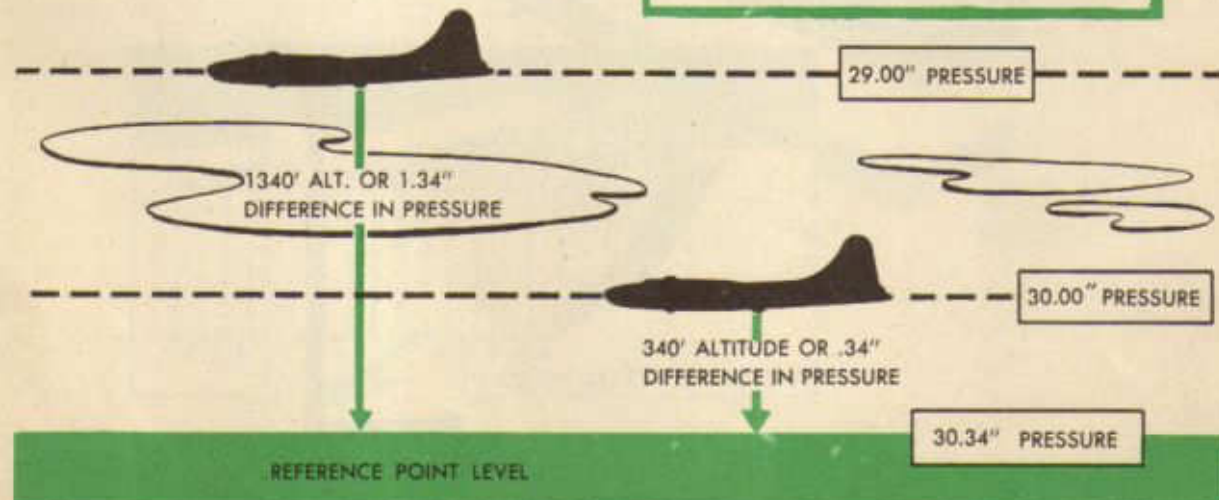

craft rises, the pressure will decrease 1.00" Hg for each thousand feet risen. In other words, when the aircraft rises from 340' to 1,340', the pressure decreases 1.00" from 30.00" to 29.00" and so on. If the navigator knows that the pressure at the field is 30.34", he knows that when he is at a point above the field where the pressure is 29.00" he is 1,340' above the field. If an instrument can be devised, therefore, to measure air pressure, it can be used to measure altitude.

Such an instrument has been devised and it consists essentially of an aneroid cell, a system of linkage, and a dial and pointer arrangement. An aneroid cell is composed of a small number, usually three, aneroid wafers. An aneroid wafer is made of two circular pieces of very strong, thin, flexible metal welded together at the edges. Air is pumped between the two pieces until a certain pressure is developed, pushing the sides out somewhat. The aneroid wafer responds

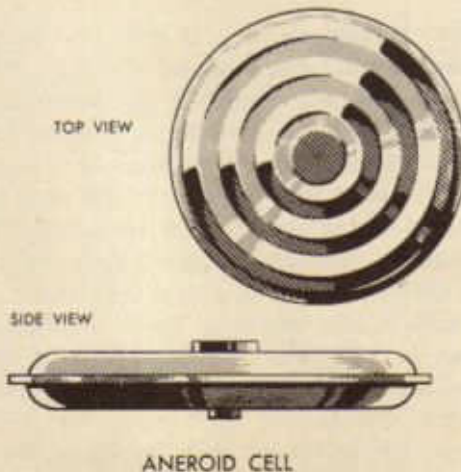
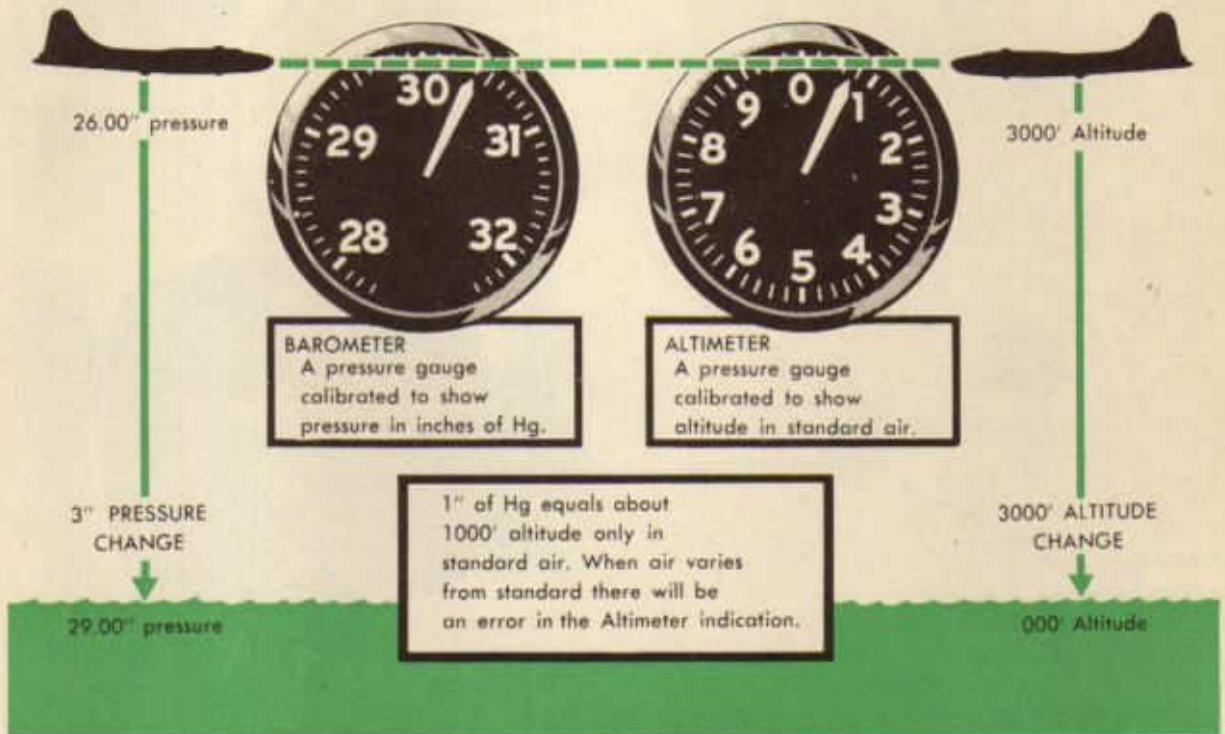

to variations in air pressure very much as does a small rubber balloon that is inflated. When the balloon is inflated it expands to a point at which the pressure of the air outside the balloon plus the pressure of the rubber of the balloon balances the inside air pressure. As long as the outside air pressure remains the same, the balloon stays the same size. When the outside air pressure becomes less, the balloon expands until balance is

restored. Or if the outside air pressure increases, the balloon gets smaller. The aneroid wafer acts in the same manner, as illustrated below.

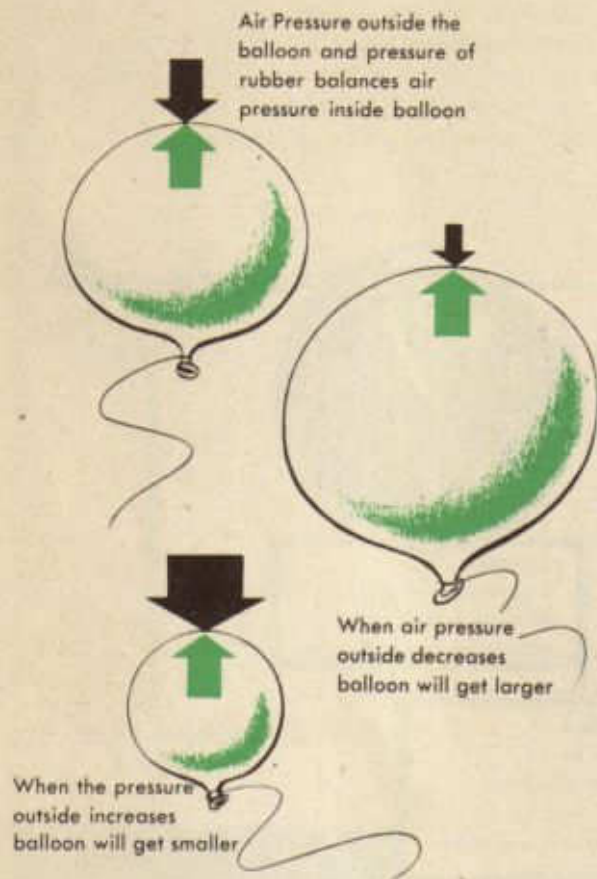

Several aneroid wafers, joined together to form an aneroid cell, act in the same manner as the single wafer.

Consider a simple instrument for measuring air pressure. One side of an aneroid cell is attached to a stationary post; the other side is left free to move. One end of a pivoted pointer is attached to the free side of the cell; the other end is free to move over a scale. Such an assembly is illustrated. Variations in air pressure cause the aneroid cell to expand or to contract, moving the pointer over the scale.

When the scale is printed to indicate pressure in inches of mercury, the instrument is called a *barometer*. When the scale is printed to indicate altitude in feet, the instrument is an *altimeter*.

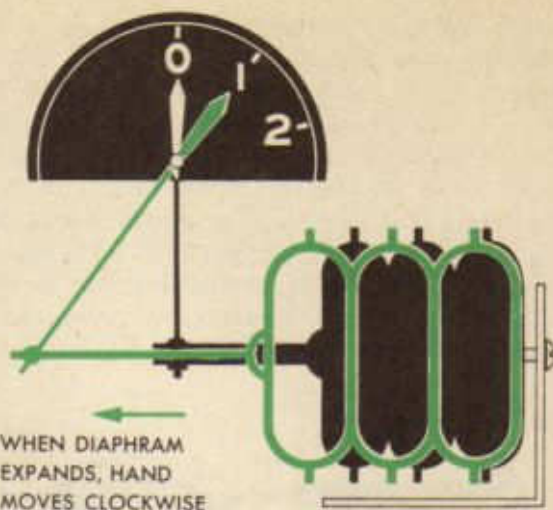

The altimeter with which the navigator most likely will work is the C-10, the dial face of which is shown below:



The altitude, in feet, is read on the altitude scale around the edge of the dial. The altitude scale is divided into ten positions, numbered 0-9. Each division is divided into five sub-divisions. Three pointers move over the dial: a long thin pointer which may be compared to the sweep-type second hand on a watch, a shorter pointer which corresponds to the minute hand, and a very short pointer which is like the hour hand. These pointers may be referred to respectively as the second hand, the minute hand, and the hour hand. The second hand measures altitude in hundreds of feet; that is, when the plane rises 500 feet, the second hand moves over

five divisions on the dial, from 4 to 9, for instance. By means of sub-divisions, the second hand will measure as little as ten or twenty feet change of altitude. The minute hand measures altitude in thousands of feet; that is, when the plane rises a thousand feet, the minute hand moves over one division of the dial, say from 2 to 3. The minute hand makes one complete revolution of the dial while the second hand is making ten. The hour hand measures in tens of thousands of feet and makes one revolution of the dial while the minute hand is making ten and the second hand is making one hundred. Most altimeters in service have a range of 0 to 35,000 feet, although there is a limited number of altimeters calibrated to 50,000 feet. The face pictured in the illustration below reads 16,440 feet altitude.

On the right hand side of the dial is a small window which reveals a barometric (Air Pressure) scale. A stationary index marker opposite which barometric pressure

may be read is attached to the dial face. This scale, being a barometric scale, indicates air pressure in inches of mercury. The scale covers a range of pressure from 28.1" to 31.0" of mercury with graduations of .02". Two triangular reference markers, each movable with respect to the graduated altitude scale, may be found above and below the zero position on the altitude scale when the barometric scale indicates 29.92". A setting knob at the bottom of the face of the altimeter enables any desired pressure to be set on the instrument. The pointers then indicate altitude above that pressure. For instance, if 30.02" is set on the barometric scale, the pointers indicate altitude above all places where the pressure is 30.02". It is important to remember that this 30.02 will remain set on the altimeter until the setting knob is again turned.

With the description of the altimeter in mind, it is well to consider what use the navigator makes of the instrument in actual

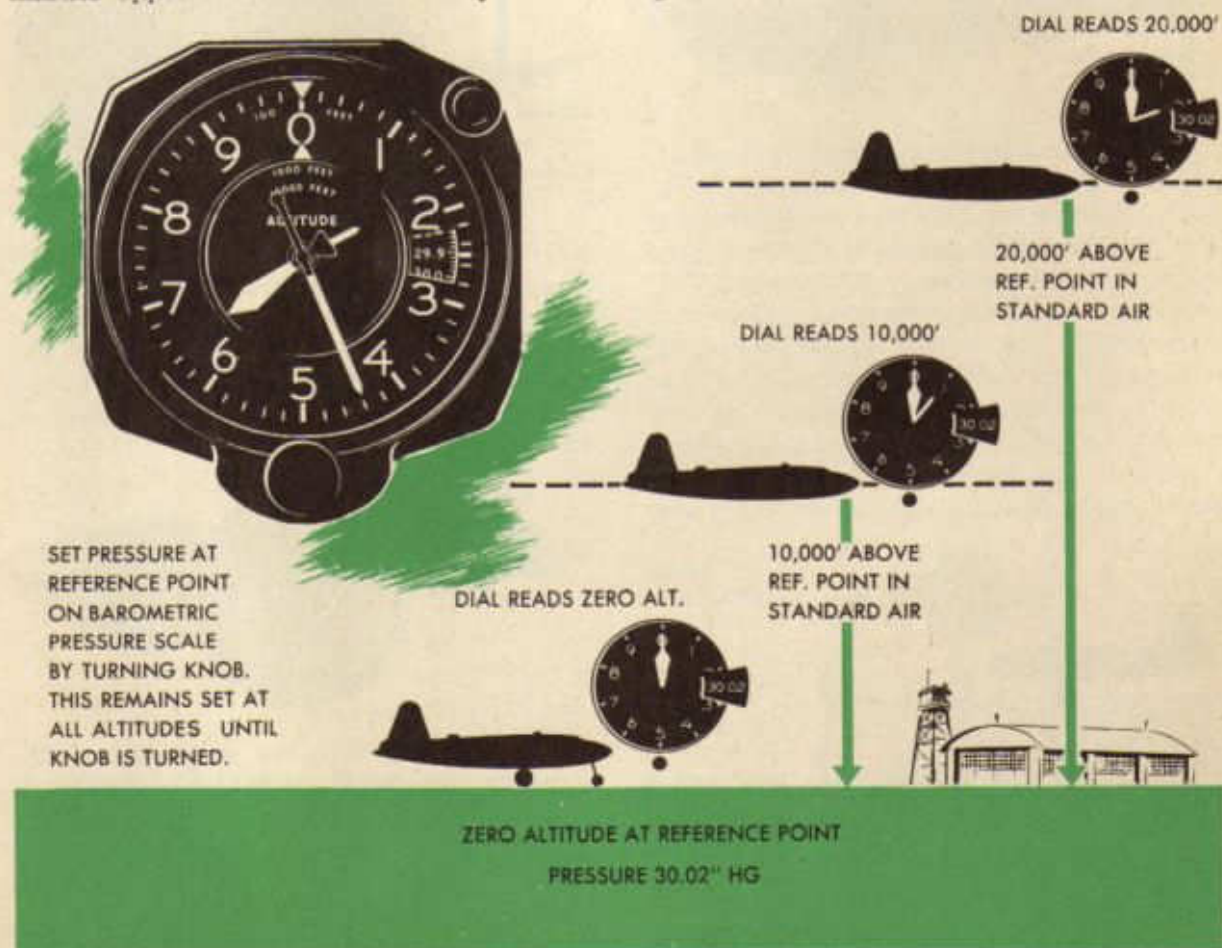

flight. It has been indicated that first a pressure is set on the barometric scale by means of the setting knob. Then the altimeter will read the altitude in feet above all points at which the pressure is the same as that set on the barometric scale. For all military purposes, army regulations require that *altimeter setting* be set on the barometric scale. Altimeter setting is the local station pressure reduced to sea level. For example, on a field where the elevation is 340 feet, the actual barometric pressure at a certain time is found to be 29.96. Imagine that on the field a shaft is sunk a depth of 340 feet. The bottom of the shaft would be, then, exactly at sea level.



If a barometer were carried to the bottom of the shaft, it would read approximately 30.30, which would be the *altimeter setting* for the field. Meteorologists calculate altimeter setting from station pressure by formula. The navigator can obtain approximate altimeter setting simply by setting up the surveyed elevation of the field plus ten feet (for the aircraft's height above the ground) on the face of the altimeter. Altimeter setting, then, is opposite the index marker on the barometric scale. When altimeter setting is set

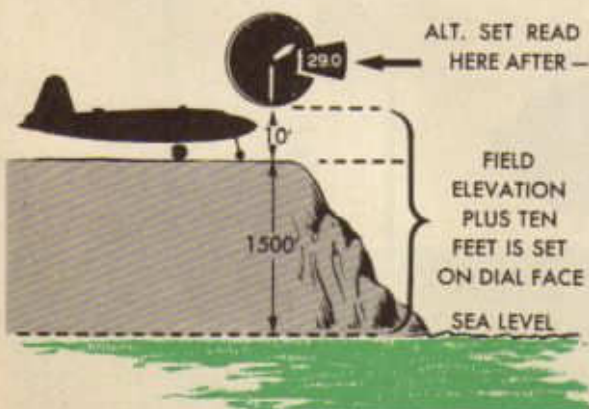

on the altimeter, true altitude is indicated by the pointers on the face of the altimeter. It must be remembered always that the altimeter measures only the distance above points where barometric pressure is the same as that set on the altimeter.

Since a column of cold air is heavier than a column of warm air of the same height, it is imperative that the navigator have some means of measuring the temperature of the

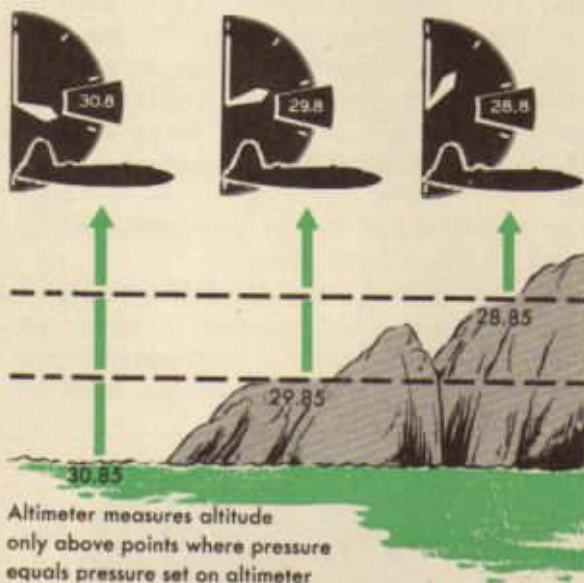

air outside of and surrounding the aircraft at any altitude. This problem is solved by the *free air temperature gauge*, which indicates the temperature of the air *outside* the aircraft in Centigrade degrees. A sketch of the face of the free air temperature gauge is shown below:



In connection with the temperature surrounding the aircraft, it is well to remember a phenomenon which becomes especially dangerous when flying over high terrain. An altimeter in air colder than the expected atmospheric temperature at a given altitude will indicate an altitude higher than the

actual height of the aircraft. Or conversely, the altimeter will indicate that an aircraft is lower than it actually is when the surrounding temperature is warmer than the expected temperature at that altitude. Temperature is assumed to decrease at a rate of approximately 2°C per 1,000 feet increase in altitude. Thus, it is important to consider predicted temperatures and their effect on altimeter indications before deciding upon the flight altitude.

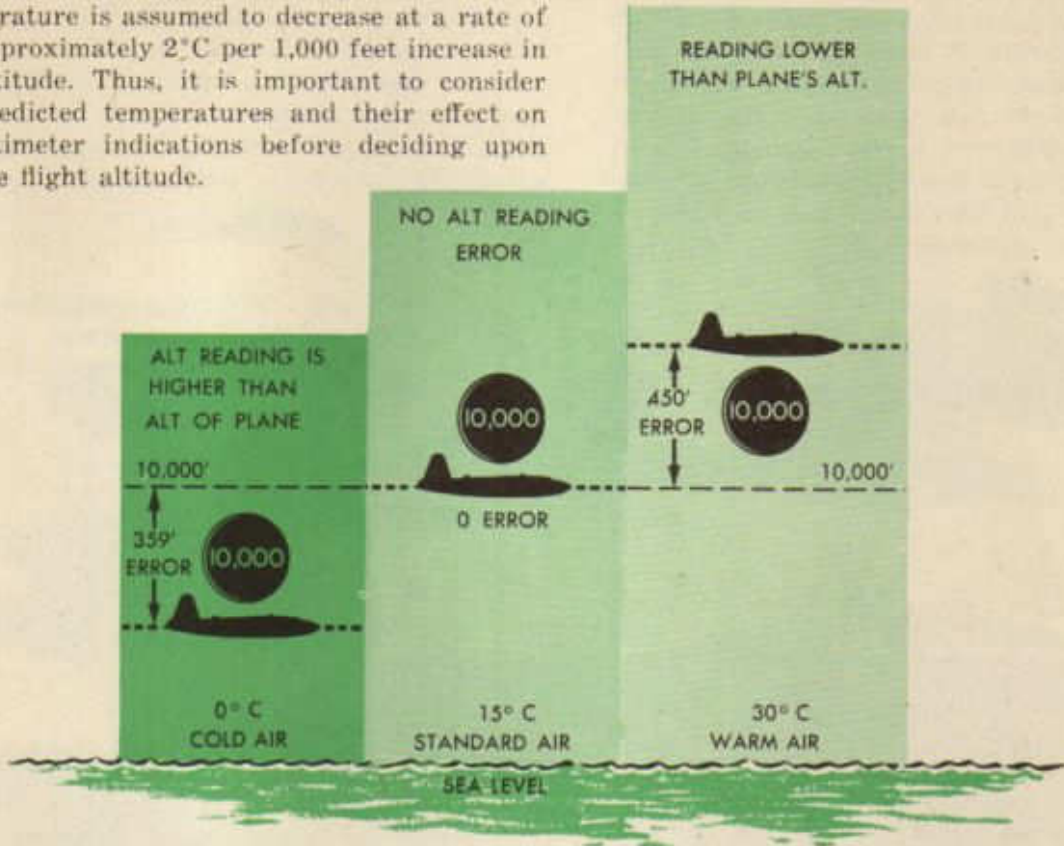

By the use of the altimeter and the free air temperature gauge, the measurement and computation of altitude may be divided into three distinct steps.

The first step concerns the altitude indicated by the hands on the face of the altimeter. This is called *indicated altitude*. Whether it is indicated true altitude, indi-

PRESSURE LEVELS VARY WITH TEMP. THE PRESSURE LEVEL IS HIGHER IN WARM AIR AND LOWER IN COLD. SINCE THE ALTIMETER MEAS. PRESSURE CALIBRATED TO ALTITUDE BETWEEN PRESSURE LEVELS THERE IS AN ALT. ERROR WHEN THE AIRCRAFT IS NOT IN STANDARD AIR

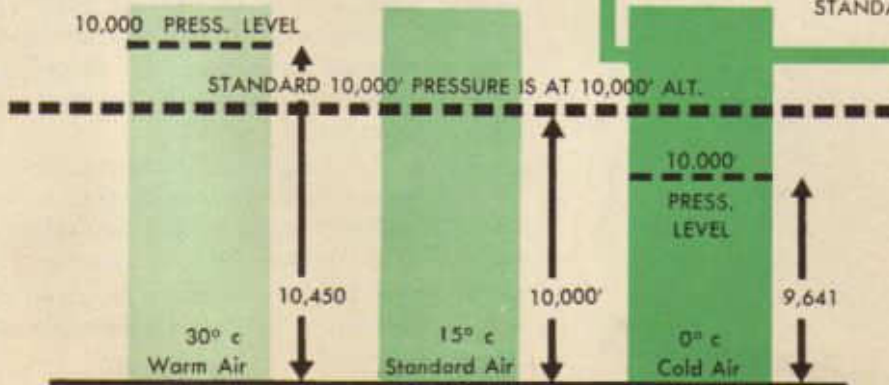

cated absolute altitude, or indicated pressure altitude depends upon what is set on the barometric scale. If *altimeter setting* is set on the barometric scale, *indicated true altitude* is read from the face of the altimeter. If field barometric pressure is set, *indicated absolute altitude* is read. If 29.92" is set on the barometric scale, *indicated pressure altitude* is read from the face of the altimeter. But in any case, whatever is read from the face of the altimeter is indicated altitude of some type, the type depending upon whatever is set on the barometric scale.

The second step in the measurement of altitude is the application of *scale error correction* to this indicated altitude to obtain *calibrated altitude*. Scale error results from defects within the altimeter itself and is recorded on a card hanging near the face of the instrument. If no card is present, it is assumed that there is no scale error, in which case calibrated altitude is assumed to be the same as indicated altitude. In cases where scale error is present and recorded, it will

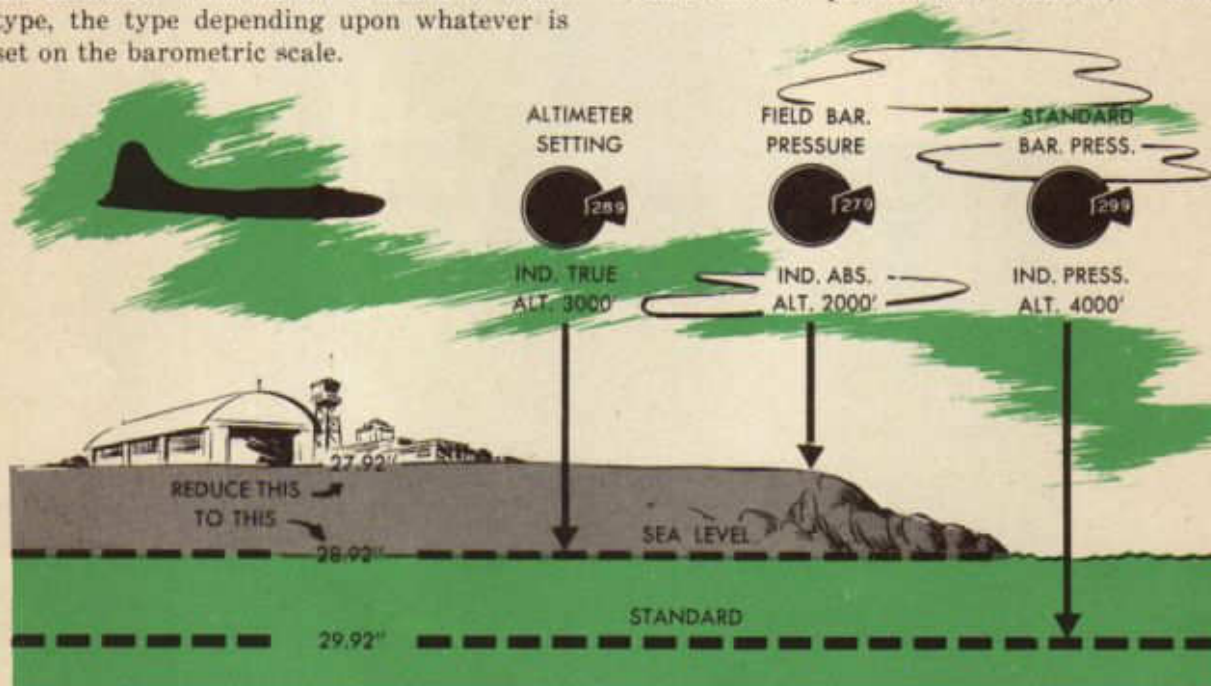

IND. ALT. + SCALE CORR. = CAL. ALT.
CAL. ALT. IS SAME TYPE OF ALT. AS IND.

SCALE CORRECTIONS		
Altimeter Reading	ADD	
	Temp.	Low Temp.
0		
500		
1000		
1500	+10	0
2000		
2500	+20	0
3000	+25	-10
4000		
6000	+25	-5
8000	+10	+2
10000	+20	+5

ALTIMETER No.		
Altimeter Reading	ADD	
	Temp.	Low Temp.
12000	+50	+5
14000		
16000	+250	+100
18000	+200	+100
20000		
22000		
24000		
26000		
32000		
35000		

TESTED BY: _____ DEPOT: _____

DATE: _____

be noted as plus or minus so many feet. The number of feet indicated on the correction card is added to or subtracted from the indicated altitude and the result is *calibrated altitude*. For example, if indicated altitude is 1,115' and the scale error is -75', the calibrated altitude is 1,115' - 75' or 1,040'. Note that this calibrated altitude will be the same type of altitude (true, absolute, or pressure) as is the indicated altitude to which the scale error correction is applied.

The third and last step in the measurement of altitude is the correction of calibrated altitude for density error to get *corrected altitude*. This correction for density error is different from and in addition to scale error and it must not be confused with scale error.

Density error exists because the altimeter is constructed so that it works perfectly only in a pressure of 29.92" and in a temperature of 15°C. When either condition is changed the error must be computed and the calibrated altitude corrected. This correction for density error is applied in two steps; namely, (1) a *pressure correction* and (2) a *temperature correction*.

Two methods may be used to find the pressure correction, the reference marker method and the arithmetic method. Pressure correction found by the reference marker method is read directly from the face of the altimeter by properly interpreting the relative positions of the two reference markers. When 29.92 is set on the barometric scale, the reference markers are located one exactly under the other at the very top (zero position) of the altimeter dial.



ZERO CORRECTION

If a pressure of less than 29.92 is set on the barometric scale, 29.42 for instance, the reference markers will move clockwise to the position indicated in the following diagram. It may be noted that the inside reference marker is to the right of the zero. This fact denotes two important things: first, that the amount of the correction will be read clockwise from the zero and, second, that the sign of the correction will be plus. It may be noted also that the outside reference marker is at approximately 470. The pressure correction



PLUS
CORR.

READ
CORRECTION
CLOCKWISE

is, therefore, +470. This 470 is added to any altitude read from the altimeter while 29.42 is set on the barometric scale in order to correct the altitude read for that part of the density error caused by having 29.42 on the barometric scale instead of 29.92.

If a pressure greater than 29.92 is set on the barometric scale, 30.42 for instance, the reference markers will move *counter-clockwise* from their zero (29.92) position to the position indicated in the drawing.



MINUS
CORR.

READ
CORRECTION
COUNTER
CLOCKWISE

It may be noted that in this case the inside reference marker is to the left of the zero. This fact denotes two important things: first, the amount of the correction will be read counter-clockwise from the zero, and, second, the sign of the correction will be minus. It may be noted also that the outside reference marker indicates approximately 460 (reading counter-clockwise from zero). The pressure correction is, therefore, -460'. This 460' is subtracted from any altitude read from the altimeter while 30.42 is set on the barometric scale.

The arithmetic method may be used to obtain a close approximation of pressure correction. Since the pressure altitude is the altitude above the standard datum plane, or the altitude above the plane containing all points where the pressure, corrected to 15°C, is 29.92; and since atmospheric pressure changes at the rate of approximately one inch of mercury for each thousand feet of vertical ascent or descent, pressure correction may be obtained by comparing the barometric pressure setting on the altimeter with the standard pressure, 29.92, and converting the difference in pressure to feet at the rate of 1,000' for each 1.00" of pressure.

If an aircraft is flown with an altimeter setting of 30.42 and the altimeter shows a calibrated true altitude of 2,500', what is its pressure altitude? Since the altimeter setting is greater than 29.92, the level at which this altimeter setting pressure exists is *below* the standard datum plane. In other words, the altitude above the standard datum plane is *less* than the altitude above the level at which this altimeter setting pressure exists. Therefore, the pressure correction is *subtracted* from the calibrated altitude in this case. The amount of the correction is determined numerically by remembering that the pressure changes at the rate of approximately 1 inch of mercury per thousand feet. Thus,

30.42" altimeter setting
 29.92" standard pressure setting
 .50" \times 1,000 or 500' pressure correction

Then:

2,500' calibrated true altitude
 -500' pressure correction
 2,000' pressure altitude

When the altimeter is less than 29.92, the pressure correction is added to the calibrated true altitude to obtain the pressure altitude. This may be shown by diagram.

If an aircraft is flown with an altimeter setting of 29.42 and the altimeter shows a calibrated true altitude of 1,800', what is the pressure altitude? When the altimeter set-

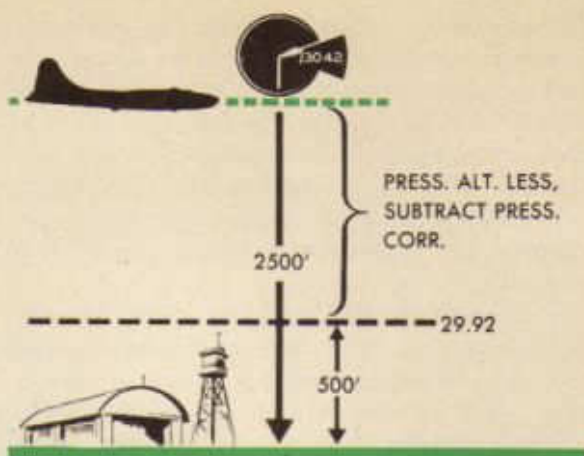

ting (29.42) is less than the pressure at the standard datum plane (29.92) it becomes apparent from the diagram that pressure altitude must be greater than calibrated true altitude. In other words, the level at which the pressure is greater must necessarily be lower than a level at which a lesser pressure is present. In the diagram the altimeter setting is less than 29.92; therefore the aircraft is higher above the standard datum plane than it is above the level at which the pressure is 29.72. Thus, the pressure correction must be *added* to the calibrated true altitude in order to obtain pressure altitude. The amount of the correction may be computed as before:

FOR PRESSURE ALTITUDE

IF ALT. SET IS LESS THAN
 29.92, ADD PRESSURE CORR.,
 SUBTRACT PRESSURE CORR.
 IF MORE.

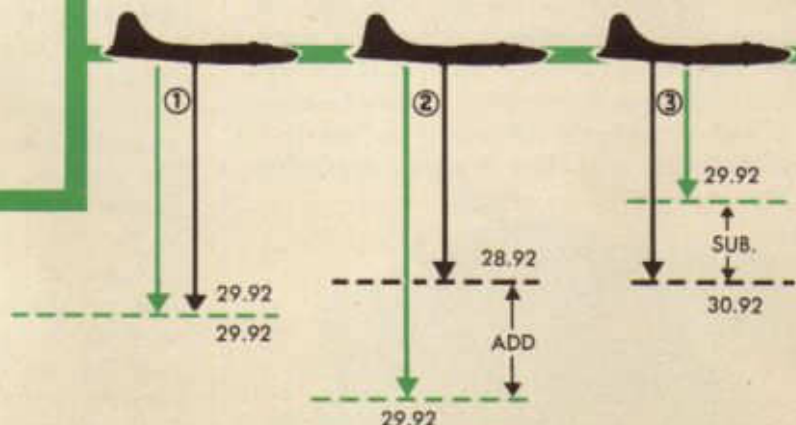

STANDARD CAN BE ① AT ② BELOW ③ ABOVE SEA LEVEL

29.92" standard pressure setting
 29.42" altimeter setting
 .50" \times 1,000 or 500' pressure
 correction

Then:

1,800' calibrated true altitude
 +500' pressure correction
 2,300' pressure altitude

Upon comparing the pressure corrections obtained by each of the two methods, the navigator will note a discrepancy of 30' to 40'. Which method is the more accurate? Compare the results of the two methods with the *Altitude-Pressure Table*, which is accurate and which is found as Table XV, page 215, TM 1-208, *Air Navigation Tables*.

Barometric Pressure Setting	Reference Marker Correction	Arithmetic Correction	TM 1-208 Correction
29.42	+470	+500	+467
30.42	-460	-500	-458

This comparison shows that the reference marker method is more accurate and is to be preferred.

Attention is called to the fact that when the navigator applies pressure correction to any altitude reading, the resulting figure represents what the altimeter would have read had 29.92 been set on the barometric scale. If 29.92 had been set on the barometric scale, the altimeter would have been indicating altitude above 29.92. Altitude above the pressure 29.92 is altitude above the standard datum plane, or pressure altitude, as has been said before. Therefore, when the navigator applies pressure correction to a calibrated altitude reading, say calibrated true altitude, the resulting figure represents pressure altitude. In other words, application of the pressure correction converts any calibrated altitude reading to which it is applied into pressure altitude. There is no distinction between calibrated pressure altitude and corrected pressure altitude. A clear understand-

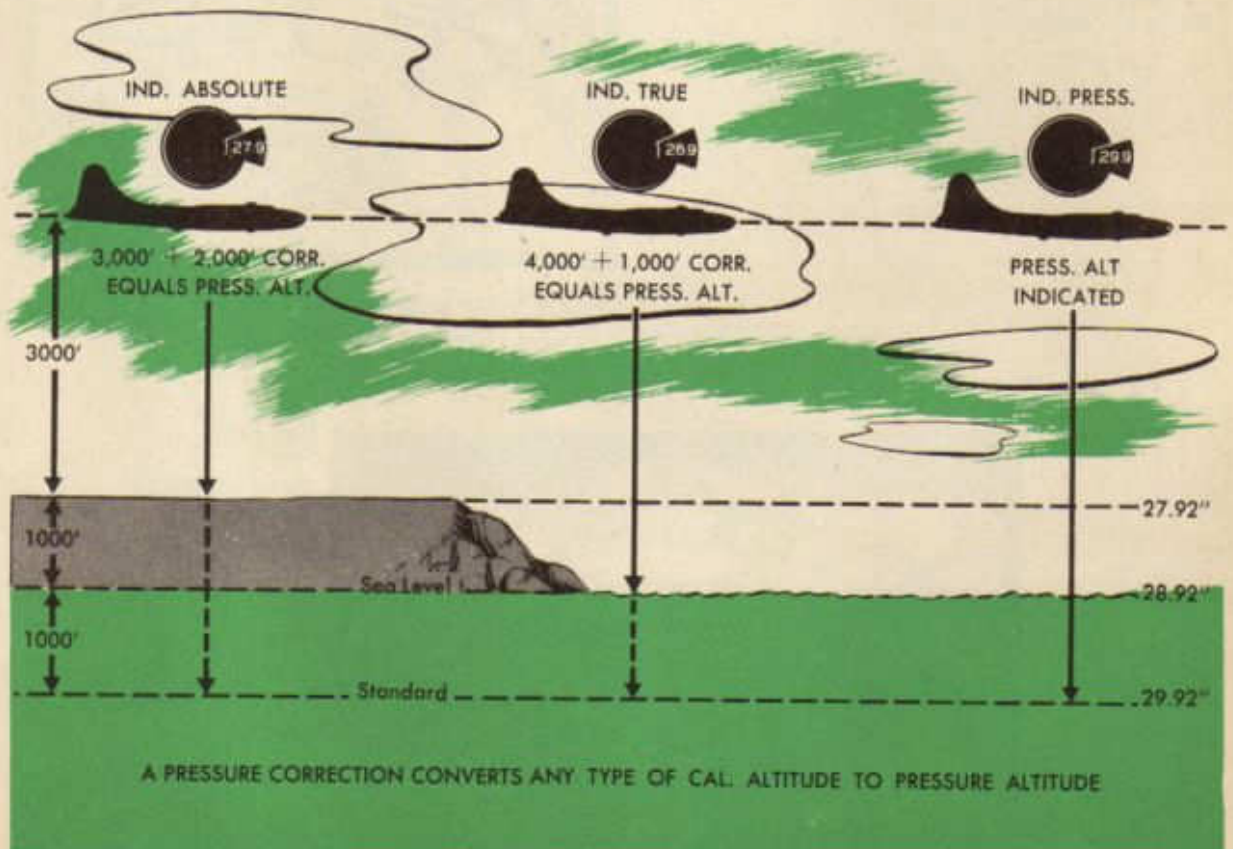

ing of this fact is important.

If the navigator is interested in determining pressure altitude only, he may stop at this point. At various times, however, it is necessary for him to obtain corrected true or corrected absolute altitude. At such times he will take the second step in altitude correction, namely, the application of the *temperature correction*, which is done on the computer. To set up the computer to correct for temperature, the navigator uses the window captioned "For Altitude Corrections" on the slide rule face of the computer. At this window he sets pressure altitude opposite temperature. He then reads corrected altitude on the stationary (miles) scale opposite calibrated altitude on the movable (minutes) scale.

Consider the following problem, which illustrates the steps in arriving at pressure altitude or corrected true altitude:

Altimeter setting: 30.34

Indicated altitude: 15,340

Scale error correction: -140

Pressure correction, read from reference markers: -390

Free air temperature: +10°C.

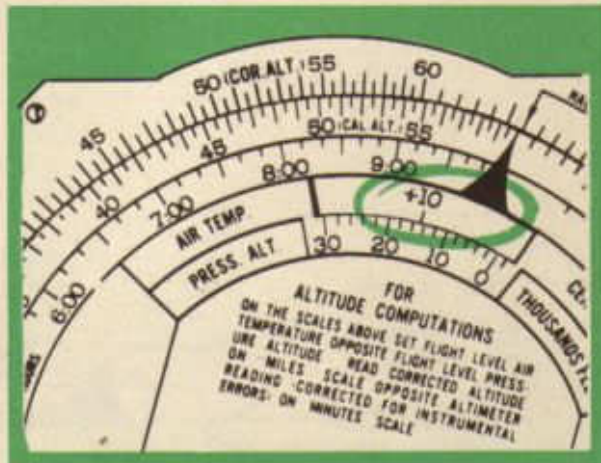
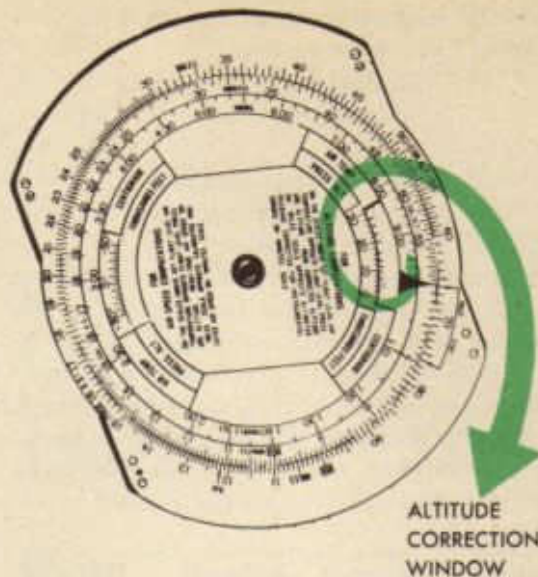

1 SET PRESSURE ALTITUDE AGAINST TEMPERATURE

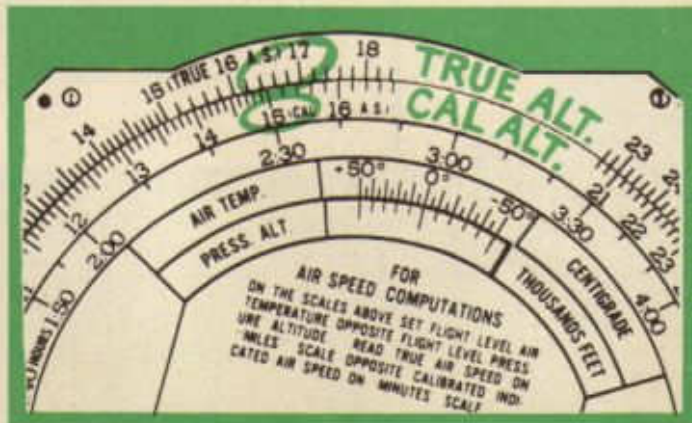

2 READ CORRECTED TRUE ALT. OPPOSITE CAL. TRUE ALT.

Find (1) pressure altitude and (2) corrected true altitude. Following the procedures already discussed, the navigator proceeds as follows:

1. To indicated true altitude (15,340) he applies scale error correction (-140) and obtains calibrated true altitude (15,340 - 140 = 15,200).

2. To calibrated true altitude (15,200) he applies pressure correction (-390) and obtains pressure altitude (15,200 - 390 = 14,810), which is the first requirement.

3. In the altitude correction window of his computer, he places pressure altitude (14,810 or approximately 14,800) under the temperature (+10°C). The computer then is set up and he locates calibrated true altitude (15,200) on the movable (minutes) scale and opposite it, on the stationary (miles) scale, he reads corrected true altitude (16,650), which is the second requirement.



INDICATED ALTITUDE



CALIBRATED ALTITUDE



TRUE ALTITUDE

The complete problem may be set up as follows:

INDICATED TRUE ALTITUDE	SCALE ERROR CORRECTION	CALIBRATED TRUE ALTITUDE	PRESSURE CORRECTION	PRESSURE ALTITUDE	TEMP	CORRECTED TRUE ALTITUDE
<i>15,340</i>	<i>-140</i>	<i>15,200</i>	<i>-390</i>	<i>14,810</i>	<i>+10°C</i>	<i>16,650</i>

To obtain the corrected absolute altitude, the navigator has only to subtract the surveyed elevation of the terrain over which he is flying (obtained from the Sectional or other chart) from the corrected true altitude.

AIRSPEED

The fundamental formulas involved in the relationship of time, speed, and distance already have been presented. The student has seen that time is measured in hours, minutes, and seconds by means of the watch, clock, or chronometer; and that for purposes of navigation distance is measured in nautical miles on a chart or on the surface of the earth. It has been pointed out that speed is measured in knots, miles per hour, or kilometers per hour and that when any two of the three values of time, speed, and distance are known, the third may be determined quickly.

It is well to note at this point that the navigator deals with two types of speed, (1) airspeed (AS) and (2) groundspeed (GS). Groundspeed will be defined later in the discussion.



Airspeed is defined as the speed of the aircraft in relation to the body of air in which it is moving. It must be remembered that this body of air may itself be moving, and in practically every case, is moving, but airspeed is not concerned with that movement. By way of illustration, it may be assumed that a group of men are marching at a constant rate on the deck of an ocean liner. Their progress over the deck will be constant

in relation to the deck surface, in whatever direction they march, regardless of whether or not the liner itself may be moving while they are marching. If the ship were moving at the rate of ten miles per hour, the group could start at one edge and march to the opposite edge in exactly the same time that it would take if the vessel were standing still, since their speed of marching would be in relation to the deck surface only. In a like manner, an aircraft flies through the air at a certain airspeed, that is, speed with relation to the body of air, and this airspeed is unaffected by whether or not the body of air itself is moving.

Airspeed is measured by an instrument called the *airspeed meter*. The simple airspeed meter consists of two major parts, (1) a pitot-static tube and (2) the meter or indicating unit.

The working of the airspeed meter may be understood by examining the diagram of a simplified airspeed meter. Static pressure of the air (pressure of the air unaffected by the forward motion of the aircraft) enters the holes on the sides of the pitot-static tube and is carried to the sealed meter, with the result that the pressure in the meter always is equal to the normal outside air pressure. Dynamic pressure of the air (pressure caused by the forward motion of the aircraft) enters the mouth of the pitot-static tube and is carried to the inside of an aneroid cell within the meter. One side of the aneroid cell is fixed; the other is free to move. To the free side of the aneroid cell is affixed a pivoted pointer that moves over a dial face as the aneroid cell contracts or expands.

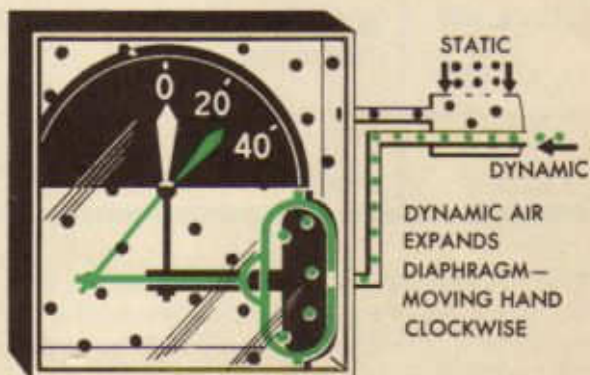

HOW AIRSPEED METER WORKS

When the aircraft is not in motion with relation to the air, the pressure in the aneroid cell is the same as that in the meter, so the needle remains at zero. When the aircraft is in forward motion with relation to the body of air, however, the dynamic pressure in the aneroid cell becomes greater than the static pressure in the meter and causes the cell to expand, thus moving the pointer over the face of the dial. On the dial is a scale, usually in *miles per hour*, which indicates the airspeed of the aircraft.

The pitot-static tube must be mounted on the aircraft exactly parallel, both vertically and horizontally, with the longitudinal axis of the aircraft and in some place so as not to be affected by the slip-stream of the aircraft or the back-wash of the propellers. It usually is mounted, therefore, far out on the leading edge of the wing of single-engine aircraft and well out on the nose of multi-engine aircraft.



PITOT TUBE PARALLELED TO LONGITUDINAL AXIS AND OUT OF SLIPSTREAM

There are three steps in the measurement of airspeed. (1) Read *indicated airspeed*, usually in *miles per hour*, from the dial face of the airspeed meter. (2) By means of the *calibration card* hanging near the instrument, correct the indicated airspeed for instrument error and convert miles per hour into knots, getting *calibrated airspeed*. (3) By means of the computer, correct calibrated airspeed for density error. This is done in



INDICATED AIRSPEED



+

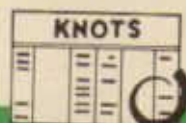

CALIBRATED AIRSPEED



+



TEMP.
PRESS.

TRUE AIRSPEED

two steps. (1) Set up the computer for the correction of airspeed by setting *pressure altitude* against *free air temperature* at the window on the slide rule face of the computer captioned "For Airspeed Corrections." (2) When the computer is set up, read *true* (corrected) *airspeed* on the stationary (miles) scale opposite calibrated airspeed on the movable (minutes) scale.

The navigator is interested not only in airspeed, but also in *groundspeed*. Groundspeed is the rate of motion (speed) of the aircraft over the surface of the earth. Groundspeed and airspeed are rarely equal, except under very particular circumstances.

For purposes of illustration, consider this problem. A boat is moving directly north at the rate of 4 knots on a body of water that is

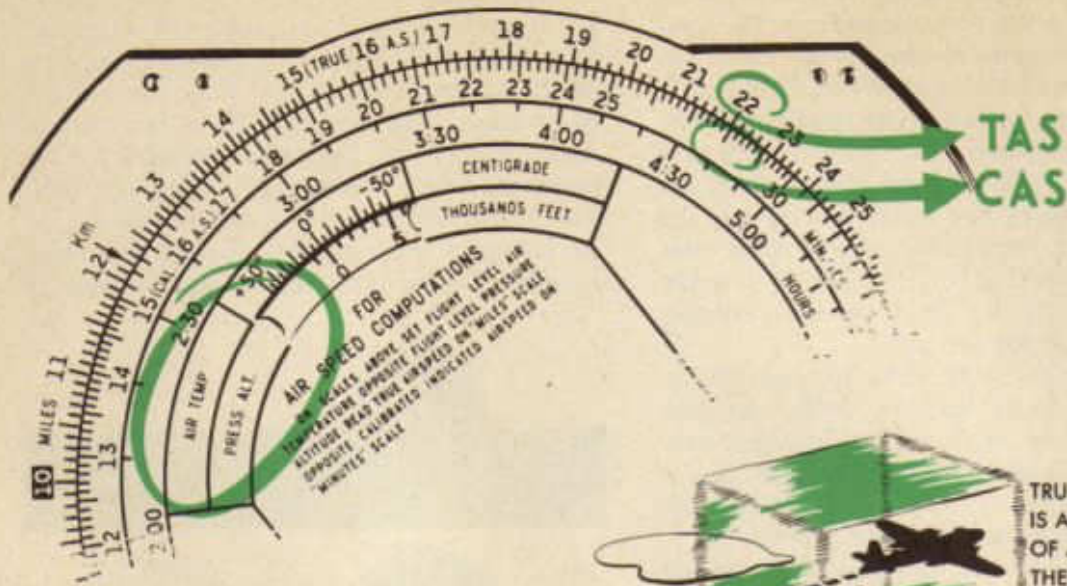

moving directly east at the rate of 2 knots. At the end of one hour, the boat will be at a point 4 NM north and 2 NM east of the starting point. The groundspeed of the boat for the hour would be the distance from the

starting point to the position at the end of the hour. This speed is called the resultant of the two speeds, (1) speed of the boat and (2) speed of the body of water. In a like manner, the groundspeed of an aircraft is always the resultant of (1) the true airspeed of the aircraft and (2) the speed of the body of air in which the aircraft flies. Considerable attention will be given later to the determination of groundspeed.

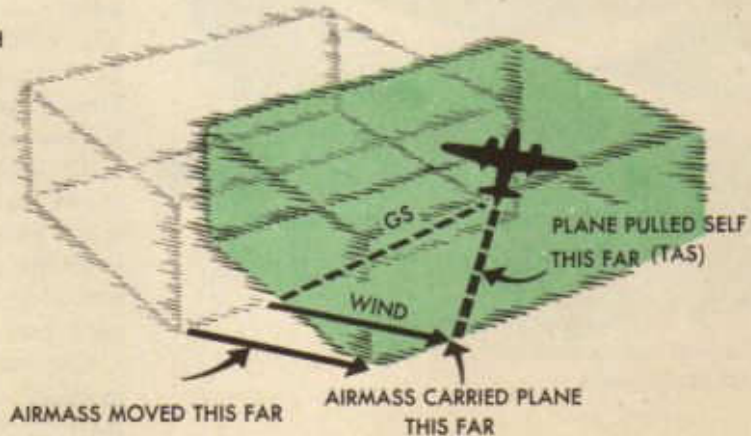
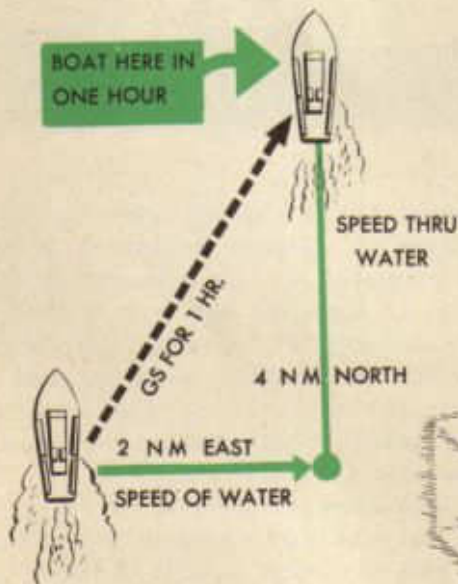

18 also WEEM # 112-119

EFFECT OF THE WIND

Up to this point, it has been assumed that an aircraft actually will go in the direction it is headed. This is an understandable assumption, since practically all moving vehicles with which men work do go in the direction they are headed. When the longitudinal axis of a moving car or wagon or cultivator is pointed north, the vehicle goes north. So generally is this fact observed that men unconsciously assume that a moving aircraft, too, moves in the direction it is pointed or headed. The fact is, however, that an aircraft very seldom moves in the direction it is headed. How could such a statement be true?

Two forces operate to determine the direction that an aircraft actually goes in flight, namely, the forward pull of the engines and the effect of the wind. The forward pull of the engines, transmitted through the propeller, always is in the direction of the longitudinal axis of the aircraft. What about the effect of the wind?

First, what is a wind? A wind is a mass of air moving in a horizontal direction. Two things are observed about the wind: it may come from any direction and it varies in strength or force. Navigators indicate the direction of the wind in terms of degrees *from which the wind comes*. They refer to the wind ordinarily known as the west wind as a wind *from* 270°. Navigators measure the strength or force of the wind in knots. For instance, they say that a wind has a force of 20 knots or is a 20-knot wind when the mass of air is moving at the rate of 20 knots. Meteorologists, however, measure the force of the wind in statute miles per hour and they refer to a wind of 20 knots as a wind of *23 miles per hour* or *23 mph*. The navigator must be careful to convert the meteorologist's miles per hour into knots. This conversion may be done on the computer or by formula.

Navigators refer to a wind from 270° having a force of 20 knots as "270°/20 kts." This statement of wind direction and force (W/D & W/F) is known as *wind velocity* (W/v). Therefore, when navigators refer to a "wind velocity of 270°/20 kts.," they mean a wind from 270° having a force of 20 knots.

Consider now the effect of the wind upon free objects in the air. By free objects is

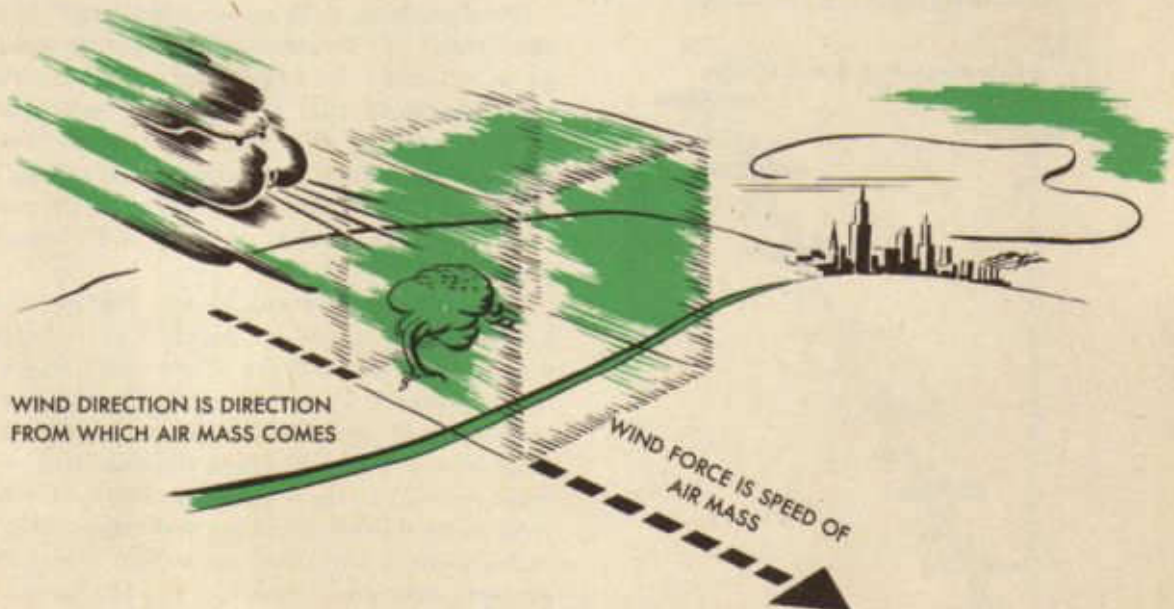

WIND IS HORIZONTAL MOVEMENT
OF AN AIR MASS

meant objects not fixed and therefore free to move unhindered. A balloon is such an object; an aircraft is another. If a balloon is visualized as being at point A at 0900 afloat in a mass of air moving from 270° at the rate of 20 knots (W/v : 270°20K), where will the balloon be at 1000? The mass of air in which the balloon is floating will have moved 20 nautical miles from 270° and toward 090° during the hour. Will not the balloon move along with the mass of air to a point 20 nautical miles from point A in the direction in which the air is moving? This movement will put the balloon at 1000 at point B, a position 20 nautical miles from point A in the direction of 090°

FREE OBJECT MOVES
DOWNWIND AT A SPEED EQUAL
TO THE WIND FORCE

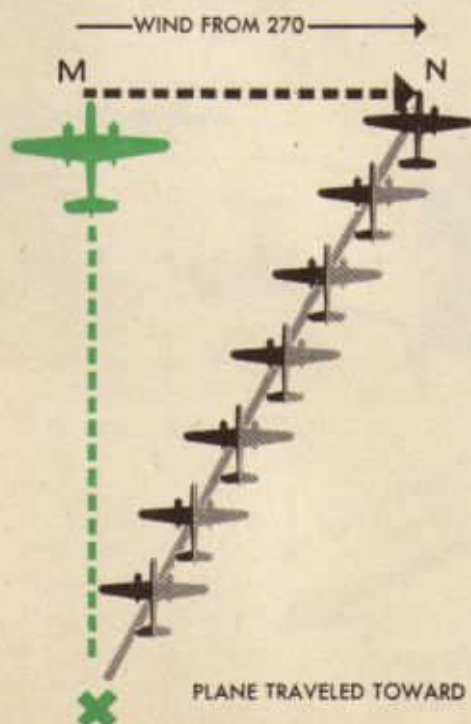
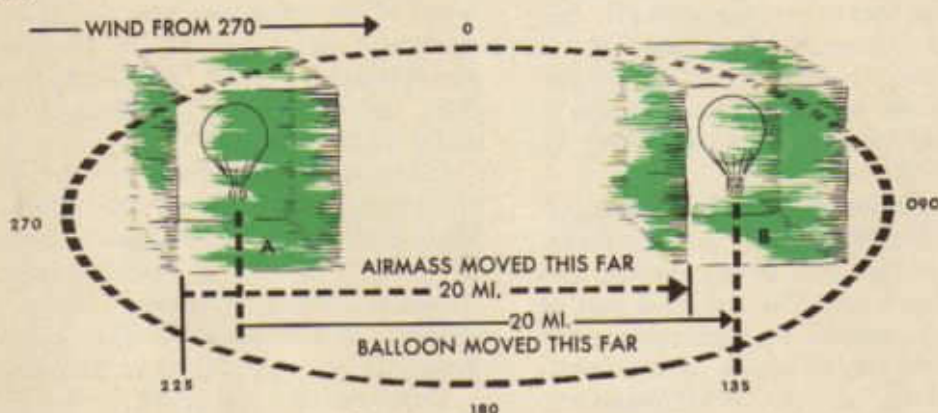

This position, B, is called a position "down the wind," or "downwind." It may be stated as a principle to remember when dealing with the wind that free objects in the air move downwind at a rate equal to the force of the wind. Thus the balloon will move, in the hour 0900-1000, a distance of 20 nautical miles downwind, or from 270° toward 090°.

The principle set out above, namely, that a free object in the air moves downwind at a rate equal to the force of the wind, applies to an aircraft in flight in exactly the same manner as it applies to a balloon. An aircraft aloft in a wind of 20 knots for one hour will have moved, at the end of the hour, 20 nautical miles downwind. *This movement will be in addition to any other movement which the aircraft may have made during the hour.*

For example, an aircraft departs from point X on a heading of 360° in a wind of $270^\circ/20K$ and flies for one hour. The heading is represented by the green line XM. Were there no wind, the aircraft one hour later would be at point M, directly north (360°) of X. There is a wind, however; the aircraft, therefore, has been aloft for one hour in a moving mass of air. In the hour the aircraft has been aloft, the mass of air in which it has been flying has itself moved 20 nautical miles from 270° toward 090° . The aircraft has moved with it. When the aircraft has flown an hour, therefore, it is not at point M, but it is at a point N, 20 nautical miles downwind from M. The grey line XN represents the actual track of the aircraft over the ground during the hour. The broken line MN shows the 20 nautical miles which is the effect of the wind. Note particularly that the aircraft has not at any time during the hour had its nose pointing toward N. It has been heading 360° all the time. The angular difference between the green line, the heading of the aircraft, and the grey line, the actual track of the aircraft, is called *drift*, and the angle MXN formed by the two lines is called the *drift angle*. In this example, the drift has been to the right and is called

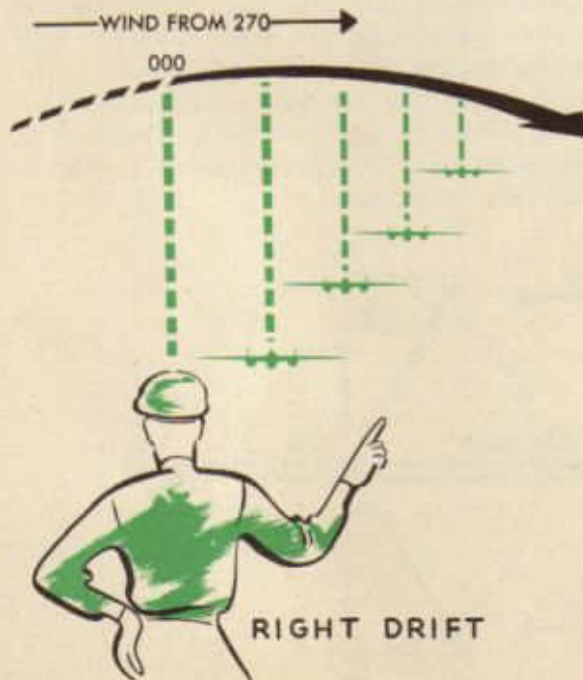

“right drift.” When the drift is to the left of the heading, it is called “left drift.”

The figure following shows by lines the effect of a $270^\circ/20K$ wind upon an aircraft on various headings. In each case the aircraft takes off from point X and flies for one hour. The green lines represent the heading of the aircraft or the direction it would go if there were no wind. The length of the green lines represents the distance the aircraft would go in one hour were there no wind. Since speed is indicated in terms of how far an aircraft goes in one hour, then the green lines represent the speed of the aircraft in still air or true air speed (TAS).

Note that when the aircraft is flying into the wind the black line is shorter than the green; when the aircraft is flying downwind the black line is longer than the green.

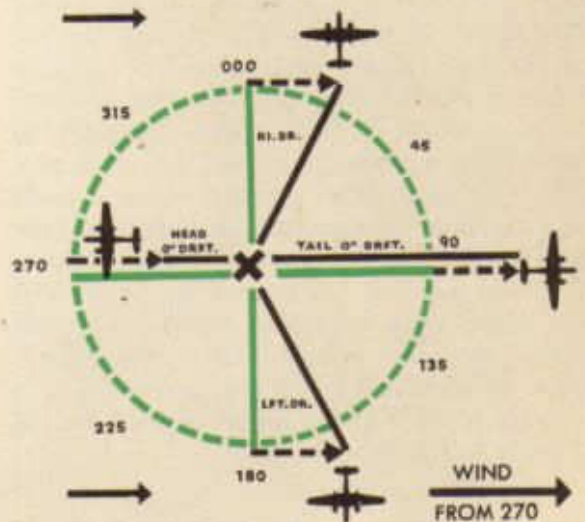

Thus far the discussion has been confined to a consideration of what happens when an aircraft flies a certain heading in a wind. Another factor comes up now. Suppose an aircraft is at point X and wants to fly to point A, 360° from X, in a $270^\circ/20K$ wind. What heading must it fly to arrive at A? Obviously, it should not head 360° . If it did, it would arrive at a point 20 nautical miles downwind from A. Might it not head to some point upwind from A and let the drift bring it in to A? If the aircraft is going to be in the air one hour and is going to drift 20 nautical miles during that hour, should it not

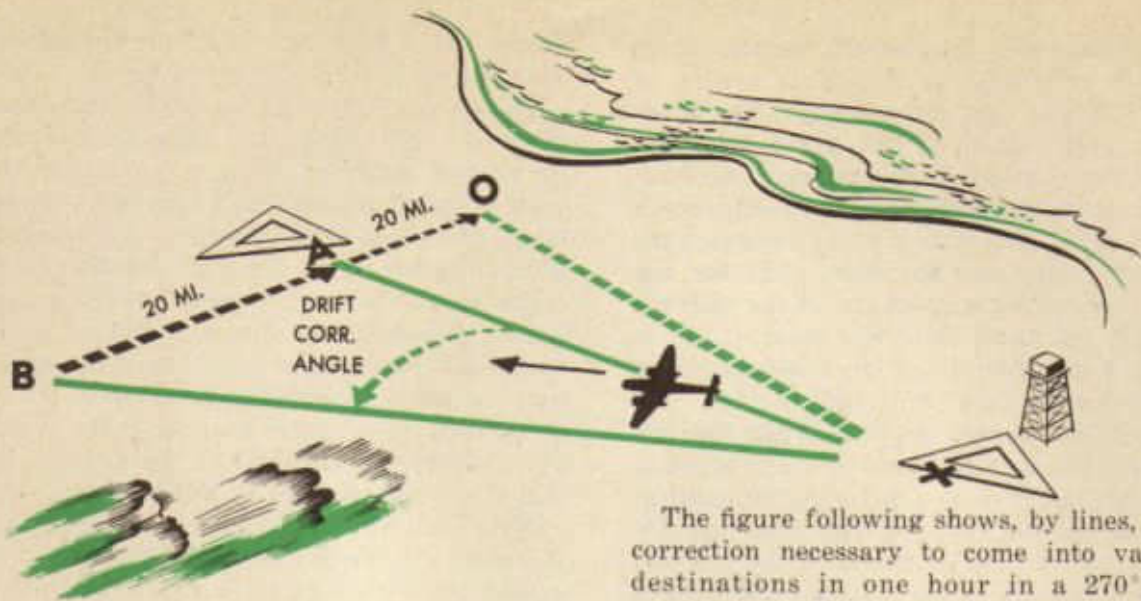

head for a point 20 nautical miles upwind from point A, say point B? Then, at the end of the hour, it will have drifted 20 nautical miles downwind from point B and thus will arrive at point A. It will head, therefore, in the direction of the green line XB. This procedure of heading an aircraft at some point upwind from destination in order to take care of drift, or in order to "drift in" to destination, is called "correcting for drift" and the angle BXA is called "drift correction angle" or, more simply, "drift correction." Drift correction is called plus correction if it is made to the right or minus correction if it is made to the left

The figure following shows, by lines, drift correction necessary to come into various destinations in one hour in a 270°/20K wind. The black lines are drawn from departure point X to the various desired destinations. They represent, therefore, the desired course. In each case, the effect of the wind for one hour, 20 nautical miles, is drawn *upwind* from destination. The green lines represent true heading or heading necessary to come into destination. Remember that the length of the green lines represents the TAS necessary for the plane to make in order to make the groundspeed indicated on the black line. Note then that the black lines (true course) always are drawn directly from departure point to destination. Note that the broken lines, wind, are drawn upwind, with the downwind end always at destination. The green lines, true heading, are always drawn from departure point to the upwind end of the wind line. This arrangement is simple, but very important.

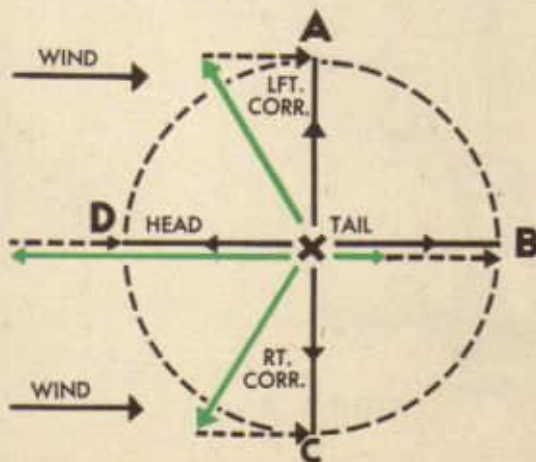
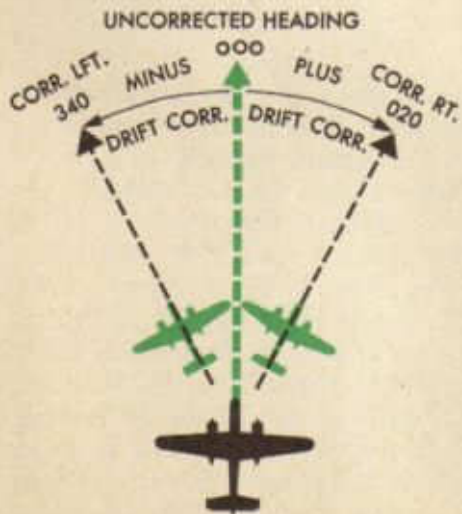

The *driftmeter* is an instrument for determining drift correction. It is, therefore, one of the most important of the navigator's instruments. It determines drift correction by comparing the true heading of the aircraft and the actual path the aircraft is making good over the ground.

Consider a very crude driftmeter. The navigator cuts a round hole in the floor of the aircraft so that he can see objects on the ground. Across this hole he stretches a thin wire XY which is parallel to the longitudinal

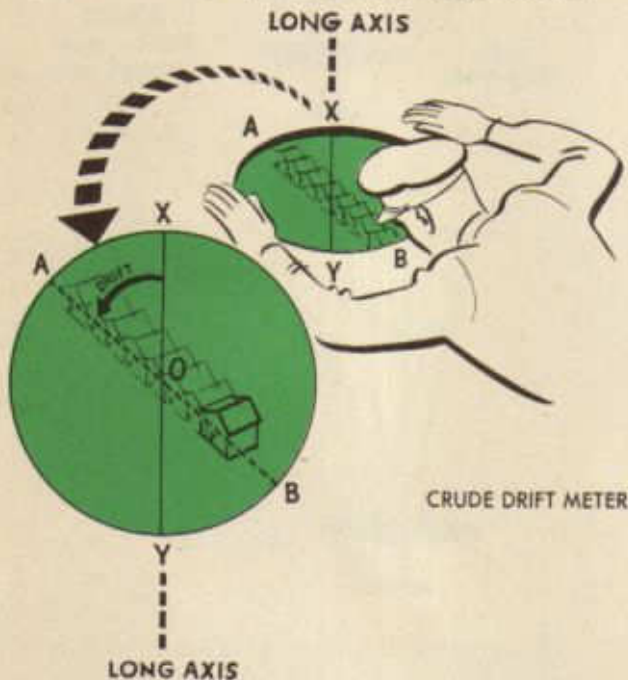

axis of the aircraft. This wire will represent the true heading of the aircraft at all times. Such an arrangement might look like the figure above. In flight, a house on the ground might appear to be going across the hole in the manner indicated by the line AB. The house, of course, is standing still; its apparent movement results from the actual movement of the aircraft in the opposite direction. This arrangement, then, makes possible a comparison of the true heading of the aircraft represented by the wire XY, and the track the aircraft is making over the ground, represented by the line AB. The angle AOX, which the path of house (AB) makes with the longitudinal axis of the aircraft (XY), is the drift angle. The drift indicated in the drawing is left drift. The drift correction, therefore, is a plus angle of the same size.

With the arrangement shown, the navigator can only guess at the size of the angle. But he requires accuracy greater than a mere guess. In searching for this accuracy, he might evolve an arrangement somewhat like the figure below.

This arrangement consists merely of a circular piece of glass mounted over the hole in the bottom of the aircraft. On the glass is drawn a series of parallel lines called grid lines or grid wires, the center one being extended to the edge of the glass and used as a

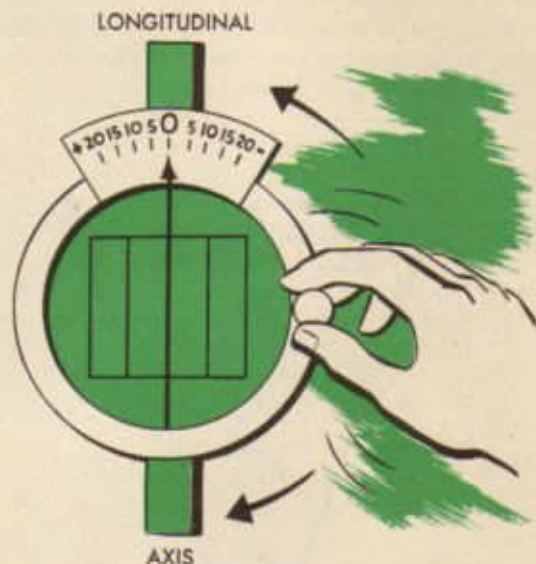

pointer. The glass is movable and may be turned by a handle at the side. On the floor, just ahead of the hole in the floor, a scale of degrees is drawn, zero being so placed that when the arrow on the glass is parallel to the longitudinal axis of the aircraft (represented by the wire AB), it points to zero. He puts a plus to the left of the zero and a minus to the right.

With this arrangement, the navigator looks through the glass at objects on the ground. The objects seem to be moving across the glass. The navigator rotates the glass until the objects appear to be moving across the glass exactly parallel to the parallel lines. He then looks at the pointer and reads from it, for example, $+15^\circ$. The arrangement then appears somewhat like the figure following.

The navigator knows then that he must correct his course $+15^\circ$. Why is this true?

The longitudinal axis of the aircraft is represented by the broken line or by the wire AB. The path of the aircraft is represented by the

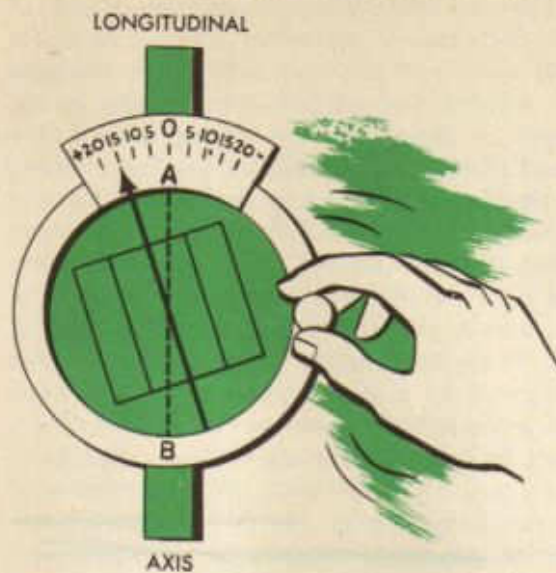

the pointer. The angle between the broken line and the arrow measures drift. In the example above, the drift, measured on the scale at the edge of the glass is seen to be 15° left drift; therefore, the drift correction will be plus 15° as is indicated on the scale. Therefore, the navigator must add 15° to the course he is flying in order to get a true heading which will enable him to make good that course.

With an arrangement such as has been described, the navigator has the essentials of a modern driftmeter. In the modern driftmeter, the plate with the parallel grid wires has been placed in a tube extending from eye-level through the floor of the plane; the pointer is on the outside of the tube. The effect, however, is exactly the same.

Consider the construction of the modern driftmeter. There are certain movable parts. These are in or on the tube mentioned above which extends from eye-level through the floor of the plane. In this tube the grid-wires are placed. In the B-2 army driftmeter, the grid wires are merely painted on the glass; in the B-3, the grid wires are painted on with a type of paint that glows when a light shines on it. In order that the navigator may see objects on the ground more clearly, a telescopic eyepiece is placed on the upper end of the tube. This eyepiece is equipped with

a low-power lens for ordinary flights and a high-power lens for high altitude flights. If nothing is placed in the bottom of the driftmeter, the navigator can see straight down only. Some of the older instruments are arranged this way, but the present day driftmeters have mirrors or prisms mounted in the bottom of the tube so that the navigator

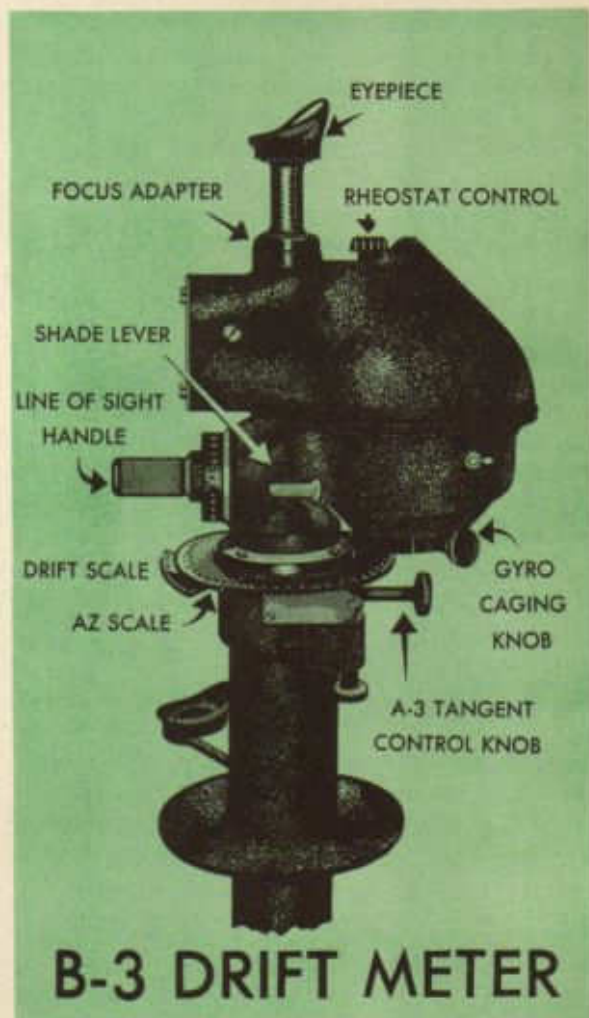

can see ahead, behind, or to either side, as well as straight down. This arrangement makes the navigator's field of vision or "line of sight" considerably larger. Two handles, for turning the tube, are conveniently placed; and one handle, called the "line of sight" handle, may be twisted to turn the "line of sight" prism in the bottom of the tube. This turning of the prism enables the navigator to

see 15° toward the front and 85° toward the back of the driftmeter. By turning the driftmeter, he may see 85° in any direction from the aircraft. A pointer is attached to the outside of the tube parallel to the grid wires.

In addition to the movable parts, the driftmeter has certain stationary parts. The tube must be mounted in the aircraft so that it will turn; therefore, there is a mounting and a collar for the tube. On the mounting, snug around the tube, is a circle divided into 360°, called an *azimuth ring*. The zero on the azimuth ring is mounted toward the rear and on the longitudinal axis of the aircraft, while the 180° is toward the front and is also on the longitudinal axis. The azimuth scale is for measuring relative bearings, a topic to



be considered later. Of concern now is the *drift correction scale*, mounted toward the front in such a manner that when the grid wires in the tube are parallel to the longitudinal axis of the aircraft, the pointer on the outside of the tube points to zero on the

POINTER SHOWS
DIRECTION
YOU ARE LOOKING

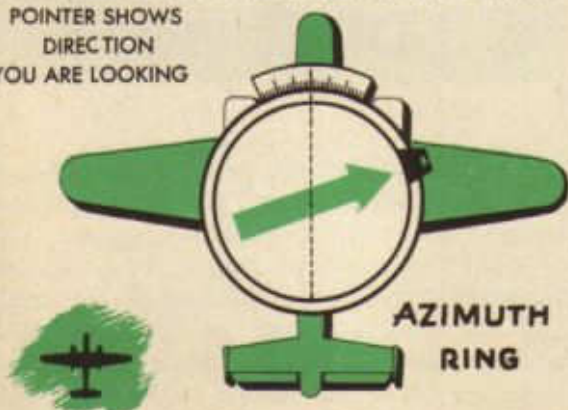

drift correction scale. The scale reads from 0 to 20 in either direction; a plus is on the left and a minus is on the right of zero.

Certain refinements have been made in the instrument described above. A worm gear and drive has been attached to the tube for making fine adjustments. It may be engaged or disengaged readily by means of a small clutch. A shade glass has been placed in the tube in such a way that it may be used to cut out glare or moved out of the way when it is not needed. A heavy cover glass has been put over the bottom end of the tube to protect the instrument from dust, rain, etc. Some driftmeters have the grid wires stabilized by a gyro arrangement. The gyro is a delicate and expensive instrument which must be used exactly according to directions and cared for very carefully. Two rules may be mentioned here. (1) ~~Never use a gyro driftmeter except in straight, level flight;~~ (2) ~~keep the gyro caged at all times except when actually using the driftmeter.~~ The gyro is caged or uncaged by moving a small lever on the instrument to the positions marked "caged" or "uncaged." Remember that the gyro driftmeter should be used only after the gyro has been uncaged for one minute on straight, level flight.

Army aircraft are equipped with one or more of three types of driftmeter, either the B-2, the B-3 or the B-5. The B-2 driftmeter has no gyro and the grid wires are not luminous; the B-3 has the gyro and the luminous grid wires. The B-3 grid wires are lighted by a small bulb in the top of the instrument. If the bulb burns out and another is not available, the wires may be lighted by shining a flash light through the hole from which the bulb is removed, or, if no flash light is available, the instrument can be used without a light in daytime.

The B-2 and B-3 driftmeters described above are used in exactly the same manner as was the glass plate in the floor of the aircraft. The navigator looks through the tube and turns it until the grid wires are parallel with the apparent motion of objects on the ground. He then reads drift correction on the drift correction scale opposite the pointer. In case the correction is more than 20°, he can count the extra degrees on the azimuth ring.

UNTRUE

The B-5 driftmeter, found in some army aircraft, differs considerably from the B-2 and B-3, both in construction and in use. In the B-5, an image of the ground beneath the aircraft is seen when the navigator looks through the eyepiece. By the side of the eyepiece is fixed a circular piece of frosted glass and on top of the glass, in a vertical position, is a pencil. If the navigator moves the pencil, he sees that it is connected, by a pantograph

B-5 DRIFT METER



mechanism, to a pointer that he sees when looking through the eyepiece. Thus, if he makes the pointer follow an object on the ground, he makes a line on the frosted glass with the pencil; the line is really a record of the track of the aircraft.

Underneath the frosted glass plate is a circular grid card, bearing a number of parallel lines, which are clearly seen through the glass plate. This grid card may be rotated to make the direction of the parallel lines as nearly as possible parallel to the average direction of the recorded track or tracks. The angular movement of the grid card from its zero drift position measures the drift angle; the amount of drift correction is read against a pointer fixed to the grid card.

The field of view of the instrument is about 38 degrees, and this allows drift measurements with practice, down to about 800 feet at 150K. The central line of view is inclined 15 degrees to the vertical in a plane at right angles to the fore and aft axis of the aircraft.

Rotation of the grid card is transmitted by means of linkage to one of the lenses, on whose surface is engraved a graticule, so that the grid card and the graticule rotate together. The graticule consists of four parallel grid lines which always remain parallel to the lines on the grid card and two ground-

PENCIL REPRODUCES
TRACK

speed timing lines at right angles to the grid lines. The groundspeed timing lines converge slightly to allow for the perspective effect due to the oblique view of the ground given the instrument.

The grid lines on the lens will not be used, generally, to measure drift, but they can be used in cases where objects move too fast to be followed by the pointer, e. g., at low heights, or in the event of damage to the mechanism. Drift read in this manner, however, is not very accurate and should not be trusted very much.

The instrument may be supported on brackets and if so, is retractable. It may be withdrawn to protect the projecting end from sea-spray or dirt when landing or taking off, to avoid wind resistance when it is not in use for a long time, or to enable the outer mirror or lens to be cleaned in cases of misting or icing which do not quickly disappear.

The eye end of the instrument, with the pantograph and the pencil, is hinged and may be raised fully when it is necessary to wipe the field lens and the graticule. Care must be taken not to foul the pointer during

this operation. The pencil marks are easily removed with a damp rag. Rubber erasers should not be used because the resulting small fragments of rubber tend to clog the instrument.

To operate the B-5 driftmeter:

1. Move the pencil to draw a track on the glass plate, so that the pointer follows the movement of an object on the ground across the field of view of the instrument. Repeat with other objects; two or three tracks should suffice in fairly steady conditions and at heights above 2,000 feet. At lower heights and in bumpy weather, more tracks will be required.

NAVIGATOR SEES THIS THRU EYEPIECE

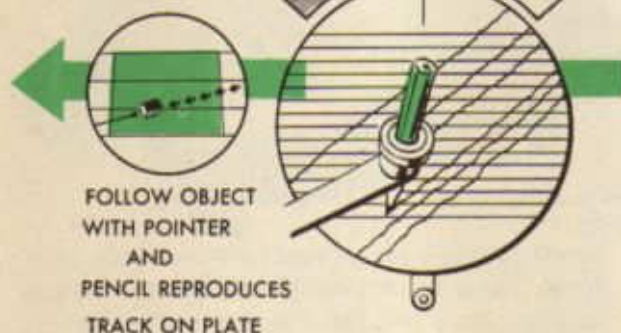

Drift tracks should be distributed on both sides of the center to avoid the slight error which would arise if the tracks were mainly on one side of the center. If the field on one side of the center is greatly restricted by the hull of the aircraft, use tracks as close as possible to the center.

2. Push pencil holder over clip provided adjacent to the eye-piece and bring the grid card into alignment with the average direction of the recorded tracks

3. Read off the drift correction if using Eastman model, or drift, if using English model, on the scale.

4. At night, the pointer will be seen sil-

houetted against the ground if any ground contours can be distinguished. For use with ground lights which may come within the field of view, the end of the pointer is made luminous.

The following hints have been found to be useful to a navigator using the B-5 driftmeter:

1. When flying over broken cloud, record the tracks of any objects as soon as they become visible until a number of portions of tracks have been recorded. Remember that the tracks are all taken on different objects, and therefore the grid card lines should not be placed so as to join any two of them. The best method is to align the grid with each portion of track in turn and take the average of the drifts indicated.

2. When flying over territory devoid of well defined objects or over calm sea, track records can be obtained by moving the pointer so that it remains stationary relative to the texture or color variations of the ground or sea.

3. To withdraw the driftmeter, lift inner edges and withdraw.

4. If a new pencil is required, a three-inch length of hard pencil (about 2H) should be used. It should be inserted in the holder so that the point is on the left-hand side of the recording plate, and locked with the set screw.

5. BEFORE TAKING DRIFT ALWAYS WARN PILOT THAT YOU ARE ABOUT TO BEGIN SO THAT HE WILL CONCENTRATE ON MAINTAINING A CONSTANT COURSE AND AIRSPEED. INFORM PILOT WHEN YOU HAVE FINISHED.

6. Before using the instrument, check to see whether it reads drift angle or drift correction. British manufactured instruments read drift angle and the sign must be reversed to get drift correction.

In addition to determining drift correction, the driftmeter is used for several other purposes. Groundspeed may be determined fairly accurately by either of several methods, some of which will be explained at the proper time later in the course. The B-2 or B-3 driftmeter may be used also to determine relative bearings, which use will be explained later also.

PRECISION DEAD-RECKONING CHARTS

Mercator Chart

Navigation charts are separated into two main classes:

1. Topographic or descriptive charts. These charts are used chiefly for map-reading. Those most widely used by the American Air Forces are sectional, regional, and D. F. charts, all Lambert Conformal charts.

2. Plotting charts. These charts are used for laying off the flight route and for plotting the flight as it is made. The kind of plotting chart with which the navigator is concerned at present is the Mercator projection.

It was noted in the study of the Lambert projection that no single chart fills all the requirements for an ideal chart; therefore, several types of charts are in use, the type used at any particular time depending upon the requirements of the navigator at the time.

As a general rule the navigator finds it more convenient to follow a rhumb line course over the earth than to save a few miles distance by following a great circle track. Consider a flight from Hondo, Texas, Army Air Field to a point 500 miles to the east at the same latitude. The great circle

track measures 083° at first, but it changes rapidly at the rate of 1° every 35 nautical miles until the true course is finally 097° . The rhumb line course would be along the parallel, that is, 090° for the whole journey, and it would be only about one mile longer. Generally speaking, the saving in distance by following great circle courses in flights up to 500 miles is not worth the additional trouble involved.

It obviously is a great help if a rhumb line can be laid down on a map by simply drawing a straight line. If this is to be done, all meridians must be parallel, since a rhumb line cuts meridians at the same angle. This arrangement of the meridians would provide one of the navigator's requirements.

The second navigational requirement is that angles anywhere on the earth's surface shall be correctly represented on the map. The equator and all parallels of latitude cut all meridians at right angles on the earth; therefore, they must cut all meridians at right angles on the projection.

Thus, the map takes the pictured form in order to satisfy these two requirements.

However, the parallels of latitude have

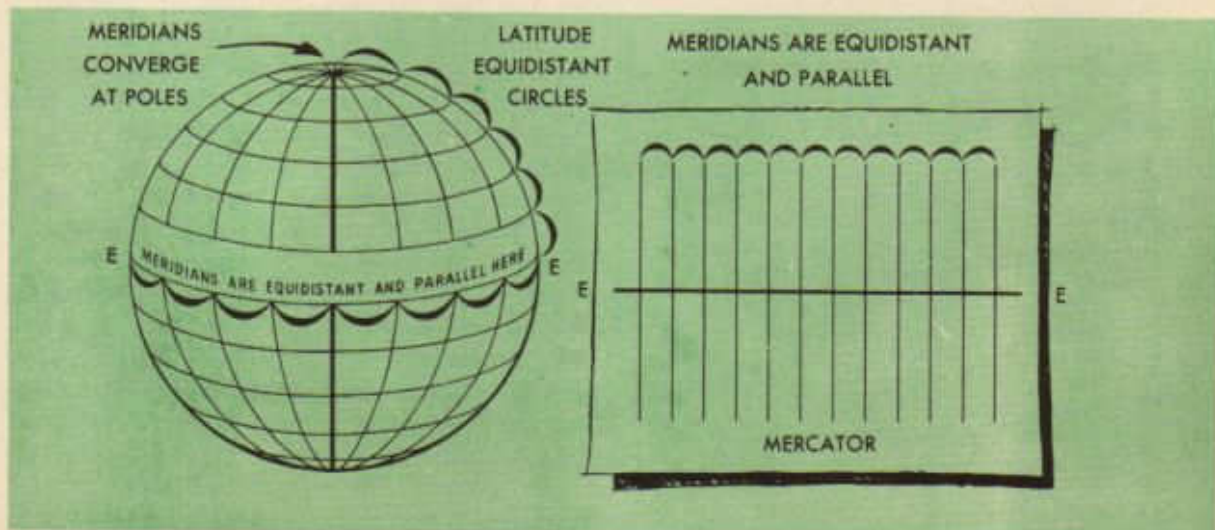

not been included because their vertical spacing has not been decided. A glance at any globe reveals that parallels of latitude are evenly spaced, but it will also reveal that meridians, while apparently parallel at the equator, converge at the poles. The meridians in the skeleton map above do not converge; therefore, considerable distortion results as the distance from the equator increases. This distortion can be visualized by imagining a strip cut out of a hollow rubber ball between two meridians wide apart. The strip could be placed on a flat surface by stretching the rubber between the meridians more and more as the distance from the

equator increased. In order to make it perfectly flat, the rubber would have to be stretched enough for the meridians to take the shape of straight lines perpendicular to the equator. If this stretching took place, the parallels of latitude could be stretched straight between the meridians, and they would appear as straight lines at right angles to the meridians. However, since the proper relationship between meridians and parallels must be maintained, the distance between parallels of latitude must be increased in the same proportion as the distance between meridians is increased. In other words, the rubber must be stretched

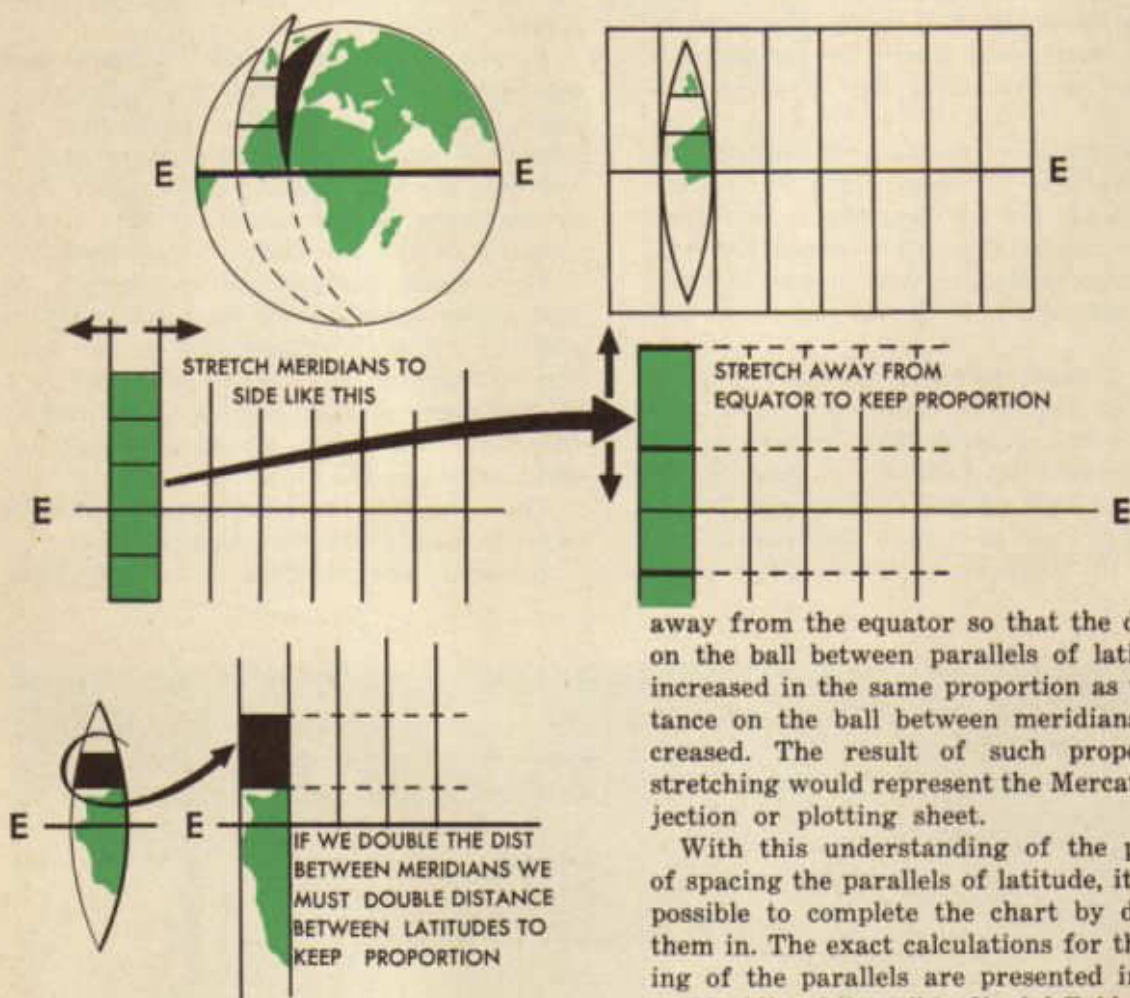

away from the equator so that the distance on the ball between parallels of latitude is increased in the same proportion as the distance on the ball between meridians is increased. The result of such proportional stretching would represent the Mercator projection or plotting sheet.

With this understanding of the problem of spacing the parallels of latitude, it is now possible to complete the chart by drawing them in. The exact calculations for the spacing of the parallels are presented in Table 5 "Meridional Parts" in *Useful Tables*, H. O. No. 9, Part II. Meridional parts are the number of times the length of one minute of longitude on the Mercator chart is contained in the distance between the equator and any particular parallel of latitude.

Thus, if the length of 1' of longitude on a certain Mercator chart is 0.02 inch, the distance between the equator and parallel 20°N on that chart is:

$$\begin{aligned} &0.02'' \times \text{Meridional parts for } 20^\circ \\ &(\text{found in Table 5 to be } 1217.1.) \\ &= 0.02 \times 1217.1 \text{ meridional parts} \\ &= 24.342 \text{ inches} \end{aligned}$$

When the equator is not included on the proposed projection, a principal parallel must be selected as a reference point. The distance of any other parallel of latitude from the principal parallel is then the difference of the meridional parts for the two taken from the tables and reduced to the scale of the chart.

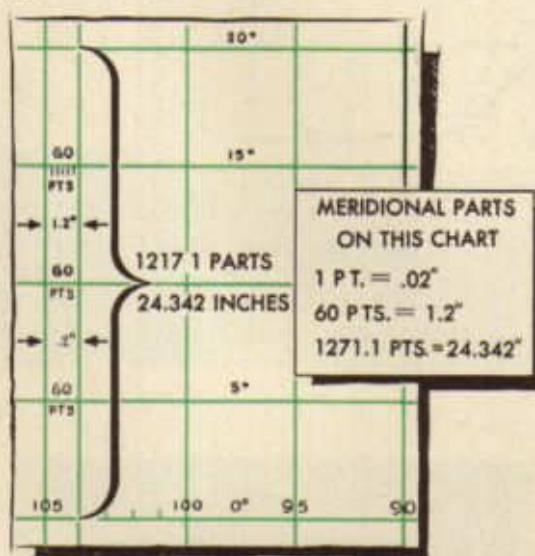

Graphical construction of a Mercator chart is accurate enough for navigation and is probably the most practical. It is based on the assumption that the earth is a true sphere, in which case the meridians are true circles. While this assumption is not exactly true, for a small area the resulting error may be disregarded.

In order to construct a Mercator chart graphically, decide on the scale and lay off the meridians accordingly, being careful to erect them as perpendicular lines from a base line. Having decided upon the desired latitudes, name the base line, say 40°. The next desired parallel is 41°; therefore, it may be approximated closely by laying off line AB so that angle BAC equals the mean latitude between parallels 40° and 41°, or 40°30'. Thus, the length of AB is the longitude scale

expanded in the ratio of the secant of the latitude. Lay off AD equal to AB along two meridians and draw the 41° parallel. Repeat, using mean latitudes, to determine the location of additional parallels.

Thus, a chart made on the Mercator projection has all meridians of longitude represented by parallel vertical lines and all parallels of latitude shown as parallel horizontal lines. The straight lines representing meridians and parallels cross each other at right angles. Although the longitude scale is constant by construction, the latitude scale increases as the distance from the equator becomes greater. This results in increasing distortion at higher latitudes. All Mercator charts are similar and when constructed on the same scale may be joined together. Although parallels of latitude are numbered, the meridians may be numbered as desired.

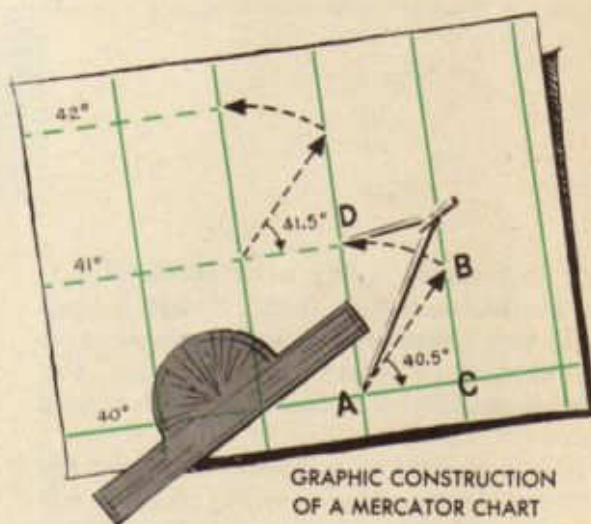

In numbering meridians it is imperative that the numbering be successive and conform to the direction of numbering on the earth's surface.

Among the advantages of the Mercator chart may be listed:

1. A rhumb line is a straight line
2. Positions are easily plotted
3. All charts are similar
4. The chart is easily constructed

The description of a Mercator chart indicates that it cannot be used to chart polar regions because the meridians meet at a point. It is impossible to stretch a point, which has no magnitude. The distortion is

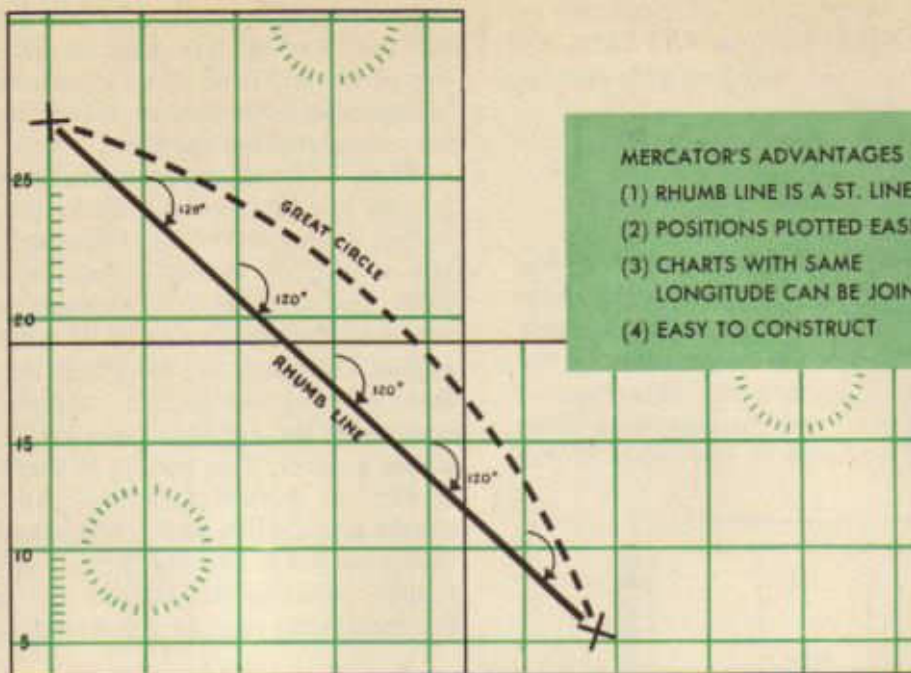

MERCATOR'S ADVANTAGES

- (1) RHUMB LINE IS A ST. LINE
- (2) POSITIONS PLOTTED EASILY
- (3) CHARTS WITH SAME LONGITUDE CAN BE JOINED
- (4) EASY TO CONSTRUCT

MERCATOR'S DISADVANTAGES

- (1) NOT SUITED ABOVE 60° LAT.
- (2) DISTANCE SCALE NOT CONSTANT
- (3) GREAT CIRCLE IS CURVED LINE

well illustrated in any atlas using Mercator projection, where India, though in fact about four times as large as Greenland, actually appears to be one-fourth as large. For this reason, Mercator charts are seldom used above 60° latitude.

It is important to remember also that the distance scale on the Mercator chart is not constant and that a great circle is a curved line.

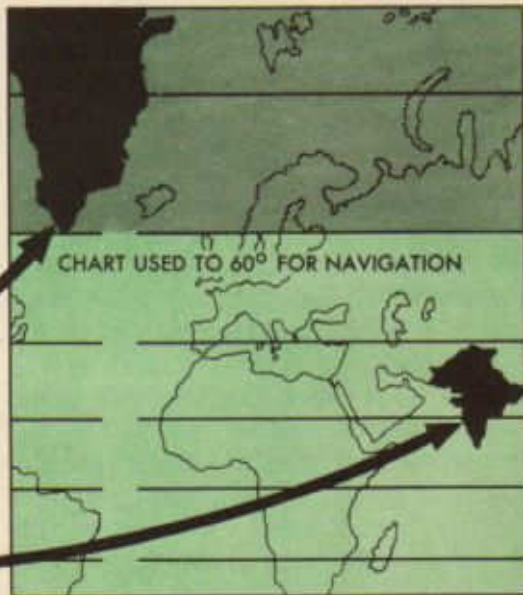

DISTORTION ON MERCATOR
 AREAS RETAIN CHARACTERISTIC SHAPE
 BUT NOT THEIR PROPORTIONATE SIZE

Use of Plotting Instruments On the Mercator Chart

The characteristics and construction of the Mercator chart have been discussed in detail. Now it is necessary to consider the techniques employed in the use of this chart.

The Mercator is one of the most widely used charts in aerial navigation. The Mercator properly used can tell just as complete a story of the flight as the log. On the other hand, poor plotting and careless use of this chart can be a great source of navigation error. It is essential, therefore, that all students master the techniques involved in the use of these plotting instruments so that errors in plotting can be held to a minimum and, after some practice, eliminated.

First, it is necessary to review briefly the important characteristics of the Mercator. Remember that the distance scale is not constant. This necessitates measurement of distances at the mid-latitude scale. Parallels of latitude are numbered at 30 minute intervals and marked off in units of one minute. The expanding latitude scale limits the use of the chart to the specific bands of latitude for which the chart was constructed. All Mercators are good for both the northern and southern hemisphere. To adapt any Mercator for use in the latter area merely invert the

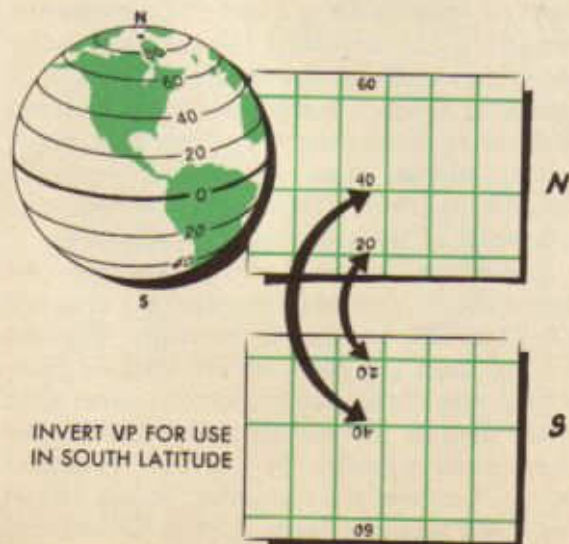
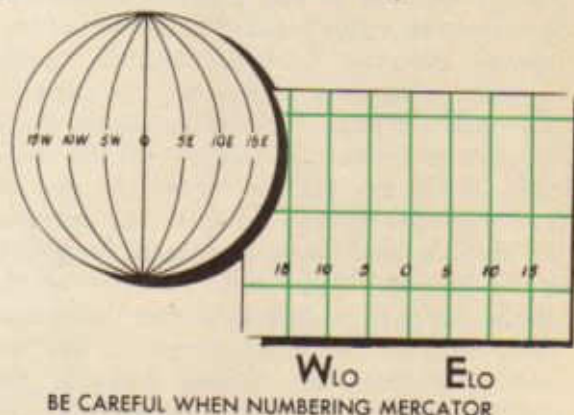
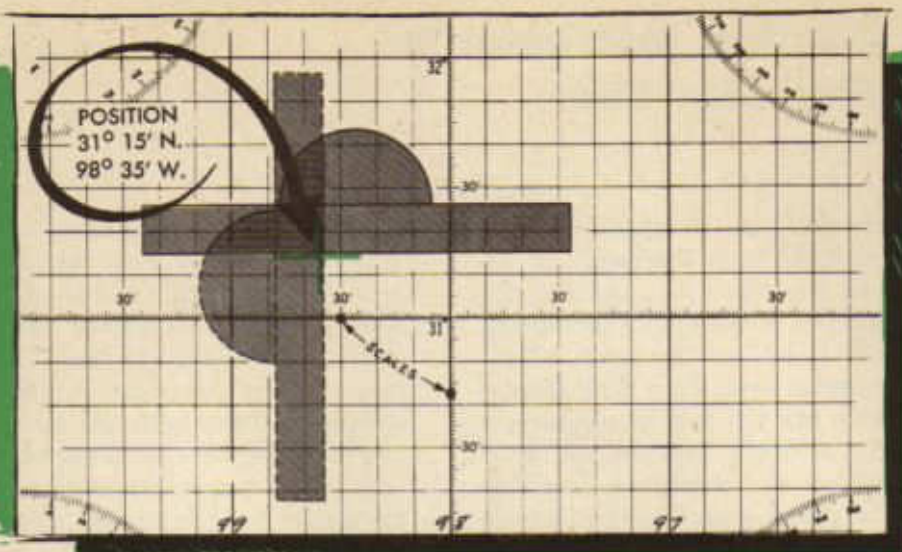

chart (turn it upside down). The longitude scale is constant and for this reason the meridians are unnumbered on the projection. Any particular Mercator can be used for any desired longitude, east or west. Mercators for any particular flight need only be selected for the latitudes to be covered. Recall that longitude is measured east and west from the Greenwich meridian. Therefore the navigator designates the meridians according to his position on the surface of the earth, increasing from left to right in east longitude and increasing from right to left in west longitude. One of the primary sources of plotting error is the incorrect numbering of meridians. Student navigators must be particularly careful in this respect.



Assume that a VP-3 Mercator plotting chart has been selected for use in some particular flight and the meridians have been designated to cover from 95°W to 100°W . It is now possible to plot a position whose coordinates are known. For example, to plot the position whose coordinates are $31^{\circ}15'\text{N}$ - $98^{\circ}35'\text{W}$, these steps are necessary. First, set the plotter at the proper latitude ($31^{\circ}15'\text{N}$) on the graduated latitude scale on two meridians, one on either side of the estimated position. Then draw a short line along the edge of the plotter at the approximate position of the desired longitude ($98^{\circ}35'\text{W}$). If the longitude of the position makes it impossible to extend the plotter between two



TO PLOT A POSITION FOLLOW
STEPS ONE AND TWO

graduated meridians, satisfactory results may be obtained by placing the plotter at the desired latitude on one graduated meridian and drawing a line parallel to one of the ten-minute interval lines of latitude, again checking to see that the line is at the approximate position of the desired longitude. Much the same procedure is used to plot the longitude. First, set the plotter at the desired longitude (98°35' W) on adjacent parallels of latitude that have graduated longitude scales. Draw a line along the edge of the plotter so that it intersects the line previously drawn. The intersection of the two lines represents the desired position. The plotting will result in two lines closely resembling the symbol for an auxiliary airfield. The position will never be plotted as a dot or a point.

The coordinates of a point may be determined easily and quickly in much the same manner. Place the plotter on the point and line up the plotter parallel to a parallel of latitude. Now read the latitude of the position on the adjacent graduated meridian. To obtain the longitude of a point, place the edge of the plotted at the point and align it parallel to a meridian. Now read the longitude of the position on the adjacent graduated parallel of latitude.

When the earth is visualized as a sphere it can readily be seen that the length of a

minute of latitude (a nautical mile) is constant. Therefore it affords a convenient measure of distance. On the other hand, the length of a minute of longitude varies from being equal to one minute of latitude at the equator to zero at the pole. Consequently, it is of no value as a measure of distance. At first glance it would seem that these conditions are reversed on a Mercator projection since the length of a minute of latitude increases steadily north or south of the equator, while the length of a minute of longitude is constant throughout. However, it is necessary to recall the nature of the construction of this projection of the earth's surface (a sphere) on a chart. The distortion results in the latitude's increasing steadily north and south of the equator. Hence, it is necessary to use a measurement for distance that varies in the same way. This is provided by the latitude scale. All measurements of distance, therefore, must be on the mid-latitude scale of the area under consideration.

Suppose A, B, and C, are parallels of latitude and it is desired to measure the distance XZ. Open the dividers to cover the distance XZ and then put them on the latitude scale so that there is approximately the same span either side of the mid-latitude point B. The number of minutes of latitude (nautical miles) between the extended points represents the distance from X to Z. If the line

is too long for the span of the dividers, select a convenient number of minutes spaced equally either side of B and lay off this interval along the line XZ as many times as this interval is fully contained in the distance XZ. Then measure any residual distance, again using the mid-latitude scale, equally, on either side of point B. The distance XZ is then equal to the sum of these partial measurements.

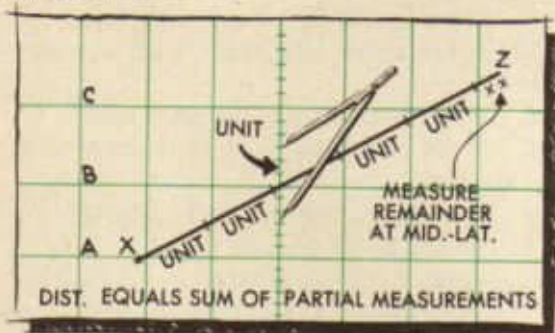

In measuring course angles any meridian can be used since all meridians are parallel straight lines. The first step in determining a course between two points is to place the plotter along the line joining the two points. Then slide the plotter along the course line until the hole in the center of the radiating angle lines is on a meridian. Read the true course on the protractor scale at this meridian. Care must be exercised to use the small direction arrows on this protractor scale.

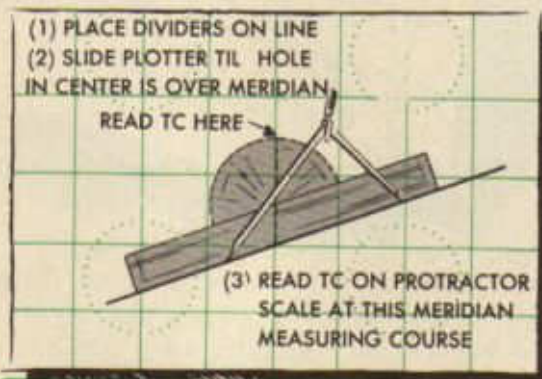

These arrows indicate which scale should be read, depending on the direction of the flight. It can be observed that one scale is the reciprocal of the other and results in 180° errors in measurement. By placing the points of the dividers on the course line, accuracy and speed in the use of the plotter can be improved.

When it is necessary to draw a certain course from a given point, much the same procedure is used. Place the point of a pencil on the given point and then slide the plotter along the pencil until the desired course on the protractor scale and the hole at the center of the plotter both are on the meridian. The desired course line can then be drawn along the bottom of the plotter.

When the course angles approach 180° or 360° it is often difficult to measure the angle on a meridian. In this case it is suggested that the course be measured along a parallel of latitude. This will result in an answer 90° off. The correct answer can then be obtained by adding or subtracting 90°.

At times the navigator will want to plot on his chart a course in which the distance between departure and destination is too great to permit the plotting of both points. If the course is known and is in an easterly or westerly direction, the entire distance may be plotted on one Mercator.

Suppose that it is necessary to plot a course between point A and point B. The

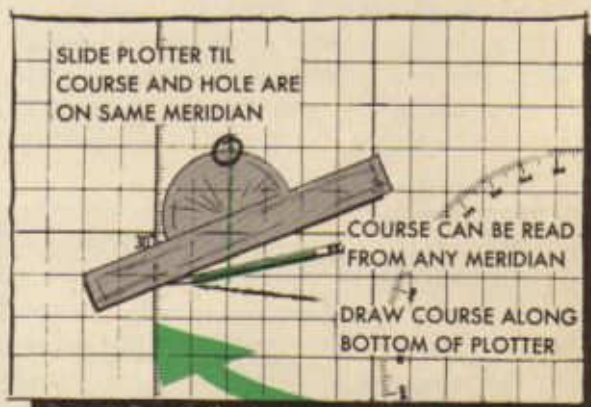

DRAWING A COURSE FROM A KNOWN POSITION

course is known to be 075, but the distance between the two points is too great to plot as a straight line on an ordinary Mercator plotting sheet. However, lay off the predetermined course from departure point until it runs off the Mercator chart, then determine the coordinates of that point (x). This position can then be replotted on the opposite side of the Mercator. To do this, it is necessary to re-number the meridians, starting with the longitude at which the course left

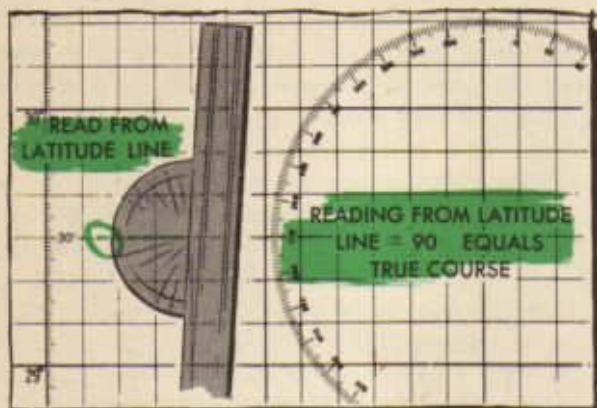

WHEN COURSE IS NEAR 180 OR 360

the Mercator. The latitude of the point will remain the same. From this re-plotted point, the course line can again be laid off. Within the limits imposed by the latitude bands, this procedure can be repeated until destination is reached.

If the course to be plotted runs in a northerly or southerly direction, the point at which the course leaves the Mercator must be determined and re-plotted on an adjoining Mercator. Due to a difference in longitude scale, it is impossible to join two VP Mercators and draw a course line direct from departure to destination.

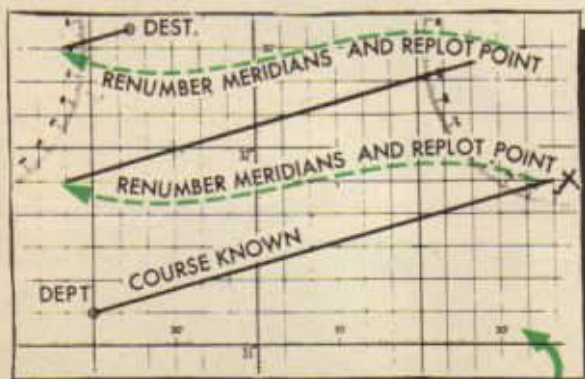

WHEN DISTANCE IS TOO GREAT FOR STRAIGHT LINE

It is a good habit for students to label each point and each line drawn on a Mercator. This will prevent many plotting errors. It is absolutely necessary to check all measurements of both courses and distances. This double check should be automatic for each student.

Finally, these rules should always be in mind when a student is working with a Mercator chart:

1. Never mark the chart with ink.
2. Never mark the chart with a colored pencil.
3. Always use a soft, artgum eraser.
4. Avoid punching holes in the chart with the dividers.
5. Use a hard, sharp pencil and draw lines light enough to be erased.
6. Always roll the chart; never fold it.

The Mercator chart is the navigator's record of his progress on a particular flight. The

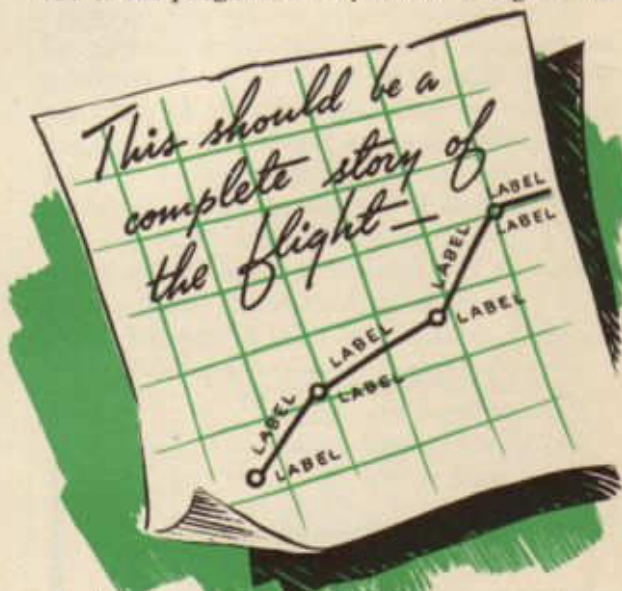

student navigator must develop speed, accuracy, and care in its use. Students should make a note of each and every plotting error and resolve that this same error will not be repeated.

In addition to the Mercator plotting chart, the navigator often will use conformal charts of one type or another for precision dead-reckoning chart work. At this time, the student will do well to review the section devoted to the conformal chart, giving especial attention to the instructions for plotting on that chart.

Other Dead-Reckoning Charts

There are available to the navigator, both during training and in service, the following types of navigation charts:

1. For planning of long flights, there is available with complete world coverage the series of *World Planning Charts* on the Lambert Conformal projection, scale 1:5,000,000.

2. For plotting long flights, the *Army Air Forces Long Range Air Navigation Charts* (scale 1:3,000,000) are available. There is complete world coverage with this type of chart, and the principal land features are indicated. From 60°N to 60°S these charts are on the Mercator projection and hence are very satisfactory for plotting purposes. The polar regions are covered in this series by charts on the stereographic projection. For the North Atlantic crossing, South Atlantic crossing, and the crossings from California to Australia and on to India, there is the somewhat similar series of *Army Air Forces Special Charts*, which are Mercators on the scale of 1:5,000,000.

3. Where there is need for a larger scale Mercator having land features indicated, there is the *V-30 Air Navigation Chart Series* (scale 1:2,188,800) published by the Hydrographic Office of the Navy Department. These charts, having about the same features indicated as the *Army Air Forces Long Range Air Navigation Charts*, provide complete world coverage from 75°N to 75°S, and are of recent issue, having been first published in May and June, 1943.

4. If a still larger scale plotting chart is desired, there is the *GSGS 4080 Plotting Series* (scale 1:1,000,000) containing principal land features, but without air information. This series, which was originally designed for another use, is also on the Mercator projection; and, although it does not provide complete world coverage, charts of the series are available for most combat areas.

5. For the United States there is a special *U. S. Plotting Series* of charts, which are Mercators on the scale of 1:1,000,000. These are excellent plotting charts, particularly for short flights.

6. The Hydrographic Office series of *VP Plotting Sheets* are, of course, blank with regard to longitude specification. Each sheet applies to no definite area and, consequently, there is no indication of land features. This is the most serious drawback of the VP series and is the principal reason why the plotting charts mentioned under paragraphs 2, 3, 4, and 5 are superior. In actual practice the navigator would normally use a VP chart only if no plotting chart of the previously mentioned types were available.

7. For map-reading purposes, there are *Army Air Forces Aeronautical Charts* and the *Western Hemisphere Pilotage Charts* on the same scale (1:1,000,000) as the *U. S. Regional Charts* (which are a part of the *Western Hemisphere Series*) available for practically all the land areas of the world. Large scale (1:500,000) map-reading charts similar to the *U. S. Sectionals* are available in the *Army Air Forces Aeronautical Chart* series for the Japan area and in the *GSGS 4072 series of European Pilotage Charts* for most of Europe and the Mediterranean area. Some of the charts in the European series, principally for certain portions of Germany, France, Belgium, Holland and all of Italy, are on the scale of 1:250,000. Map-reading charts for Africa are available on a scale of 1:2,000,000 in the *Africa Pilotage Chart Series*. Part of Canada is covered by the *Canadian Pilotage Chart Series* on the scale of 1:506,880.

8. The *Army Air Forces Aeronautical Approach Chart* series is planned to cover all the land areas of the world on a scale of 1:250,000. Those available at present include the Aleutians and part of Alaska, Southwest Canada, Iceland, a small part of SW United States, the Great Lakes Region, Southern Florida, Turkey, parts of India and Persia, the Philippines, Dutch East Indies, parts of Australia, Hawaiian Islands, Solomon Islands, New Caledonia, and the Fiji Islands. This series, when completed, will constitute the finest map-reading charts available.

The navigator can secure full information on all these charts in the *Catalog of Aeronautical Charts and Related Publications* issued by the Aeronautical Chart Service, Headquarters, Army Air Forces, Washington, D. C.

GENERAL DEAD-RECKONING TECHNIQUES

Vectors

A thorough understanding of the solution of problems involving speed (or force) and direction is of fundamental importance to every navigator. The combination of speed and direction with which the navigator is so vitally concerned is called *velocity*. A velocity may be defined as a rate of change of position in a given direction. Or, more simply, a velocity is a speed (or force exerted) in a given direction. Note that a velocity consists of *both speed and direction*. To say that an aircraft has a velocity of 200K is incorrect. The direction of the motion must be given. If the aircraft is moving in the direction of 090 at a speed of 200K, the aircraft has a *velocity* of 090/200K.

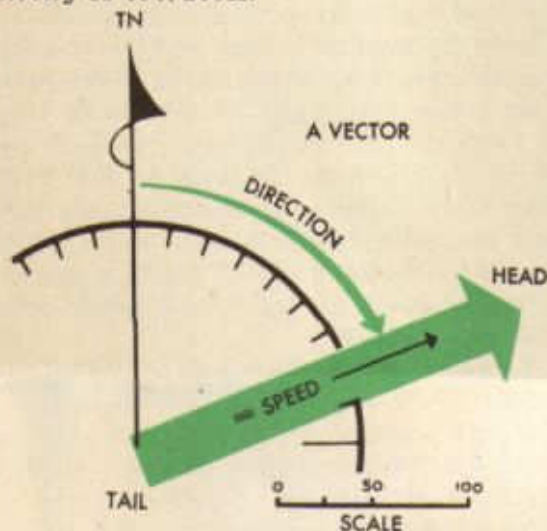

A velocity may be represented by a *vector*. A vector is a graphical representation of a velocity. Or, more simply, a velocity may be represented by a straight line. The length of the vector will be equal to the speed or force of the velocity, drawn to some convenient scale, and the direction of the vector will be the true direction of the velocity, considering the top of the paper on which the vector is drawn to be true north. Since the scale representing speed or force varies from problem to problem, the scale used must be appar-

ent or indicated on all vectors. A vector always must be drawn *from* some point or origin (called the *tail* of the vector) in the proper direction and to the proper length, and end in an arrow-head (called the *head* of the vector). While the length of a vector usually represents speed in units of one hour (either miles per hour or knots), vectors may be drawn to represent either more or less than one hour. The only thing to be careful about is to be sure to draw the vector the proper length. A vector representing a wind velocity of 080/20K for thirty minutes would

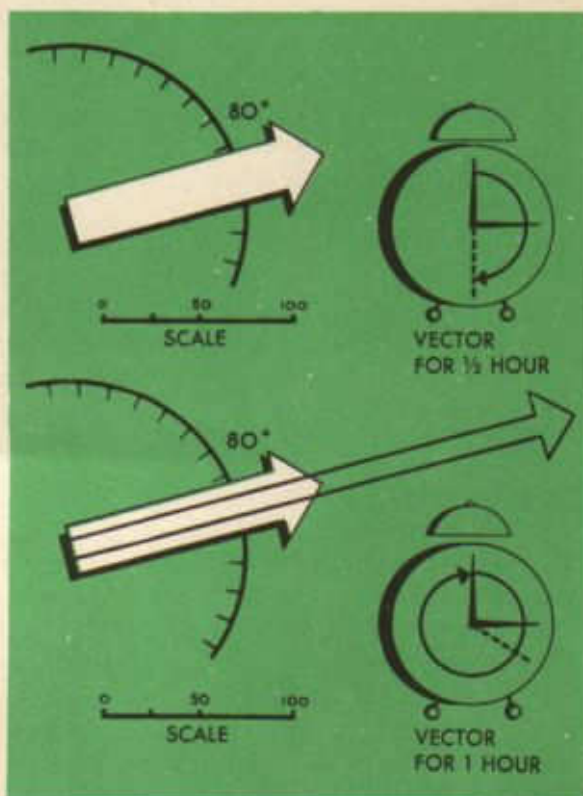

be just half as long as a vector representing the same velocity for one hour. In a like manner, a vector representing a velocity for an hour and a half would be one and a half times as long as a vector representing the same velocity for one hour.

An aircraft, a boat, or any body may be subject to or acted on by two or more velocities at the same time. When this is true, the velocities acting on the body are called *component* velocities and the resulting velocity of the body, caused by these component velocities is called the *resultant* velocity. It likewise is true that any body may be acted on by two or more velocities in turn, that is, by one velocity for a certain length of time and then by another for another length of time, and so on. But the velocities acting upon the body are still called component velocities and the resulting velocity is still called the resultant velocity. And, furthermore, the *resultant velocity is the same* regardless of whether the component velocities acted upon the body at the same time or in turn. That being true, velocities always are considered to act upon a body in turn.

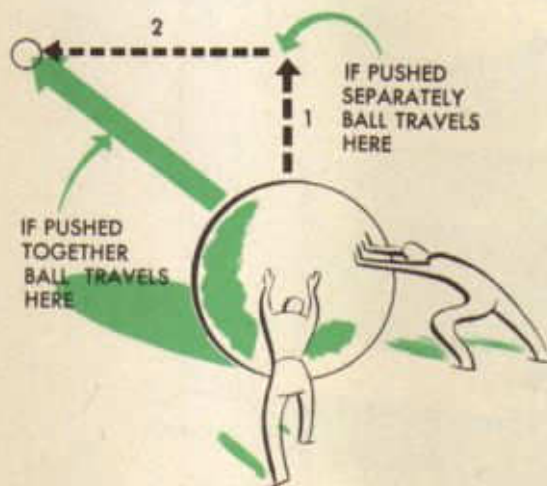

In order to solve problems involving velocities, *vector diagrams* are used. In vector diagrams, vectors representing component velocities are called *component vectors*, and vectors representing resultant velocities are called *resultant vectors*. Component vectors always are drawn tail-to-head, that is, the tail of the second component vector is at the head of the first, and so on. The resultant vector *always* is drawn from the tail of the first component vector to the head of the last component vector. Thus, any missing vector, either component or resultant, may be found and easily identified.

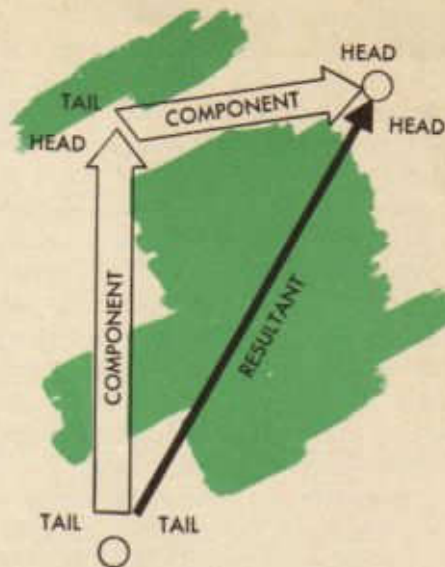

Component velocities may act upon a body in the same straight line, either opposing or assisting each other. When this is true, the resultant velocity is on the same line. If the component velocities oppose each other, the resultant velocity will be in the direction of the component having the greater speed (or force) and will have a speed (or force) equal to the difference of the speeds (or forces) of the components. If the component velocities assist each other, the resultant velocity will be in the direction of the components and will have a speed (or force) equal to the sum of the speeds (or forces) of the components.

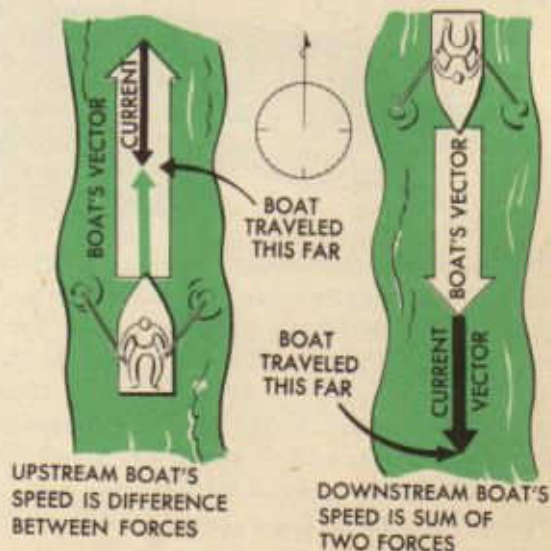

To illustrate this type of vector problem, consider a boy who can row a boat at 4 mph in a south-flowing river whose current is 1 mph. If he rows up the river, the component velocities (the boy's rowing velocity of 360/4 mph and the current's velocity of 180/1 mph) will oppose each other and the resultant velocity (the direction and speed which a person on the bank would have to move to keep abreast of the boat) would be 360/3 mph or the direction of the stronger component, (the rowing component direction of 360), and a speed equal to the difference in the speeds of the components (rowing speed 4 mph minus current speed 1 mph). If the boy rows down stream, the components will assist each other and the resulting motion of the boat (resultant velocity) will be 180/5 mph, the mutual direction and the sum of the speeds of the components.

THIS BOY WALKS 3 MPH
TO KEEP UP WITH BOAT



But component velocities rarely act upon a body in a straight line. When they do not, the resultant velocity is found easily by vectors. Consider the case of a power boat heading 090/8K, trying to cross a bay 8 NM wide whose current is 180/4K. Where would the boat be at the end of one hour? It would be, obviously, at a point 8 NM east and 4 NM south of the starting point. To solve this problem with vectors, lay down the first com-

ponent (boat) vector (090/8K) with its tail at the starting point; lay down the second component (current) vector (180/4K) with its tail at the head of the first vector. To find the resultant velocity (the boat's actual direction and speed made good) lay down the resultant vector with its tail at the tail of the first component vector and its head at the head of the last component vector.

Remember that a body may be acted upon

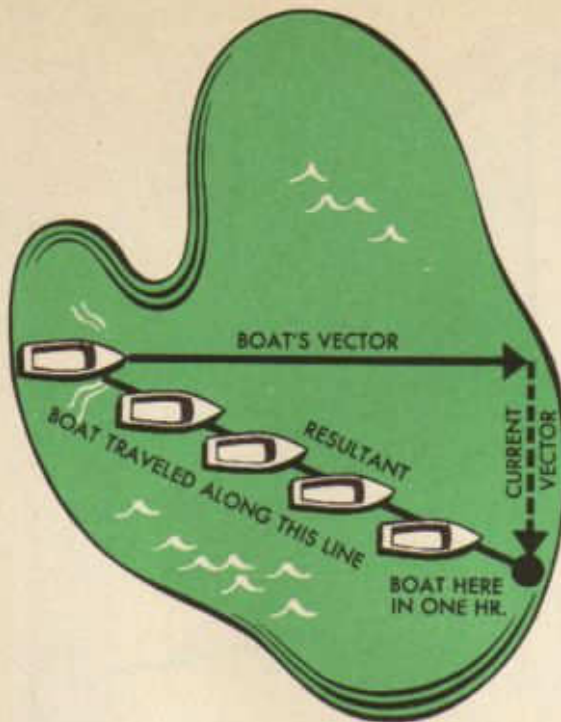

by any number of velocities, either simultaneously or in turn. In every case, though, the general rule holds. Plot the component vectors tail to head, in turn, and plot the resultant vector from the tail of the first component vector to the head of the last. To illustrate, consider a problem: A ship, on a course of 030 T has a speed of 10K, a tide of 300/3K, and a leeway of 145/2K caused by a gale. What track and speed is it making good? Apply the component vectors AB, BC, and CD in turn to find the resultant vector AD, the required track and speed.

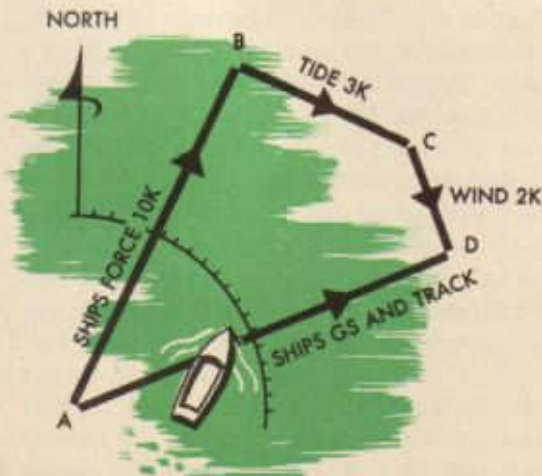

These examples illustrate the general rule: When a body is subject to two or more component velocities, its resultant velocity is found by applying the component velocities in turn. The resultant velocity is, then, the *vector sum* of the component velocities. This process is called *adding velocities* or *vector addition*, and the resultant is called the *vector sum*. When adding vectors, remember that (1) each component vector must represent the same length of time as the other or others, and (2) the resultant vector will be for the same length of time as each component.

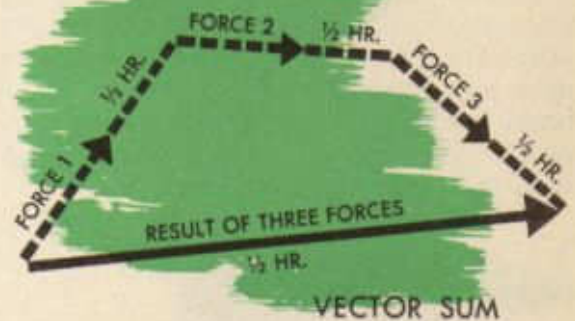

Often it is desirable to obtain a *mean* or *average* of several vectors representing the same type of velocity. This is often true in handling a number of wind velocities. For example, the following five winds have affected an aircraft, each for one hour; what is the mean or average effect?

- Wind velocities:
1. 030/20K
 2. 050/25K
 3. 075/30K
 4. 095/30K
 5. 115/40K

Represent each wind by a component vector, AB, BC, CD, DE, and EF, apply them in turn, tail to head, and draw the resultant vector, AF. This resultant, AF, represents five hours of wind, since each component repre-

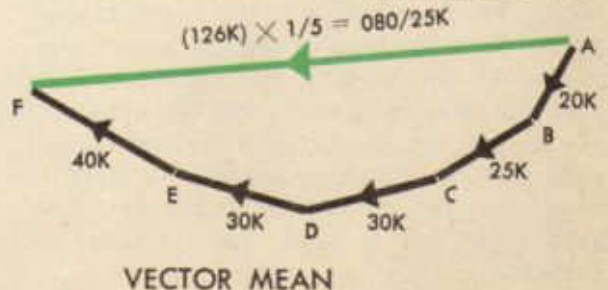

sents one hour. To find the vector mean in terms of one hour, therefore, divide the length of AF by five. This process is called *vectoral averaging* and the resultant represents a mean or average velocity and is called a *vector average* or *vector mean*. When averaging vectors, remember (1) the components may be for different lengths of time and (2) the resultant represents the *sum* of the times of the components.

An arithmetic average (mean) of such velocities may or may not differ appreciably from the vector average (mean). Such difference is caused by difference in the directions of the various vectors. When there is any considerable difference between the directions of any two vectors, *do not use* the arithmetic mean. The vector mean is always more accurate and ought to be used at all times, and if the directions of all the component vectors do not lie in the same quadrant, the vector mean *must* be used.

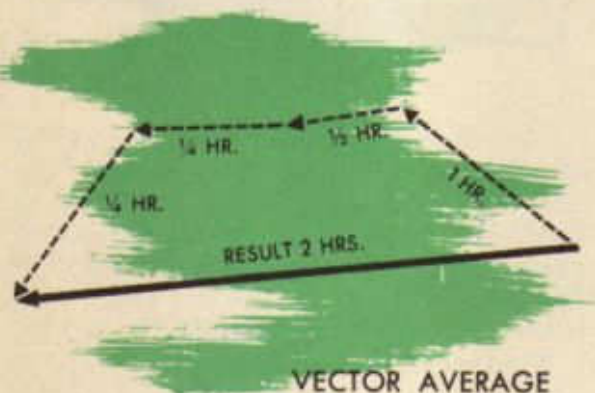

Sometimes, instead of knowing all the components and desiring to know the resultant, the navigator may know the resultant and all but one of the components and be required to find that one unknown component. In such cases, he lays down the resultant vector first. Then from the tail of the resultant vector, he lays down the known components, tail to head. Then he can draw in the unknown component from the head of the last known component to the head of the resultant. Note that the *first* component and the resultant are always *tail to tail*, that the *last* component and the resultant are always *head to head*; and the components always follow each other *tail to head*. This is very important.

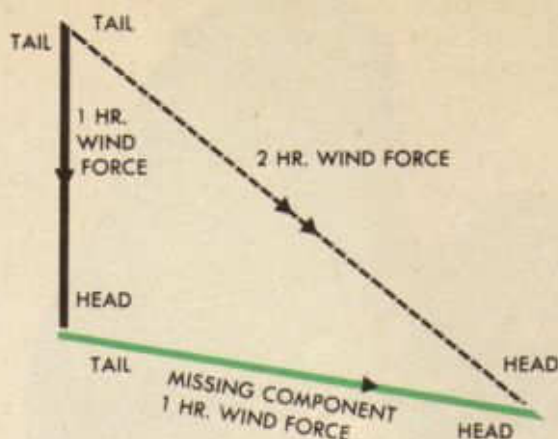

DETERMINING ONE COMPONENT

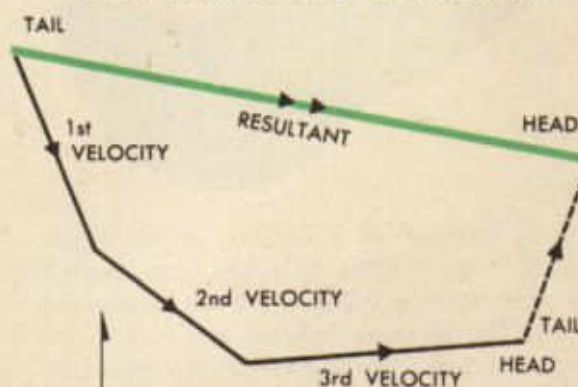

DETERMINING COMPONENT

At times it may be necessary to *add* two or more *series* of velocities, each of which have acted upon a body simultaneously or in turn. For example, it may be necessary to plot a series of TAS-TH vectors which have acted upon an aircraft for a given time and a series of wind velocity vectors which have acted during the same time. This problem is handled exactly as any other vector addition problem, treating each series as if it were a single velocity. This means that each series must represent the same *total* length of time as each other series represents. The *individual* vectors within the various series do not necessarily have to represent equal lengths of time, but greater accuracy results if they do. All the vectors of the TAS-TH series

are plotted in turn, then all the vectors of the wind velocity series are plotted in turn. The resultant, then, may be plotted as usual, from the tail of the first to the head of the last vector. The time represented by the resultant will be the total time of *one* series, *not* the sum of the times of all the series.

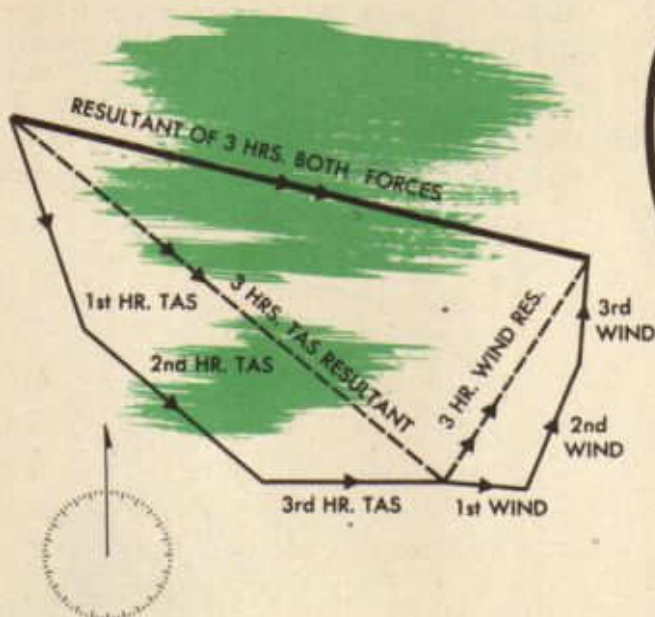

Or, at times, it may be desirable to *average* series of vectors. For example, it might be necessary to average several series of winds that have affected an aircraft over a long period of time. In this case, the winds of the first series are plotted in turn, followed by the winds of the succeeding series plotted in the same manner. The resultant is plotted as usual. The thing necessary to remember is that the resultant represents the *sum* of all the times of all the series.

In summary, these are the important facts to remember about vectors:

1. A *velocity* consists of both speed and direction.

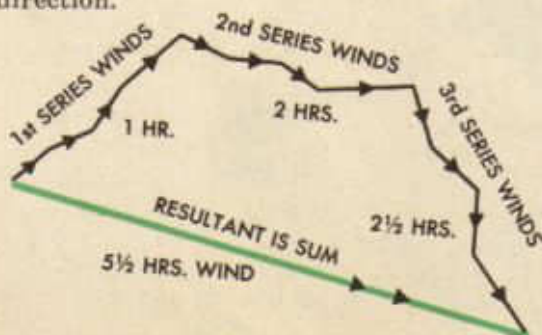

2. A velocity may be represented by a *vector*.

3. Vectors may represent more or less than one hour.

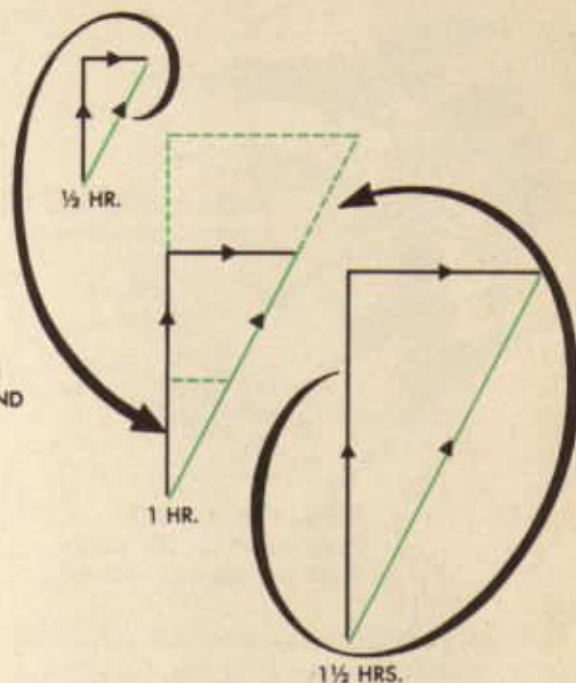

4. Velocities acting simultaneously or in turn are called *component* velocities, and produce a *resultant* velocity. These velocities may be represented in a *vector diagram*, in which component velocities are represented by *component vectors* and resultant velocities, by *resultant vectors*.

5. Component vectors always are laid *tail to head*; the resultant vector is always laid from the *tail* of the first component to the *head* of the last. Thus, any missing vector, either component or resultant, may be found.

6. When vectors are *added*, (1) each component must represent the same length of time as each other component, and (2) the resultant represents the same length of time as a single component.

7. When vectors are *averaged*, (1) component vectors do not necessarily represent the same length of time, and (2) the resultant vector represents the *sum* of the times of all the component vectors.

8. When *series* of component vectors are either added or averaged, a *complete series* is treated as a *single vector*.

Wind Triangles

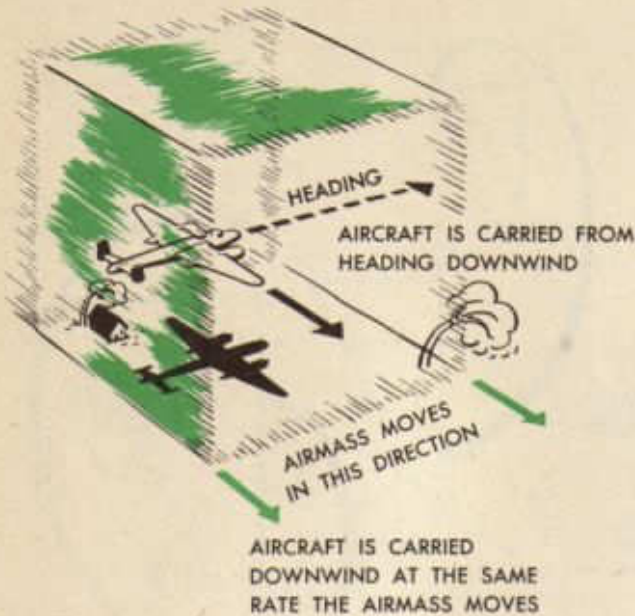

With an understanding now that velocities may be solved graphically, the student is ready to solve the velocity problems which affect his aircraft. These problems, while relatively simple, are in fact the very basis of precision dead-reckoning. Two component velocities always act upon an aircraft and determine its resultant motion. The first component velocity is the TH-TAS (True Heading-True Airspeed) velocity given the aircraft by the pull of the engines through the propellers. The second component velocity is the velocity given the aircraft by the movement of the mass of air in which it is flying. This movement of the mass of air is, of

course, the wind. Since the aircraft is suspended in a moving mass of air, it moves with the air, just as a balloon moves with the air. A balloonist, since he is suspended in and moving with the air mass, never feels any wind, since no air moves past him. He is moving with it. So is an aircraft. If the student will keep this fact in mind, it will keep him from making many foolish errors. This second component velocity includes both W/D (Wind Direction) and W/F (Wind Force); it usually is referred to as W/v (Wind Velocity). The resultant of the

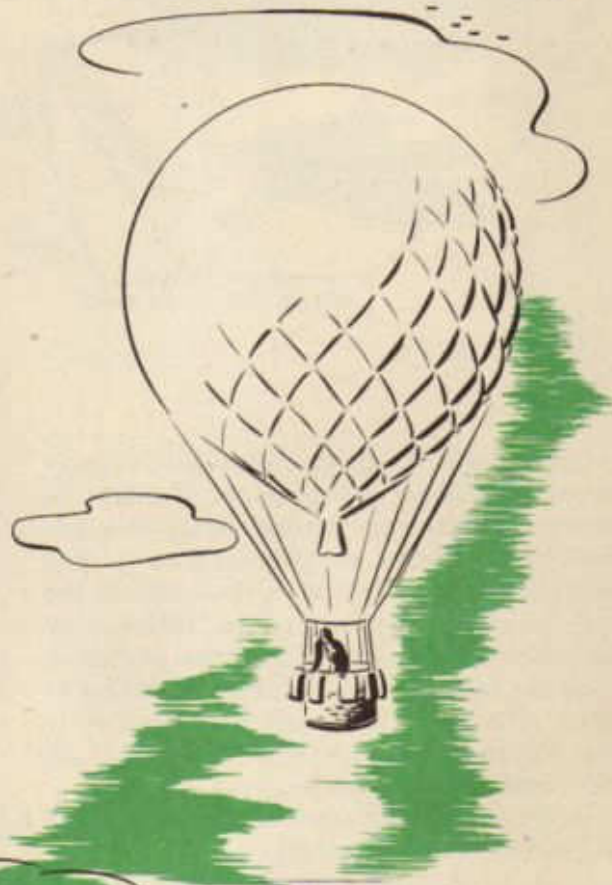

OBJECTS FREE TO MOVE
IN AIR DO NOT FEEL THE
WIND

two component velocities (TH-TAS and W/v) is the Tr-GS (Track-Groundspeed) velocity. Thus, the student works with three velocities, each composed of two factors. The student knows (1) that he can represent by vectors any of these velocities he may know, and (2) that when he knows any two of the three, he can find the third by means of a vector diagram. The vector diagram which the student uses to solve for these velocities is called a *wind triangle*. Too much emphasis cannot be placed upon the four following simple facts about wind triangles:

1. True heading (TH) and true airspeed (TAS) go together and make up the first component vector.
2. Wind direction (W/D) and wind force (W/F) go together, are called wind velocity (W/v), and make up the second component vector.

3. Track (Tr) and ground speed (GS) go together and make up the resultant vector.

4. Wind always blows from heading to track.

There are several types of wind triangle problems, depending upon what values are known. The first and simplest type is that in which the two component velocities (TH-TAS and W/v) are known, and it is required to find the resultant velocity (Tr and GS).

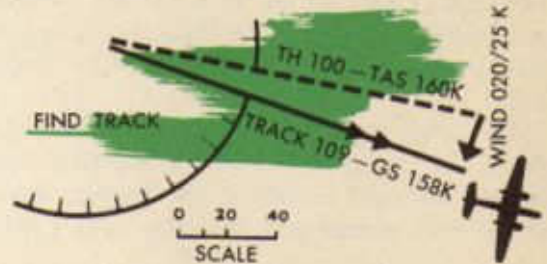

An example will illustrate this type:

- Given: 1. TH = 100 TAS = 160K
2. W/v = 020/25K

Find: Tr and GS

From an origin point, the first component vector (TH-TAS) is drawn toward 100° (TH) and to a length of 160 (TAS) units on a convenient scale. (If wind triangle work is done on a Mercator chart, the mid-latitude scale must be used.) At the head of the first component vector (TH-TAS), the second component vector (W/v) is drawn from 020° (W/D) and 25 (W/F) units long. The resultant vector (Tr-GS) is drawn from the tail of the first component (TH-TAS) vector to the head of the second component (W/v) vector. When this resultant vector is measured, track is found to be 109° and groundspeed, 158 K.

The second type problem generally considered is one in which the first component velocity (TH-TAS) and the resultant velocity (Tr-GS) are known; and it is required to find the second component velocity (W/v).

- Given: 1. TH - 270° TAS - 180K
2. Tr - 280° GS - 165K

Find: Wind velocity

From the origin point, the first component vector (TH-TAS) is drawn toward 270° (TH) and to a length of 180 (TAS) units.

From the tail of the first component vec-

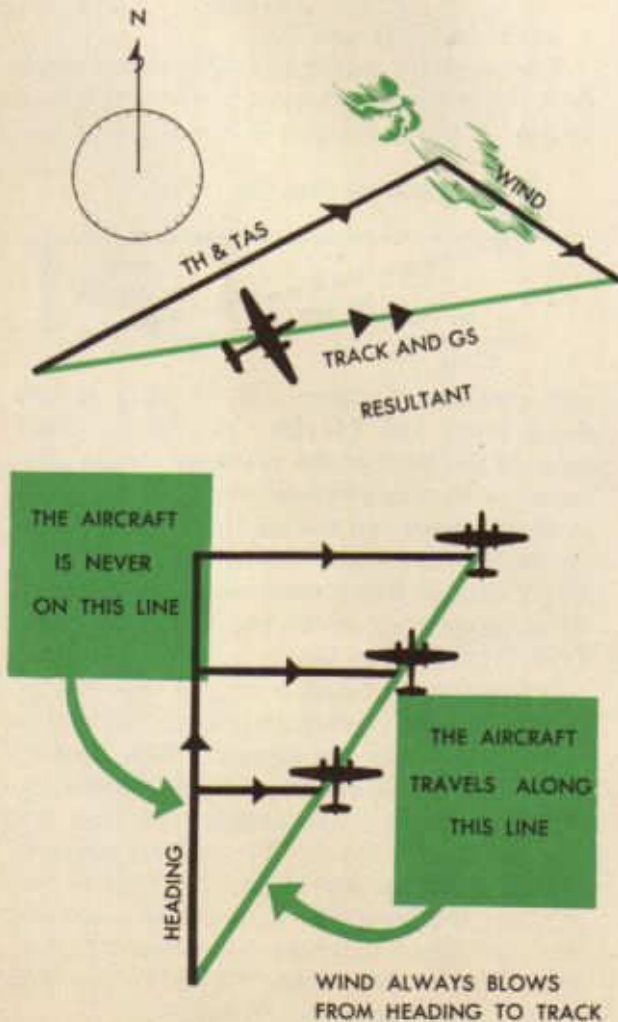

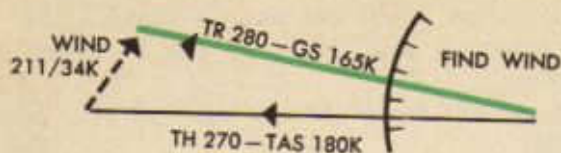

tor (TH-TAS) just drawn, the resultant vector (Tr-GS) is drawn in the direction of 280° (Tr) and to a length of 165 (GS) units. The required second component vector (W/v) is drawn from the head of the first component vector (TH-TAS) to the head of the resultant vector (Tr-GS). When measured, the direction of this second component vector (W/v) will be the wind direction (211°) and its length will be wind force (34K).

The third type problem is the type with which the navigator is most frequently confronted. In this problem, one factor, TAS, of the first component velocity (TH-TAS),

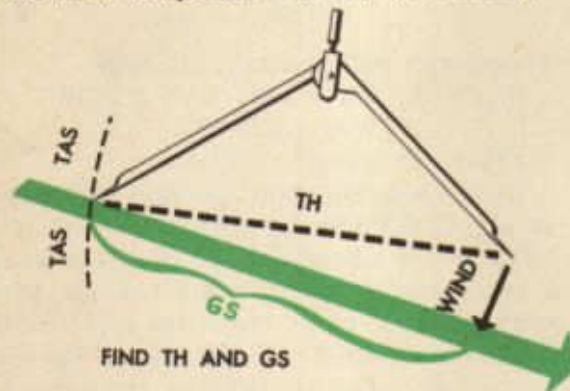

the entire second component velocity (W/v), and one factor, TC (True Course or desired Tr), of the resultant velocity (Tr-GS) are known. It is required to find the missing factors — TH in the first component velocity and GS in the resultant velocity.

- Given: 1. TAS - 160K
2. W/v - 020/25K
3. TC - 109

Required: TH and GS.

The resultant vector (TC-GS) is drawn first, toward 109°. Since groundspeed is not known, it cannot be of a definite length at this time. From 020° (W/D) the second component vector (W/v) is drawn, 25 (W/F) units long, to the head of the resultant vector. From the tail of the second component vector (W/v) swing an arc of 160 (TAS) units to intersect the resultant vector (TC-

GS), thus establishing the tails of both the first component vector (TH-TAS) and resultant vector (TC-GS). From the tail of the resultant vector (TC-GS), then, the first component vector (TH-TAS) is drawn to the tail of the second component vector (W/v), completing the triangle. The direction of the first component vector (TH-TAS) then is measured to find TH (100), and the length of the resultant vector (TC-GS) is measured to find GS (158K).

The fourth type wind triangle problem is one in which the second component vector (W/v) and the resultant vector (TC-GS) are given, required to find the first component vector (TH-TAS). This is the type problem that must be solved when it is imperative for an aircraft to arrive at a certain point at a given time.

- Given: 1. TC = 090 GS = 150K
2. W/v = 180/30K

Required: TH and TAS

The resultant vector (TC-GS) is laid down first, from the origin toward 090 (TC) to a length of 150 (required GS) units. The sec-

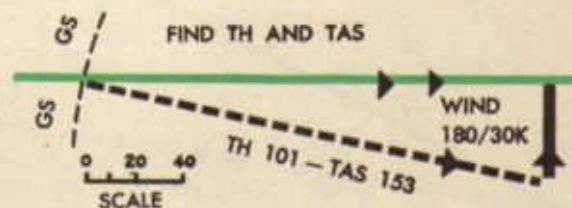

ond component vector (W/v) then is laid down from 180 (W/D), 30 (W/F) units long, to the head of the resultant vector. The required first component vector (TH-TAS) is drawn from the tail of the resultant vector to the tail of the second component vector. This first component vector (TH-TAS), when measured, gives the TH (101) and TAS (153K).

Other uses of wind triangles, as well as the use of other vector diagrams, will be discussed later. For the present, these uses of the wind triangle are of primary importance. It is important to remember (1) that the head of a TH, TC, or Tr vector always is toward the direction of the TH, TC, or Tr, (2) that the head of a W/v vector always is from the direction of the wind, and (3) that wind always blows from TH to Tr (or TC, if the aircraft is not yet in flight).

Computer Solution of Wind Triangles

The vector face of the E-6B computer may be used to solve almost any vector problem, especially wind triangle problems. This face of the computer has three parts, (1) a circular, transparent *plate* to draw the vectors on, instead of a piece of paper, (2) a movable *frame* which may be revolved around the plate, and (3) a *slide* or card that is placed in the frame under the plate.

The plate has, in its very center, a small circle called the *grommet* and around its outer edge (circumference), a *compass rose* graduated in degrees. The movable frame

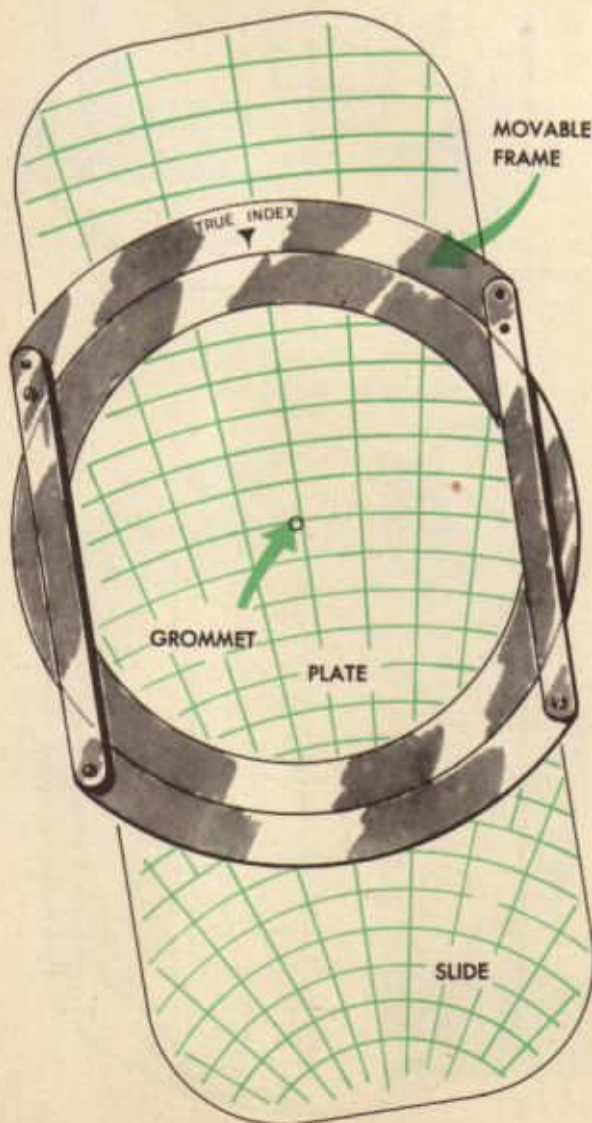

has on it a reference mark called the *True Index*, and, on either side of the True Index, a *drift scale*, graduated 45 degrees to the left and 45 degrees to the right of the True Index. The degrees on the drift scale are equal to the degrees on the compass rose of the plate.

The slide has printed on it a portion of a *circular graph* and a *square grid*. The circular graph has a *center line*, which lines up under the True Index and the grommet when the slide is placed in the frame. The center line has units of linear measurement indicated on it. The 30 on the bottom of the cen-

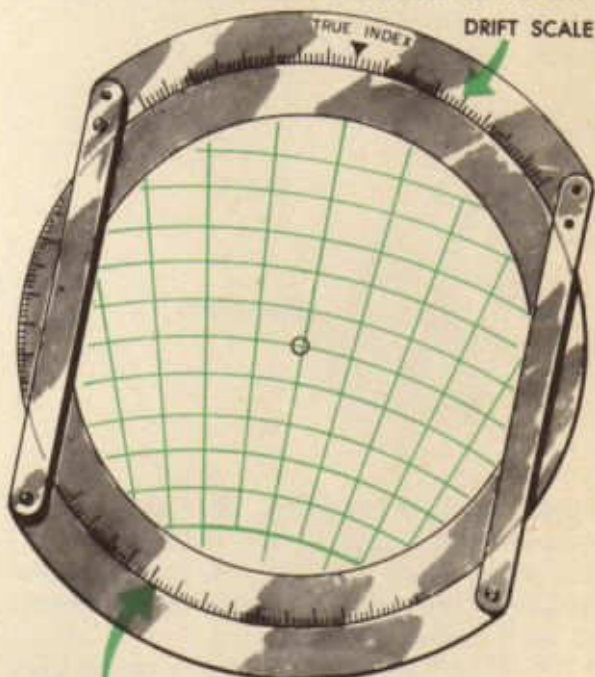

COMPASS ROSE
center line indicates that the origin of the center line is 30 units off the bottom of the slide. On either side of the center lines are *radiating lines* used to measure angular distance (in degrees) from the center line. The radiating line marked 10, for example, makes an angle of 010 with the center line. These radiating lines are drawn from the origin of the center line, 30 units off the bottom of the slide. They are called *TC lines*, *Tr lines*, or *drift lines*, according to the use made of them in a particular problem.

Speed circles, circles whose centers are at the origin of the center line (30 units off the bottom of the slide) and whose radii are the various lengths of linear measurement shown on the center line, are drawn two units of

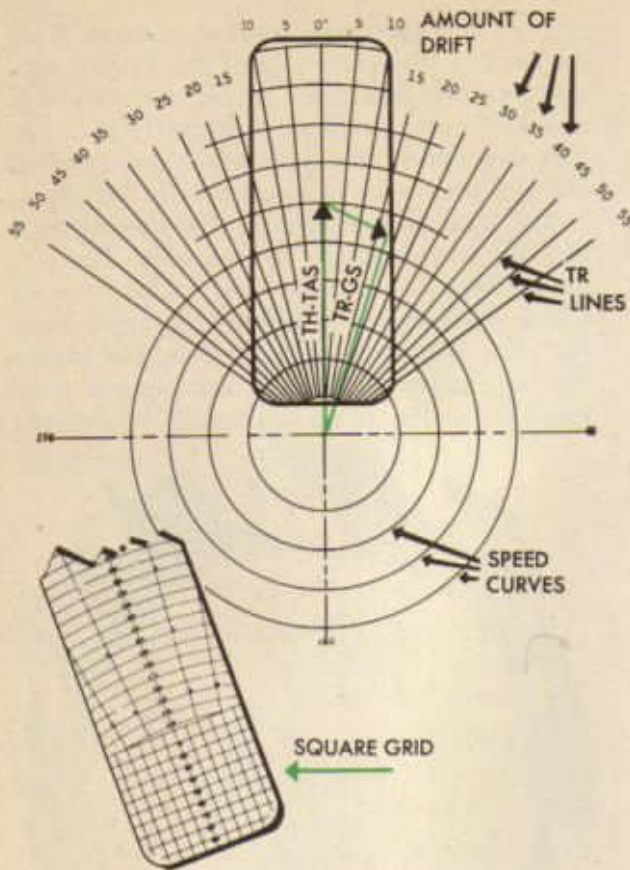

first component vector of a wind triangle (TH-TAS) is drawn *always* on the center line up to the grommet, with TH set at the True Index. Its tail, then, is off the origin of the center line and its head is

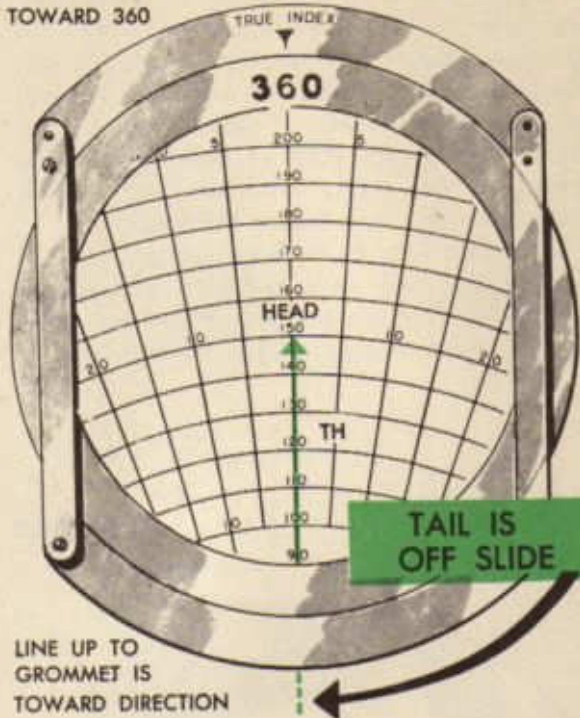

at the grommet. Its length (TAS) is indicated by whatever speed circle is set *under* the grommet.

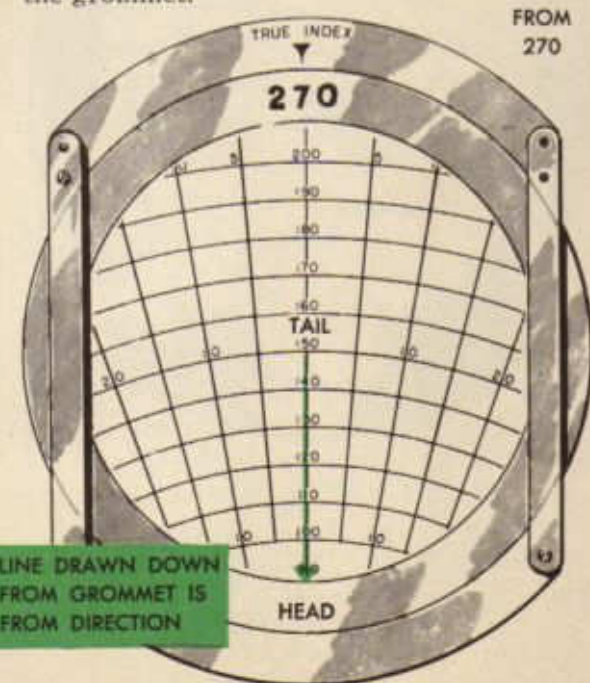

linear measurement apart. They are used to measure the length of the radiating lines. The speed circle marked 160, for example, measures 160 units of linear measurement on each radiating line.

The square grid likewise has a center line with units of linear measurement indicated on it. These units are the same length as those used on the circular graph. There are vertical lines, parallel to the center line, marking every two units of linear measurement, and horizontal lines at right angles (perpendicular) to the center line, likewise marking every two units.

When the vector face of the computer is used for solving vector diagrams, the slide is placed in the frame and the vectors, or portions of them, are drawn on the transparent plate by tracing over the lines of the slide. Particular attention is called to the important facts following.

1. Any line drawn on the center line up to the grommet is drawn toward the direction indicated under the True Index. The

2. Any line drawn on the center line *down* from the grommet is drawn *from* the direction indicated under the True Index. The second component vector of a wind triangle (W/v) is always drawn on the center line *down* from the grommet, with W/D set at the True Index. Its tail, then, is at the head of the first component vector at the grommet; its length is determined by W/F , using the units of linear measurement on the center line.

3. The resultant vector of a wind triangle (Tr-GS) is drawn along a radiating line (called, in this instance, a *Tr line*) *up* to the head of the second component vector (W/v) *after and only after* TH is set under the True Index and TAS is set under the grommet. Its tail, then, is with the tail of the first component vector (both off the card at the origin of the center line) and its head is at the head of the last (second) component vector. Its

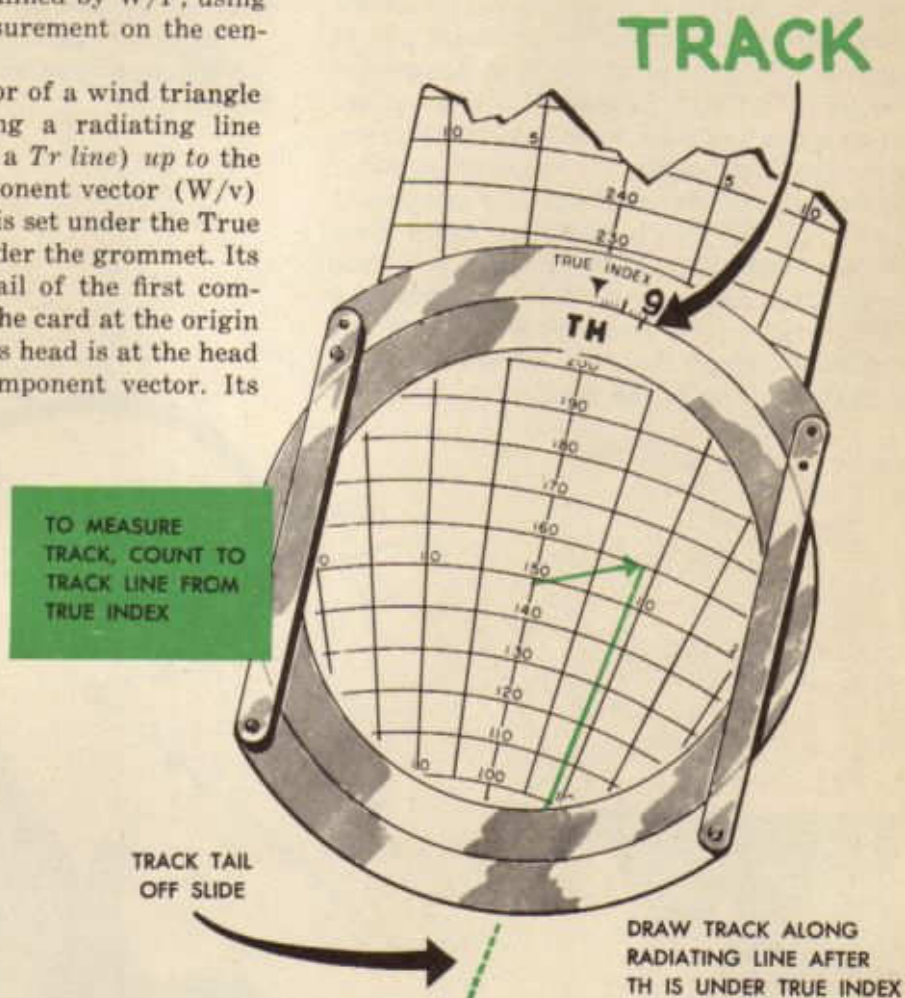

length is measured by means of the speed circles. Its direction is determined either by inspection or by measurement on the square grid. To measure the direction of the resultant vector by inspection, count the number of degrees of drift represented by the radiating lines between the center line and the resultant; count off that number of degrees on the drift scale *from* the True Index *toward* the resultant, and opposite that point read the direction of the resultant on the

compass rose scale. To measure the direction of the resultant on the square grid, place the square grid under the transparent plate, align the resultant (with its head *up*) with the vertical lines, and read the direction of the resultant at the True Index.

When wind triangle problems are drawn on the vector face of the computer, the parts of the triangle bear the same relation to one another as they bear when the triangle is drawn on paper. That relation in either case

is: component vectors tail-to-head; resultant vector tail to tail of first component vector, head to head of last component vector. It makes no difference which vector is put down first, which second, etc., as long as the relation is maintained.

The entire triangle, of course, cannot be drawn on the plate of the vector face of the computer. Actually, it is necessary to draw very little, if any, of it. The grommet always represents the head of the first component vector (TH-TAS), provided TH is set at the True Index and TAS is set under the grommet; the first component vector need never be drawn, therefore. The second component vector (W/v) always is drawn down from the grommet when W/D is set at the True Index. It is necessary to draw only the head of the vector (▼) at the proper point. The resultant vector (Tr-GS) is always drawn up a radiating line to the head of the wind. If

the wind is known, therefore, it is not necessary to draw the resultant vector, since the head of the wind vector indicates also the head of the resultant vector. It is well for a beginner, however, to draw as much of the triangle as possible, so as to avoid confusion. He later will be able to dispense with many of the lines, as he acquires proficiency (gets hot) on the computer.

The exact procedure for attacking and solving each type of wind triangle problem follows:

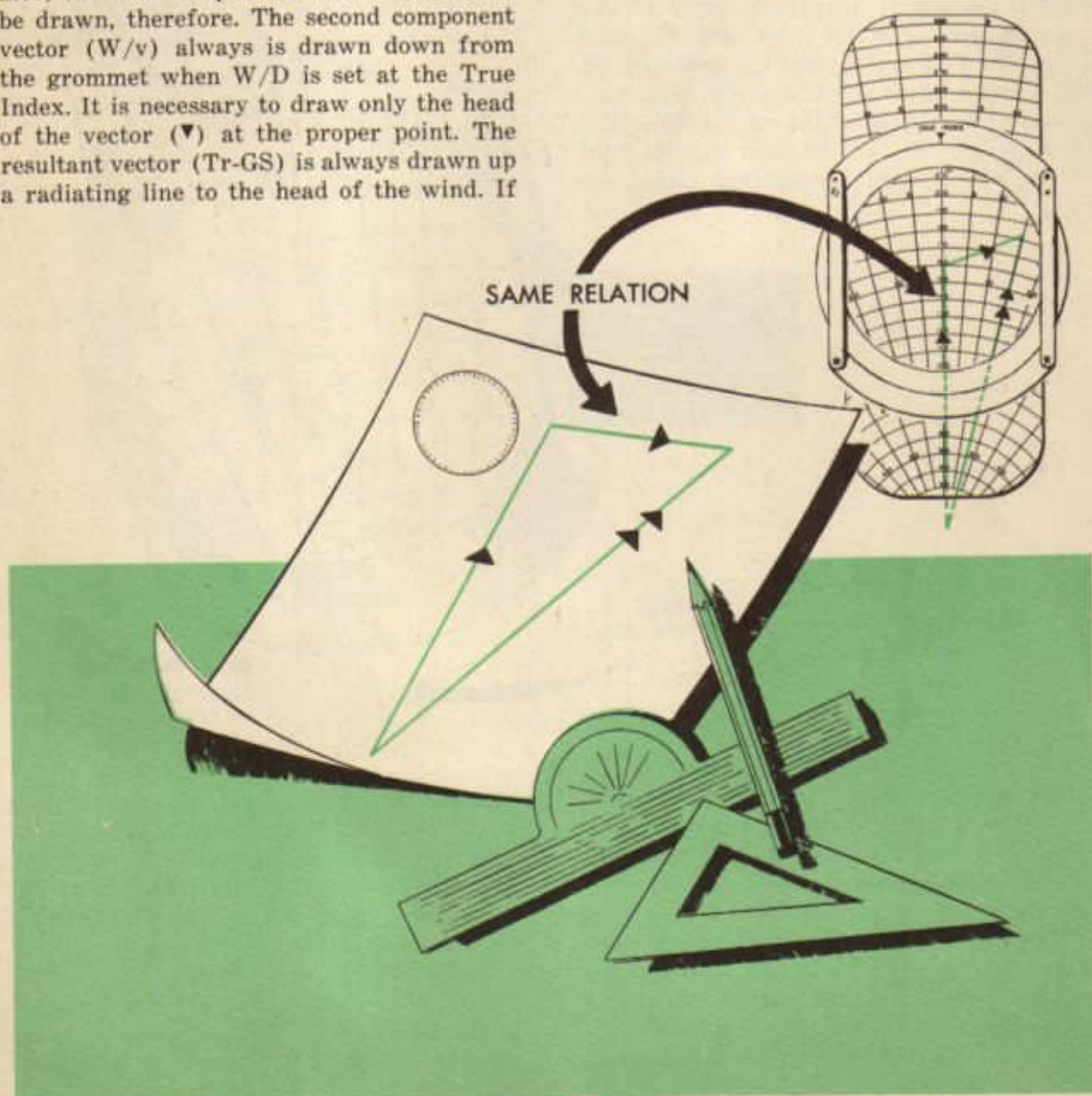

TYPE I

- Given: 1. First component velocity (TH-TAS)
2. Second component velocity (W/v)

Required: Resultant velocity (Tr-GS)

Problem

- Given: 1. TH = 100 TAS = 160K
2. W/v = 020/25K

Required: Tr and GS

Procedure:

1. Set W/D (020) under True Index.
2. Draw head of wind vector on center line down from grommet 25 units (12½ spaces).

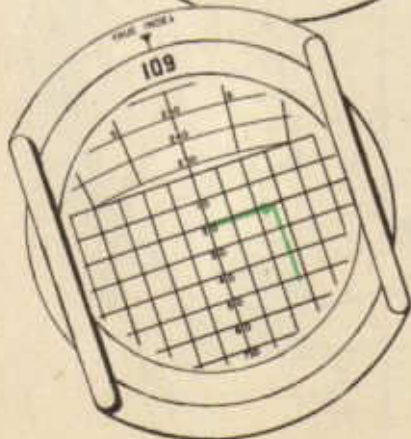
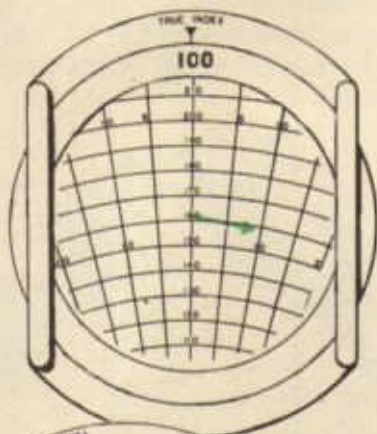
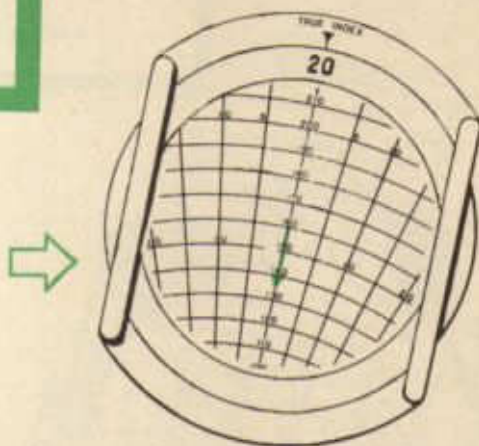

3. Set TH (100) under True Index.
4. Place TAS (160) under grommet.
5. Read GS (158K) on speed circle at head of wind.
6. Measure Tr by inspection:
 - a. Count degrees of drift between center line and head of wind (9).
 - b. Count 9 degrees on drift scale from True Index toward Tr or, in this problem, clockwise, and opposite 9 read direction of Tr (109) on compass rose.

- Or measure Tr by square grid:
- a. Draw Tr up radiating line to head of wind.
 - b. Place square grid under plate.
 - c. Align Tr with vertical lines, keeping head up.
 - d. Read direction of Tr (109) under True Index.

TYPE II

- Given: 1. First component velocity (TH-TAS)
2. Resultant velocity (Tr-GS)
Required: Second component velocity (W/v)

Problem

- Given: 1. TH = 270; TAS = 180K
2. Tr = 280; GS = 165K
Required: W/v

Procedure:

1. Place TH (270) under True Index.
2. Place TAS (180) under grommet.
3. Locate Tr (280) on compass rose and read drift (10) opposite it on drift scale.
4. Count off 10° of radiating lines from the center line in the same direction Tr is from TH on the compass rose (in this case, right) to locate Tr line.
5. Locate intersection of Tr line and speed circle indicating GS (165); draw head of resultant vector.

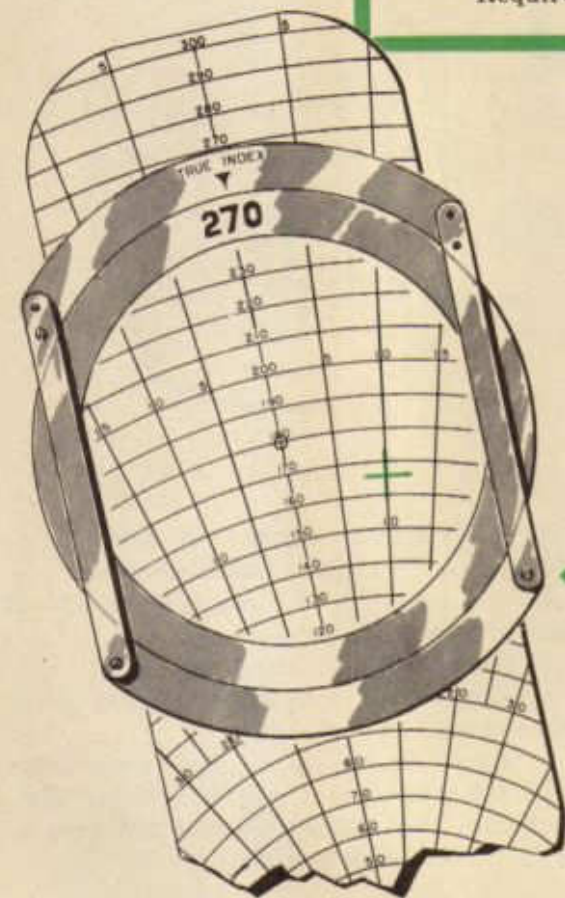

6. Place head of resultant vector on center line down from the grommet; read W/D (211) under True Index.

7. Count speed circles between grommet and head of resultant to get W/F (34K).

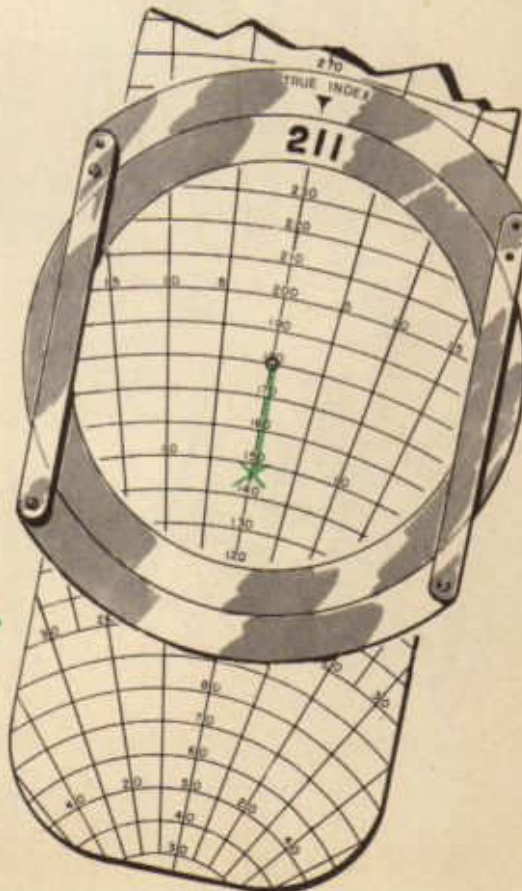

TYPE III

- Given: 1. One factor (TAS) of first component velocity.
2. Second component velocity (W/v).
3. One factor (Tr) of resultant velocity.

Required: TH and GS.

Problem

- Given: 1. TAS = 160K
2. W/v = 020/25K
3. Tr = 109

Required: TH and GS

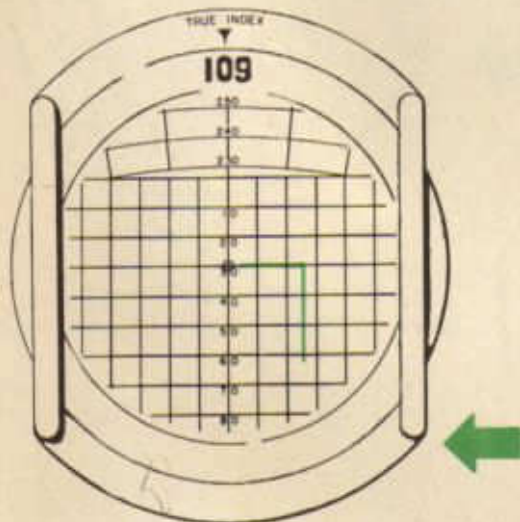
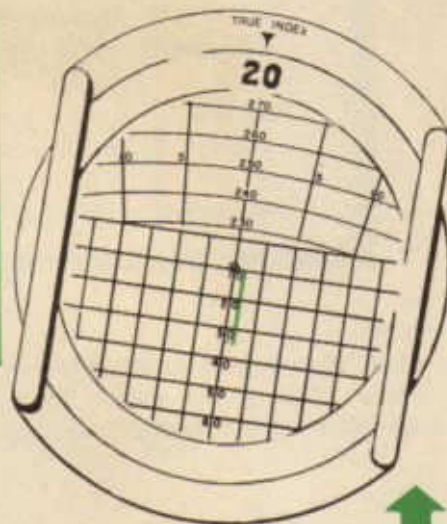

Procedure:

1. Place square grid under plate.
2. Place W/D (020) under True Index and draw W/F (25K) down from grommet.

3. Place Tr (109) under True Index.
4. Draw Tr up a vertical line to head of wind.

5. Place circular graph under plate and place TAS (160) under grommet.
6. Align track with radiating lines.
7. Read TH (100) under True Index.
8. Read GS (158K) on speed circle at head of resultant (Tr-GS) vector.

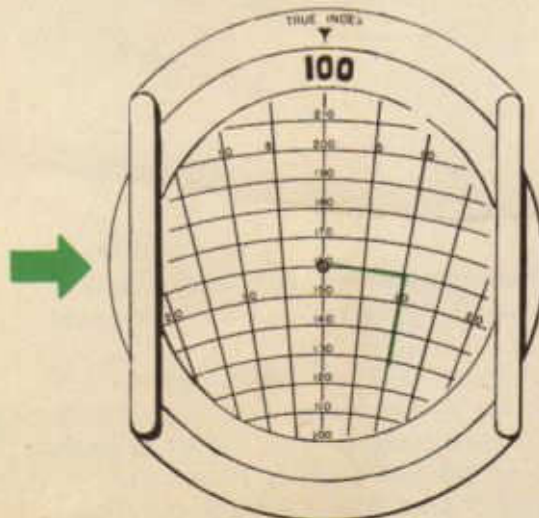

TYPE IV

- Given: 1. Second component velocity (W/v)
2. Resultant velocity (TC-GS)

Required: First component velocity (TH-TAS)

Problem

- Given: 1. $W/v = 180/30K$
2. $TC = 090$; $GS = 150K$
- Required: TH and TAS

Procedure:

1. Place square grid under plate.
2. Place W/D (180) under True Index and draw W/F (30K) drawn from grommet.
Down

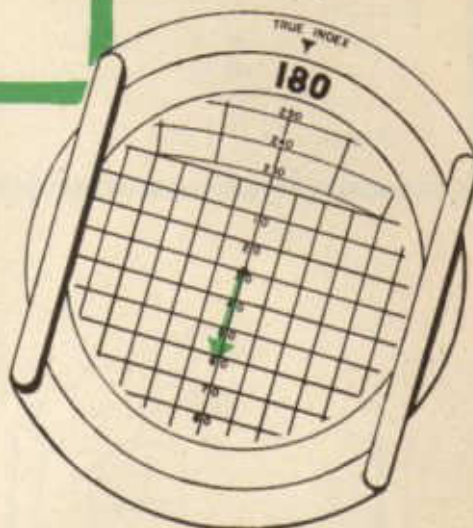
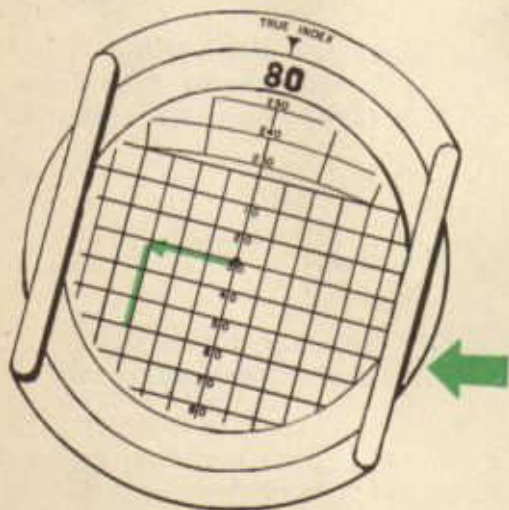

3. Place TC (090) under True Index.
4. Draw TC up a vertical line to head of wind.

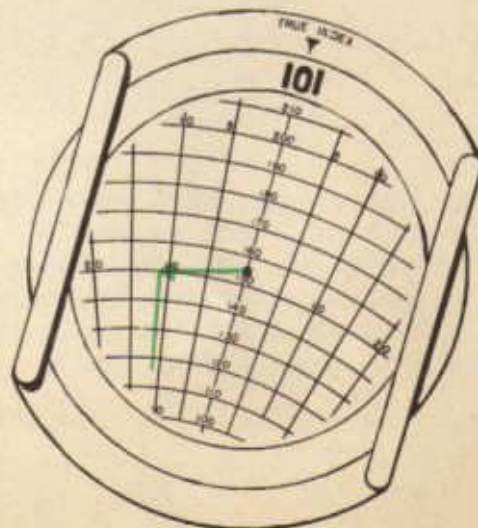

5. Place circular graph under plate and place head of TC vector on GS (150) speed circle.

6. Keeping head of TC vector on 150 speed circle by revolving plate, adjust slide until TC vector aligns with radiating lines.

7. Read TH (101) under True Index.

8. Read TAS (153K) under grommet.

Using Instrument Readings

Precision dead-reckoning, defined as instrument navigation, obviously includes two things: (1) getting information from navigation instruments and (2) using this information. In order to get information from his instruments, the navigator must establish early the habit of reading them methodically and consistently. He must be conscious of them at all times and must note at once any change shown on any one of them. Any change, however small, should be noted, because any change that will affect the instruments will affect the aircraft and, hence, the navigation.

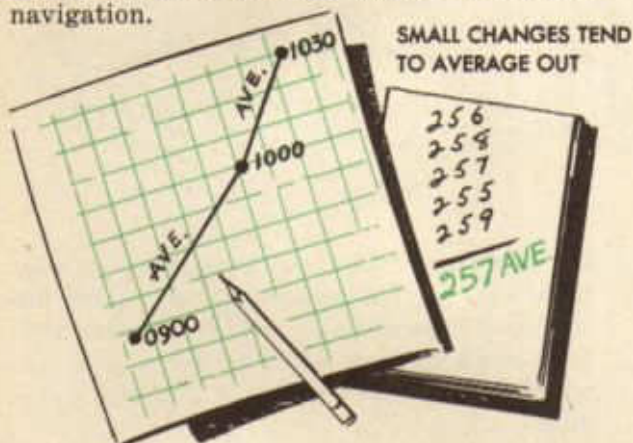

Fortunately, most small changes tend to average out and the navigator merely notes them and averages the readings. This procedure is followed regularly with respect to

all instrument readings. No hard and fast definition of *small changes* can be laid down. The navigator must develop judgment and use common sense. The size of the change is not as important as is the regularity of the change and its tendency to vary as much and as long one way as the other. An air



WHEN READINGS VARY REGULARLY AVERAGE IS VERY ACCURATE

speed that varies regularly from 145K to 155K during an hour can be figured safely as 150K for the entire hour. But an air speed that is 145K for ten minutes and 155K for fifty minutes should not be averaged as 150K for the hour. Obviously, it is better to use 150K for twenty minutes and 155K for forty minutes. Average readings, correctly used, are particularly useful in ascent, descent, and climb phases of a mission.

When a navigator, for some reason, has not been able to read his instruments for a time and discovers a considerable change when he does read them, it is good practice to assume that the change took place at a time midway between the two readings. A navigator, for instance, last read his compass at 2210, at which time he had a compass heading of 097. At 2230 he reads his compass again and finds that he has a compass heading of 108. In the absence of any further information, he should assume that the change in heading took place at 2220. The navigator should exercise every precaution, however, against getting caught in any such predicament.



The navigator will experience little difficulty in keeping track of his free air temperature, since it generally changes very gradually and tends to be consistent. He will find, however, that any definite change in temperature is a warning to check all his readings, because conditions that produce a change in temperature generally produce other more radical changes.

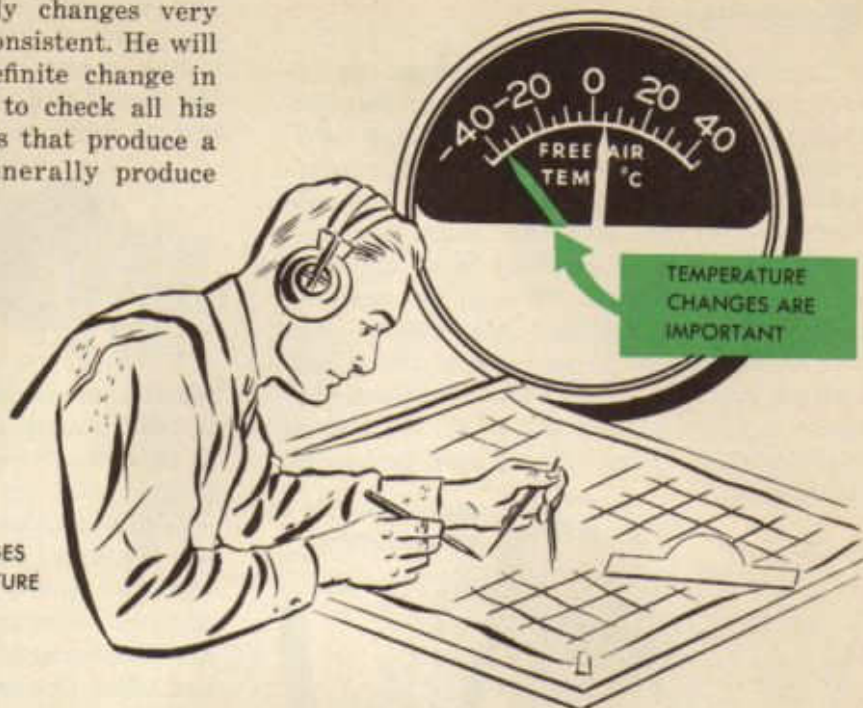

The navigator absolutely must keep up with his altitude if he wishes to keep alive or to keep navigating. It is his definite responsibility to keep check on the absolute altitude and to warn the pilot (1) when the absolute altitude falls below the level set for the mission and (2) when approaching mountain peaks or other obstructions on course. Remember the posters seen around Operations: "ALTITUDE IS LIFE INSURANCE"—the navigator's life as well as the pilot's! As simple as this precaution seems to

be, crews are lost every week because they ignore it. The navigator also must know his corrected true altitude and his pressure altitude at all times in order to figure true air-speed or, in other words, in order to navigate.

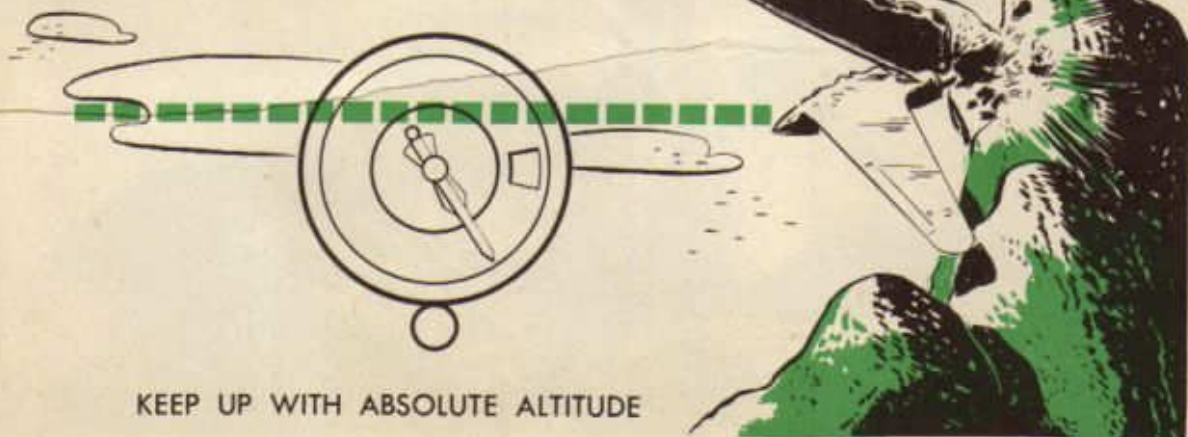

The navigator must keep one of his many eyes on the compass at all times and another on his airspeed meter. From his compass he gets information to figure his TH; from his airspeed meter he gets information to figure his TAS. From these (TH-TAS) he gets the information for the first component vector (TH-TAS) of all his vector triangles. Combining these two (TH-TAS) with time, he gets his *air position*, that is, where he would be if there were no wind. Many navigators

keep an *air plot* (a record on the chart of their air position) by plotting the TH-TAS's flown. Such an air plot is not hard to keep, since TH, TAS, and time, the only information required to keep it, are obtained inside the aircraft and are available to the navigator at all times.

While an air plot will not give a navigator all the information he needs, a navigator with an accurate air plot is very hard to lose. In fact, the air position is so important that an instrument, the *Air Position Indicator* (API), has been developed and installed in many aircraft. The coordinates of departure point may be set on the API and thereafter it indicates the coordinates of the air position of the aircraft.

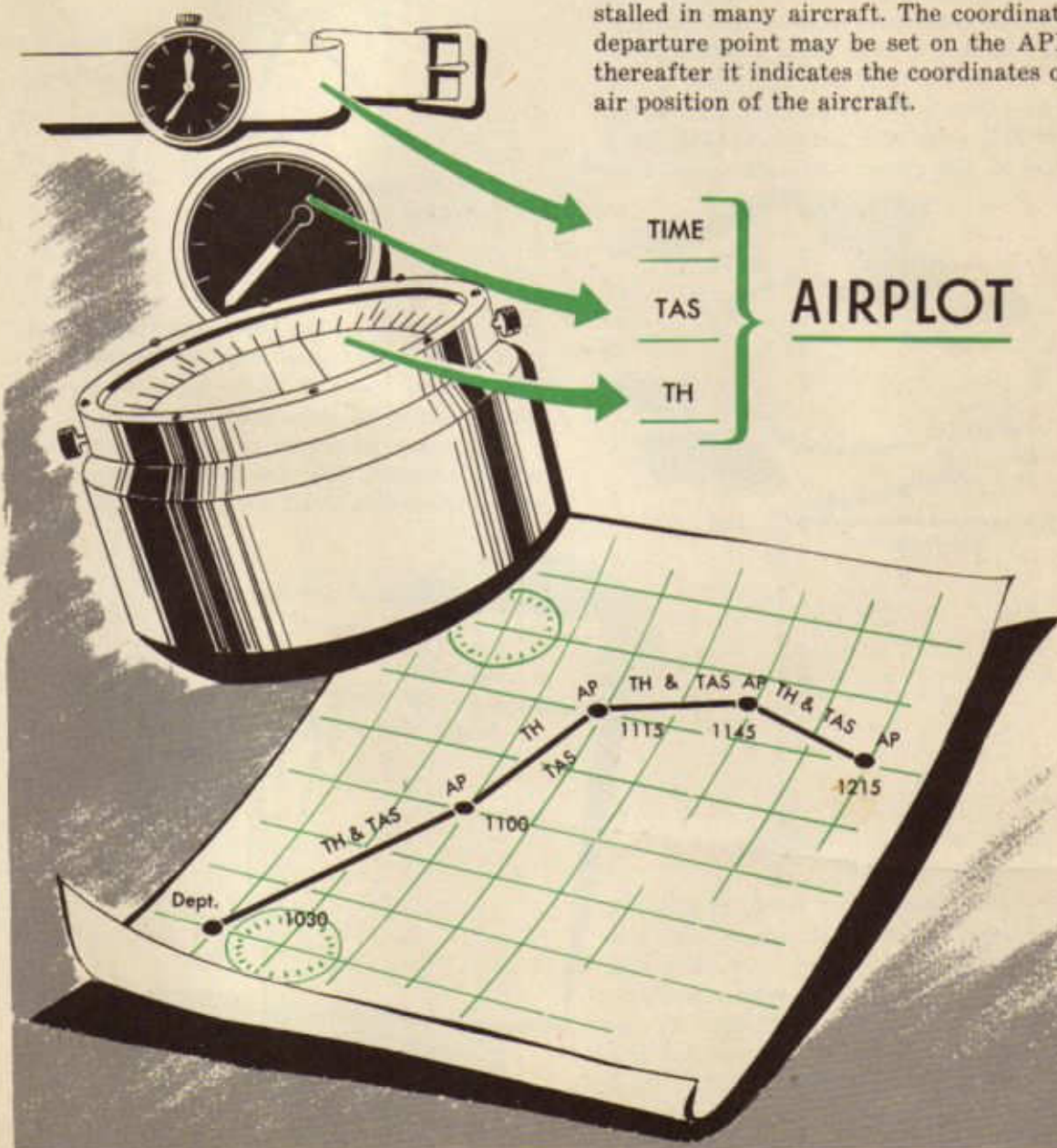

Finding the Wind

The question, "What is the wind?", continually plagues the navigator. The wind is the great variable in air navigation. A good navigator never trusts the wind, but continually checks it. Many methods of wind-finding are available, the most common of which is called "wind by drift on multiple headings."

If an aircraft flies two or more different headings and the navigator can read drift on each heading, it is possible for him to find the wind. To illustrate, suppose that two aircraft are each 150 NM from a given destination, one being west and the other south. If the first flies a TH of 090 and the second a TH of 360, each with a TAS of 150K, they will meet at the given destination one hour

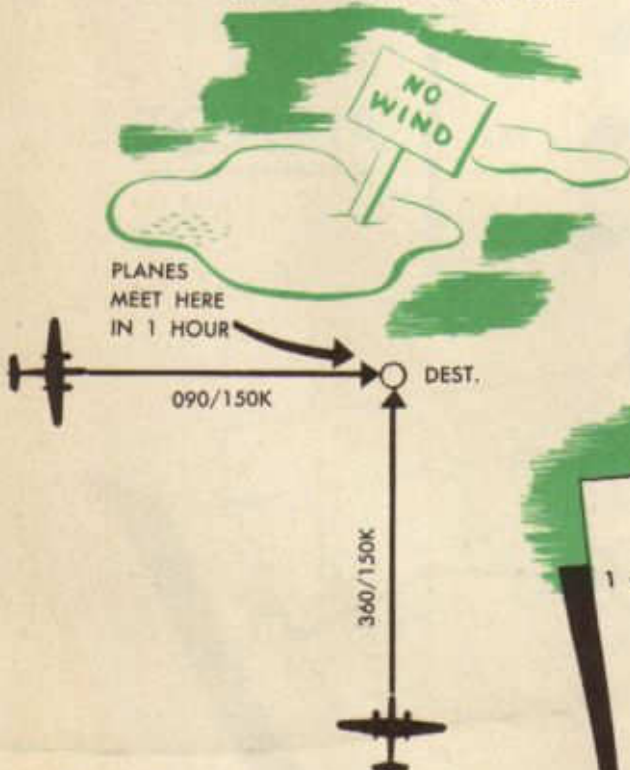

These conditions may be represented by a vector diagram in which the original destination is labeled A, the first aircraft, flying 090/150K, drifts 15R, and the second, flying 360/150K, drifts 15L, meeting at a point labeled B. The wind for the one hour, then,

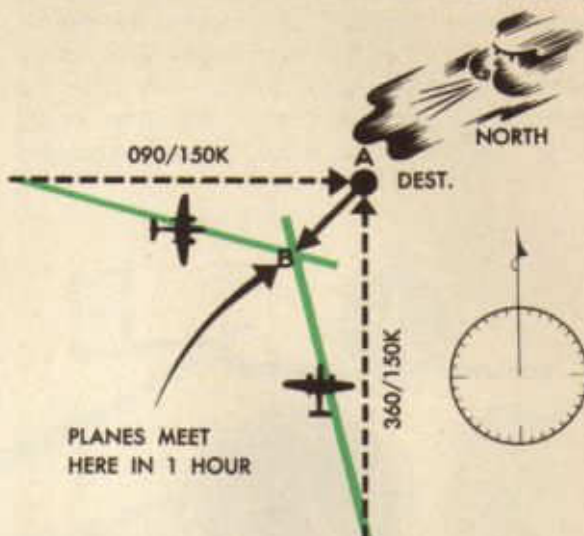

is represented by the line AB, which, when measured, reveals the wind to be 045/45K. The ground speed of either aircraft may be found, of course, by measuring the track.

This same principal is employed when a single aircraft flies two headings and the navigator reads drift on each heading. In

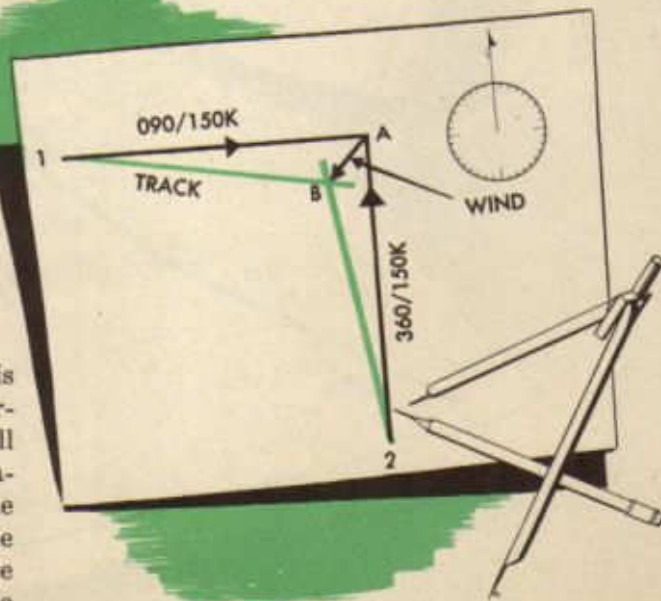

later, *provided* there is no wind. If there is wind, however, it will be acting on each aircraft and at the end of the hour they will meet at a point, but it will *not* be destination. A line drawn *from* destination *to* the point of actual meeting will represent the wind direction and, since both aircraft have been flying for one hour, the length of the line will represent the wind force in knots.

the example cited, if a single aircraft had flown 090/150K and read 15R drift and then had flown 360/150K and read 15L drift, the same diagram could have been drawn and wind found in exactly the same manner. At any time, then, that an aircraft flies two or more headings on which drift can be read, the wind and ground speed on either heading may be found. For example, an aircraft flies 045/150K and drifts 005L, then flies 170/140K and drifts 004R; find the wind and the ground speed on each heading.

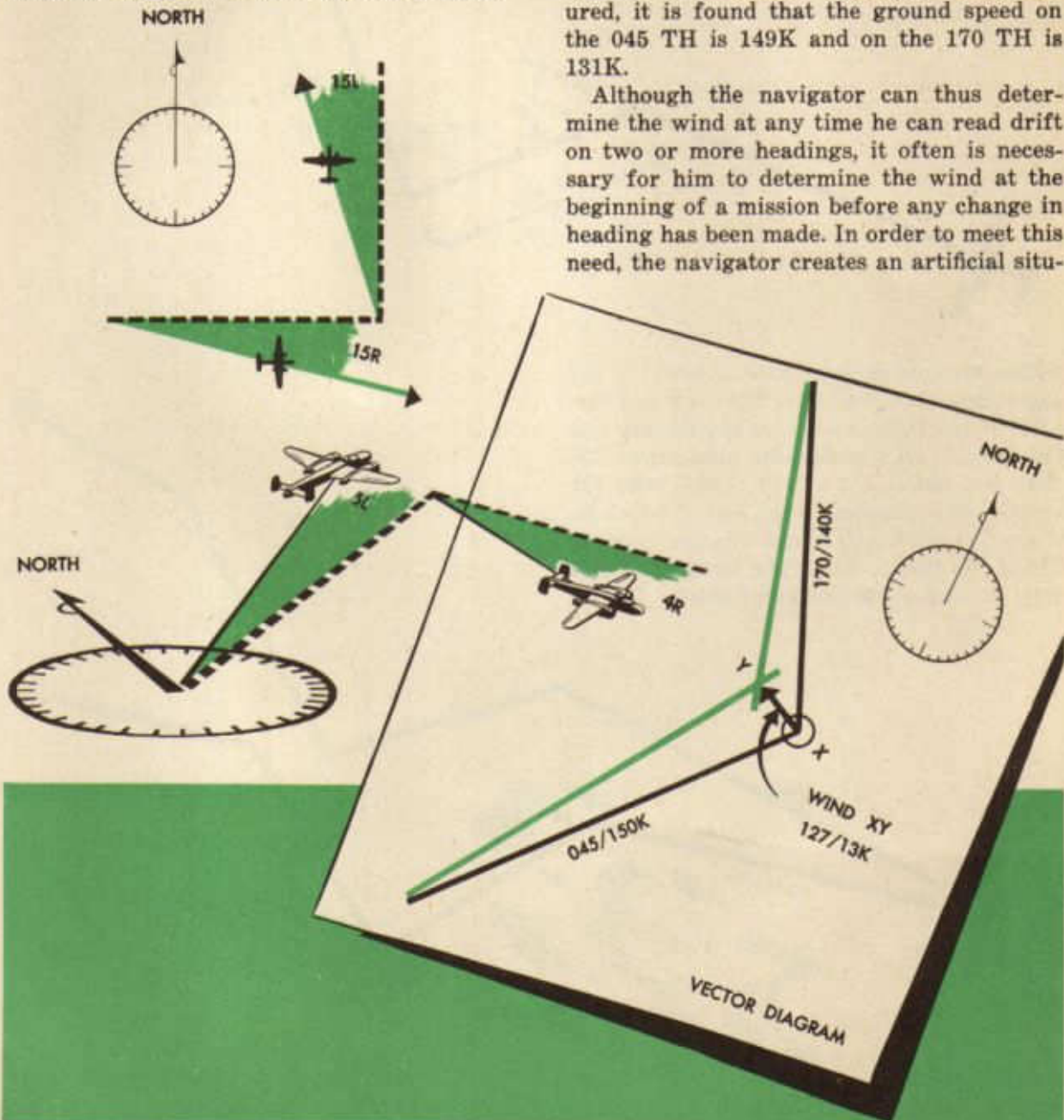

To any point, X, draw the first TH-TAS vector (045/150K) and from its tail, draw the Tr-GS vector 005L of the TH-TAS vector, (045-005), making it somewhat longer than the TH-TAS vector. Then draw the second TH-TAS vector (170/140K) to X in the same manner and draw the second Tr-GS vector 004R (170-004). The two Tr-GS vectors will intersect at some point, Y. The wind, then, is represented by the line XY and, when measured, is found to be 127/13K. When the respective Tr-GS vectors are measured, it is found that the ground speed on the 045 TH is 149K and on the 170 TH is 131K.

Although the navigator can thus determine the wind at any time he can read drift on two or more headings, it often is necessary for him to determine the wind at the beginning of a mission before any change in heading has been made. In order to meet this need, the navigator creates an artificial situ-

ation by flying a *double drift*, which is merely a specialized case of wind by drift on multiple headings. The technique of the double drift may best be explained by following through an example.

An aircraft is flying a TH of 090 at the beginning of a mission and the navigator must find the wind. He instructs the pilot to fly a double drift at a stated time, probably

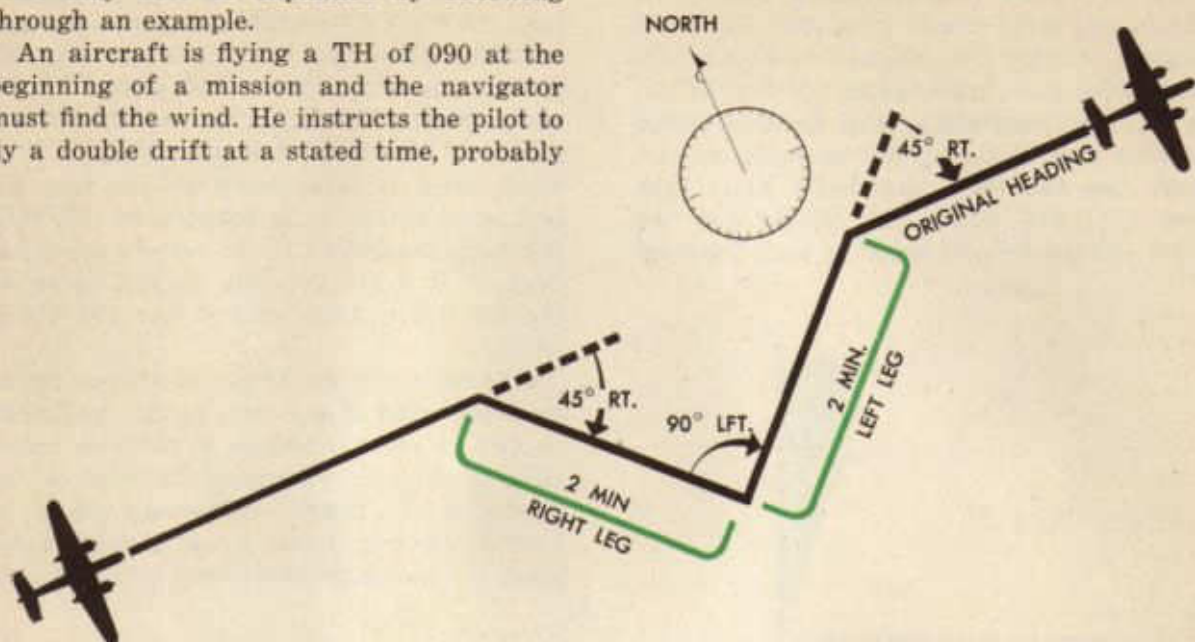

within the next three or four minutes. At the stated time the pilot alters TH 045R and flies a TH of 135 ($090 + 045$) for two minutes. At the end of two minutes, the pilot alters TH 090L and flies a TH of 045 ($135 - 090$) for another two minutes, at the end of which he alters TH 045R and again flies the original TH of 090 ($045 + 045$). The navigator reads drift on each of the headings flown.

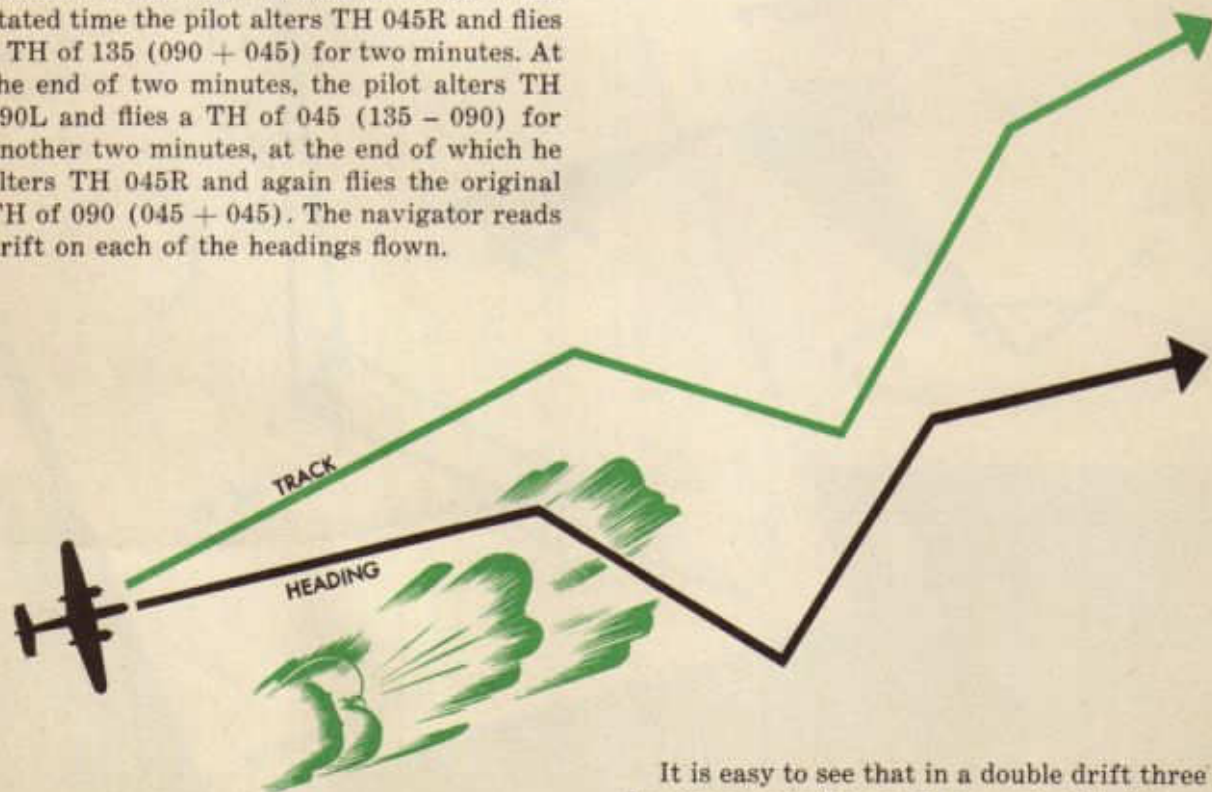

It is easy to see that in a double drift three headings actually are flown and, if drift has been read on each heading, the TH's and the

Tr's can be plotted to find the wind. Consider a typical problem:

Given:

1. On-course heading 060/130K, drift 005L.
2. Drift on right leg 006R.
3. Drift on left leg 011L.

Required:

1. Wind.
2. GS on course.

Procedure:

Draw the three TH-TAS vectors to a common point, X. From the tail of each TH-TAS vector, draw the proper Tr-GS vector by applying the drift. Thus, the on-course Tr is 055 (060 - 005), the right leg Tr is 111 (105 + 006), and the left leg Tr is 004 (015 - 011). These Tr's will intersect, either at a point or, more usually, in the form of a small triangle, at Y. The center of the small triangle is taken as the head of the wind, and the line XY, when measured, gives the wind, in this case, 080/26K. Measuring the on-course Tr gives the required GS, 106K.

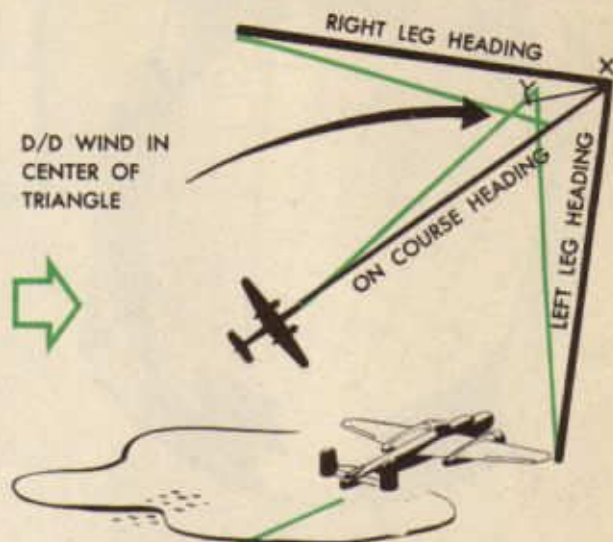

CHECK COMPASS ON EACH HEADING OF D/D

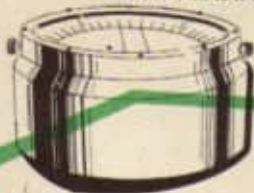

One word of warning concerning double drifts should be noted. The navigator should not assume that the pilot will turn exactly 45 or 90 degrees when flying a double drift, but should check each TH by his compass as it is being flown. He should plot the exact TH flown on each leg if he expects to find the wind accurately. The navigator must be very careful, also, to remember that the driftmeter gives a reading of *drift correction*; the signs must be reversed to give drift!

Both the general problem of wind by drift on multiple headings and the specialized problem of wind by double drift are easily set up and solved on the E-6B computer. In order to avoid confusion that might arise

because of the driftmeter's reading drift correction instead of drift, the navigator should take a sharp instrument and scribe a plus (+) on his computer under the word *left* in the phrase *drift left* on the left side of the True Index and a minus (-) under the word *right* at the corresponding position to the right of the True Index.

These signs will serve to remind him to draw in plus drift correction to the left of the center line and minus drift correction to the right.

SCRIBE A (+) AND A (-) ON COMPUTER - FOR DRIFT CORR.



Consider the following wind by drift on two headings problem:

Given:

1. First heading 045/150K, drift correction +005
2. Second heading 170/140K, drift correction -004

Required:

1. GS on second heading.
2. Wind.

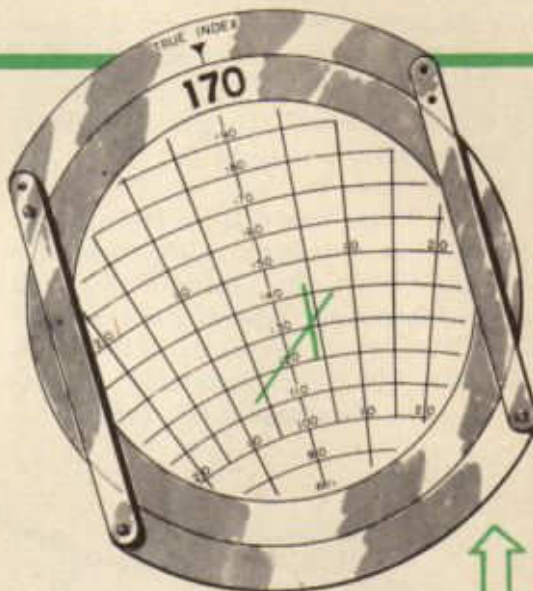
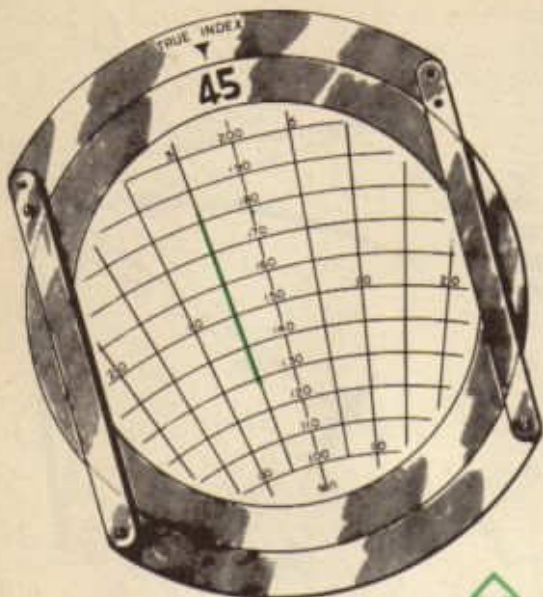

Procedure:

1. Set up first heading (045/150K): 045 under True Index and 150 under grommet.
2. Draw in drift correction on first heading (+005): locate the radiating line five degrees to the *left* (toward the scribed *plus*) of the center line and draw a line over it on the plate.

3. Set up second heading (170/140K): 170 under True Index and 140 under grommet.

4. Draw in drift correction on second heading (-004): locate the radiating line four degrees to the *right* (toward the scribed *minus*) of the center line and draw a line over it on the plate. This line will cross the first line drawn.

5. Read GS on second heading (131K) at intersection of lines.

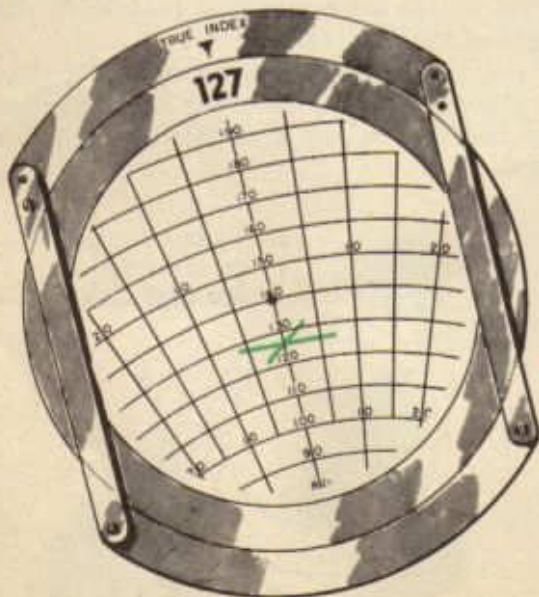

6. Align intersection of lines drawn with the center line *down from* the grommet. Read wind direction (127) under True Index and wind force (13K) on the center line, counting speed circles from grommet to intersection.

The wind by double drift problem is solved on the E-6B computer in much the same way as the problem above was solved. The navigator should remember that the center line on the card represents the longitudinal axis of his aircraft; therefore when the aircraft flies a right leg, he turns the center line to the right, etc.

He should note also that the drift scale on the computer frame extends 45 degrees on either side of the True Index. This is for his convenience in solving the double drift problem. As the pilot turns on the right leg, the navigator can turn the center line until the on-course TH falls under the 45 degree mark to the left of the True Index. The right leg TH then is under the True Index, where it can be checked against the TH actually being flown and any difference corrected.

When the pilot turns 90 degrees left, on the left leg, the navigator turns the center line left until the on-course TH comes up under the 45 degree mark to the right of the True Index. The left leg TH then is under the True Index, where it can be checked and corrected if necessary. When the pilot turns right, back on course, the navigator again places the on-course TH under the True Index, checks, and corrects if necessary. On the right and left leg headings, the navigator corrects his computer, not the pilot; on the final on-course heading, he corrects the pilot, not the computer.

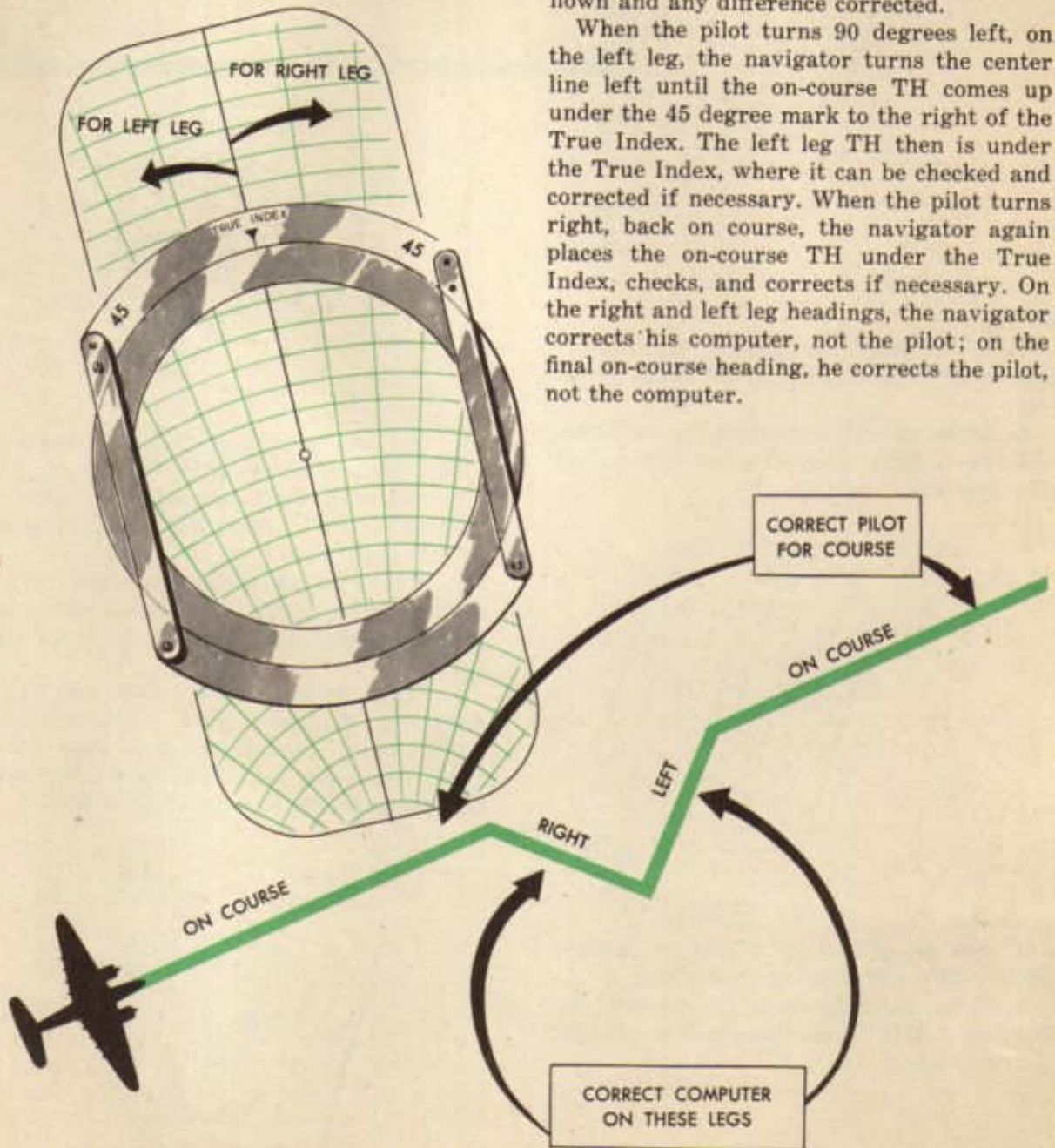

Consider the following typical wind by double drift problem:

Given:

1. On-course heading 060/130K, drift correction +005
2. Right leg drift correction -006
3. Left leg drift correction +011

Required:

1. GS on course
2. Wind

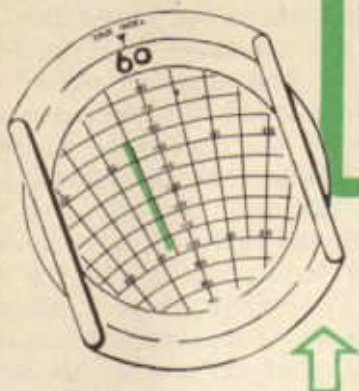

Procedure:

1. Set up on-course heading (060/130K): 060 under True Index and 130 under grommet.

2. Draw in drift correction for on-course heading (+005): draw line five degrees left of center line.

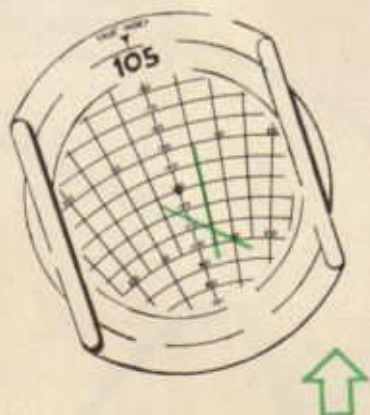

3. Set up and check right leg heading (060 + 045 = 105) as outlined above.

4. Draw in drift correction on right leg heading (-006): draw line six degrees right of center line.

5. Set up and check left leg heading (105 - 090 = 015) as outlined above.

6. Draw in drift correction on left leg heading (+011): draw line eleven degrees left of center line.

7. Re-set on-course heading (060/130K) as in 1 above, check, and read on-course GS (106K) at center of triangle on speed circles.

8. Align triangle with center line *down* from the grommet. Read wind direction (080) under True Index and wind force (26K) on center line, counting speed circles between grommet and center of triangle.

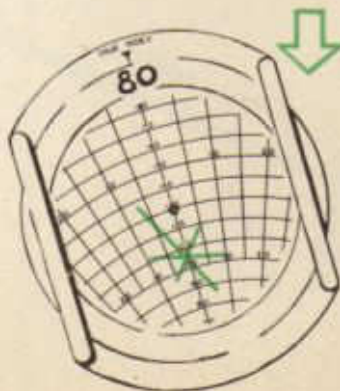

Using the Wind

Having found the wind, the navigator makes use of it to find (1) his track, (2) his groundspeed, and (3) his ground position (GP). If he is keeping an air plot, he merely draws a vector representing the effect of the wind for the length of time represented by the air plot *down from* his air position. The

head of this wind vector indicates the ground position, a line drawn from the tail of the TH-TAS vector to the GP (head of the wind vector) represents the exact groundspeed and track if only one TH-TAS has been flown, or it represents the average groundspeed and track if more than one TH-TAS has been flown.

If the navigator is not keeping an airplot, he uses the wind to solve wind triangle problems, either graphically or on his computer, to find the track and groundspeed as each TH-TAS is flown. He plots the track on his

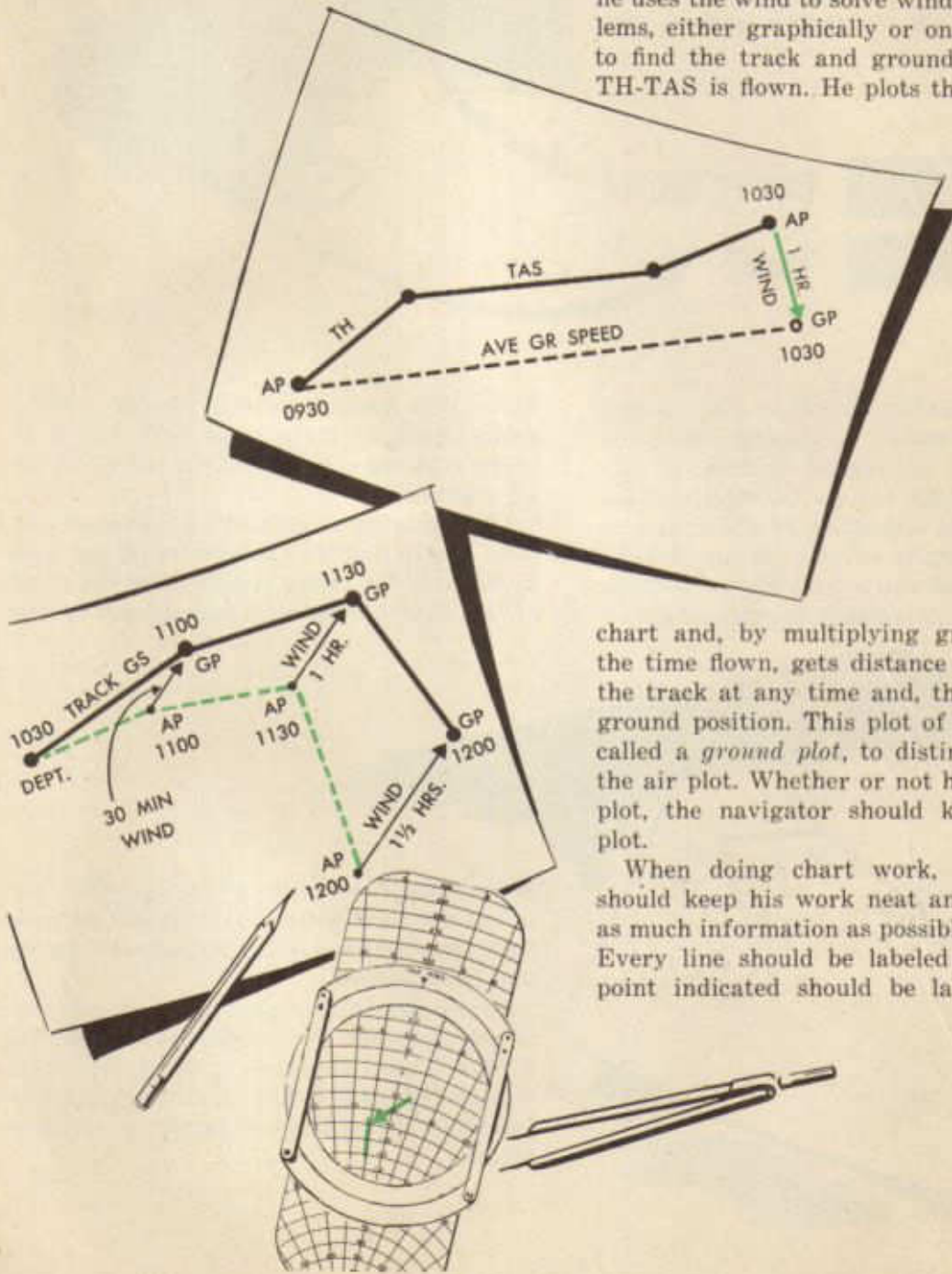
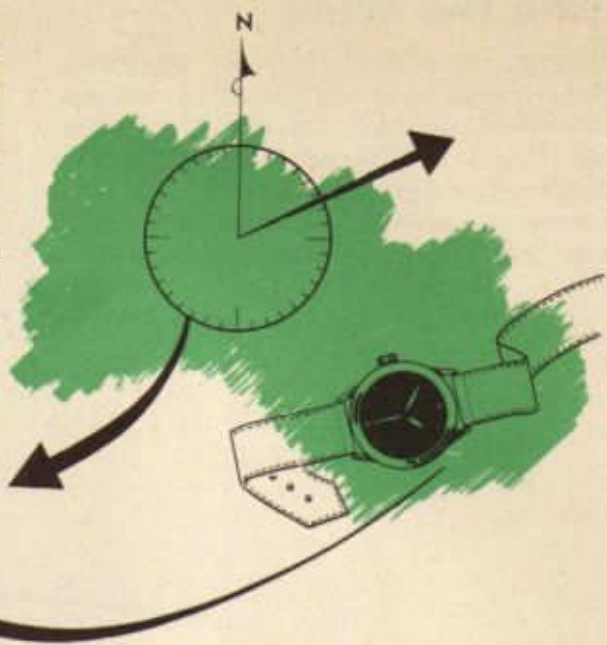

chart and, by multiplying groundspeed by the time flown, gets distance made good on the track at any time and, thus, figures his ground position. This plot of TR and GS is called a *ground plot*, to distinguish it from the air plot. Whether or not he keeps an air plot, the navigator should keep a ground plot.

When doing chart work, the navigator should keep his work neat and should keep as much information as possible on the chart. Every line should be labeled neatly; every point indicated should be labeled and the

time noted. True direction should be indicated always by three numerals (068); magnetic or compass directions, by three numerals followed by the letter *M* or *C* (090 M; 086 C). Time of day always is indicated on a 24-hour basis in four figures (1348); elapsed time, by hours, minutes, and seconds (3^h 45^m 30^s).

It is not necessary to keep *only one* plot on the chart. If possible, the navigator should keep *both* an air plot *and* a ground plot,



checking one against the other. The navigator should be skilled at keeping and using either or both. He should be able, at any time, to find both his air position and his ground position, regardless of which plot he is keeping. If he is keeping an air plot, he can lay the wind *down from* his air position to find the ground position, as outlined above.

From that ground position he can start a ground plot, an air plot, or both. Or, if he prefers, he can continue his air plot from the air position.

If the navigator is carrying a ground plot only, he can find his air position at any time by drawing the vector representing the effect of the wind for the time represented by the

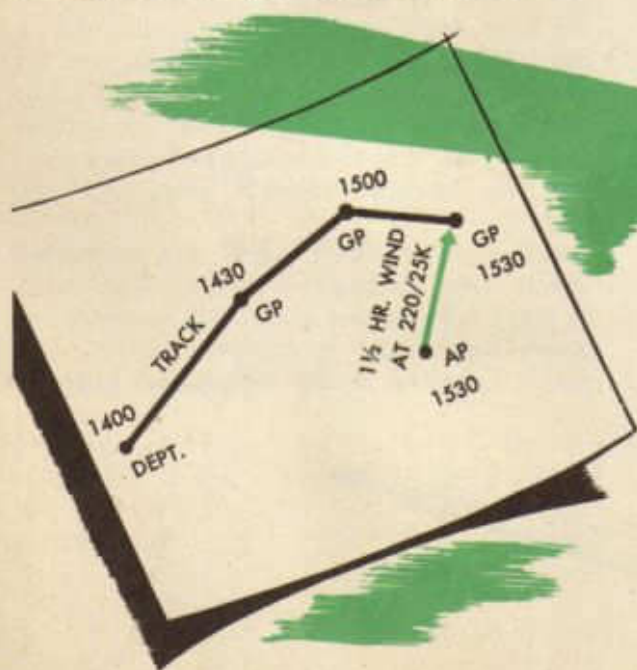

ground plot *down to* the ground position; the tail of the wind vector indicates the air position, from which position he can start an air plot if he wishes.

From an accurate plot, either an air plot or a ground plot, the navigator can calculate ETA's, correct headings, or do anything that will be required of him. An inaccurate plot is a snare that will mean disaster to any navigator.

DEAD-RECKONING PROCEDURE

Dead-reckoning is the art of determining where an aircraft is or where it will be at a given time by figuring where it must be at that time because of the distance and direction flown from a known position. Precision dead-reckoning employs six navigation instruments: (1) altimeter, (2) free air temperature gauge, (3) compass, (4) airspeed meter, (5) clock, and (6) driftmeter. These instruments yield information necessary for keeping up with (1) the altitude, (2) the heading, airspeed, and air position, (3) the effect of the wind, and (4) the track, ground-speed, and ground position.

The navigator is most interested in knowing his track, groundspeed, and ground position. These he can find in either of two ways: (1) by keeping an air plot and applying the effect of the wind to the air position at any given time to find the ground position at that time, or (2) by keeping a ground plot. Either method has certain advantages and disadvantages. The navigator will use the method which best meets the needs of the

moment. He should be able to use either method and to go from one to the other at any time.

Before any flight, the navigator should check all the instruments to see that they are properly calibrated and should see that all calibration cards are in their proper place. He will see that all clocks in the aircraft are synchronized. He will set the altimeter on *altimeter setting* and will find out the proposed flight altitude. He will have determined the TC between departure point and destination, and, by working from TC to CH,

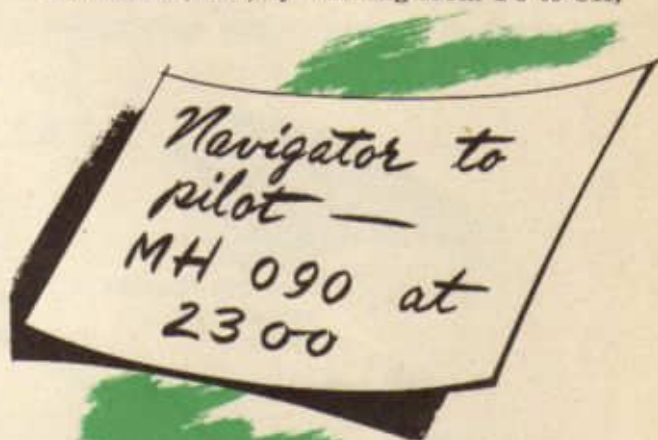

CHECK ALL
INSTRUMENTS
BEFORE
EACH FLIGHT



will determine the desired CH. He may or may not have computed a drift correction on the basis of metro winds in arriving at this CH. He will give the pilot the *MH*, not the *CH*.

Many missions leave departure point at flight altitude. It is the navigator's responsibility to make sure that departure is made from the proper point and to record the time of departure. Immediately after departure, the navigator must do three things: (1) obtain drift reading, (2) work from TC to CH, using the drift correction found, and (3) correct the pilot to the left or right until the compass reading checks with the desired CH. The aircraft then is making good the desired course. Failure to do these things

within the first two or three minutes of the flight lessens materially the chances for a perfect mission. The navigator must realize that the secret of hitting destination is in getting the pilot on course and in constantly checking to see that he stays there.

As soon as the aircraft is on the proper heading, the navigator checks the on-course drift and determines the true altitude and the TAS. After he has done this, he must find the wind, usually by flying a double drift. He must be careful in solving the double drift (1) to use the exact TAS and (2) to use the exact angles turned. Having found the wind, the navigator can use it to find the ground-speed. Knowing the groundspeed, he can calculate ETA's and can perform any of the tasks required of him. He must realize, always, that changes which will affect the final results of the mission may occur at any

time. He must check all his instruments systematically in order to catch such changes as they occur and to correct for them.

When an aircraft climbs or descends, it is almost sure to pass through varying winds at different levels of flight. Unless the pilot is climbing very steadily with the aircraft well trimmed, both drift and airspeed readings are inaccurate. Through a climb or descent, therefore, the navigator has no way of knowing what the wind is. If he has been flying with a known drift correction, he should continue the same heading until level-off. If he climbs on-course at take-off, he generally uses TC for TH until he reaches flight altitude. In either case, he uses the TAS found by applying the average temperature and pressure altitude to the average IAS to find ground speed. He considers each level-off position as a new departure point.

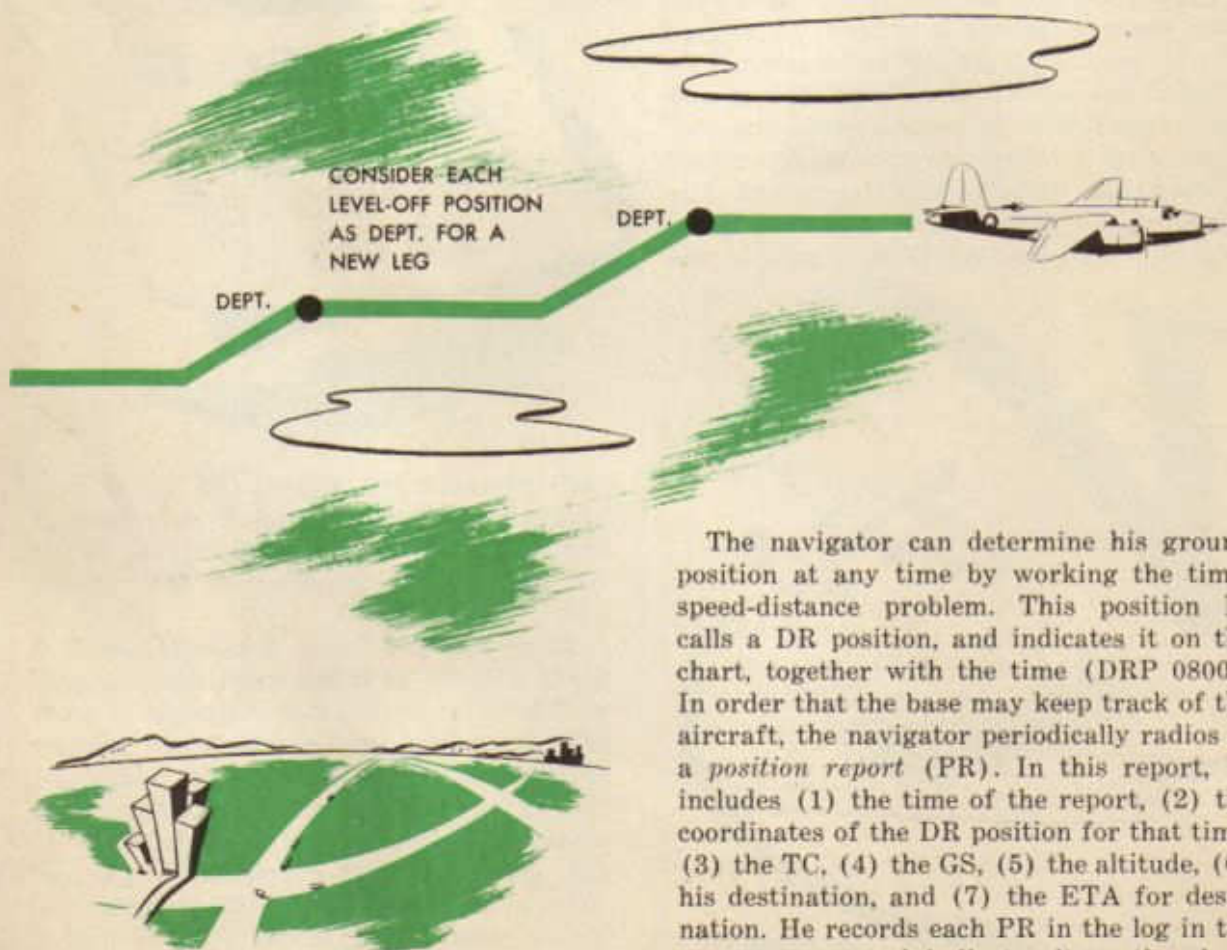

The navigator can determine his ground position at any time by working the time-speed-distance problem. This position he calls a DR position, and indicates it on the chart, together with the time (DRP 0800). In order that the base may keep track of the aircraft, the navigator periodically radios in a *position report* (PR). In this report, he includes (1) the time of the report, (2) the coordinates of the DR position for that time, (3) the TC, (4) the GS, (5) the altitude, (6) his destination, and (7) the ETA for destination. He records each PR in the log in the proper space and indicates it on the chart together with the time (PR 0850).

159-131

One of the best aids to good navigation is a systematic and neat record of the navigator's work. A good log will save a navigator's time, effort, and reputation. The large number of calculations which he must make, he cannot possibly keep in his head. He must write them down and, since he must write them somewhere, he might as well write them neatly and in some order. He should avoid using scraps of paper. The log sheet provides him with a place for every piece of information that he will need. Once he properly places the information on the log sheet, he will not have to waste time looking through crumpled bits of paper for vital figures.

KEEP A LOG!

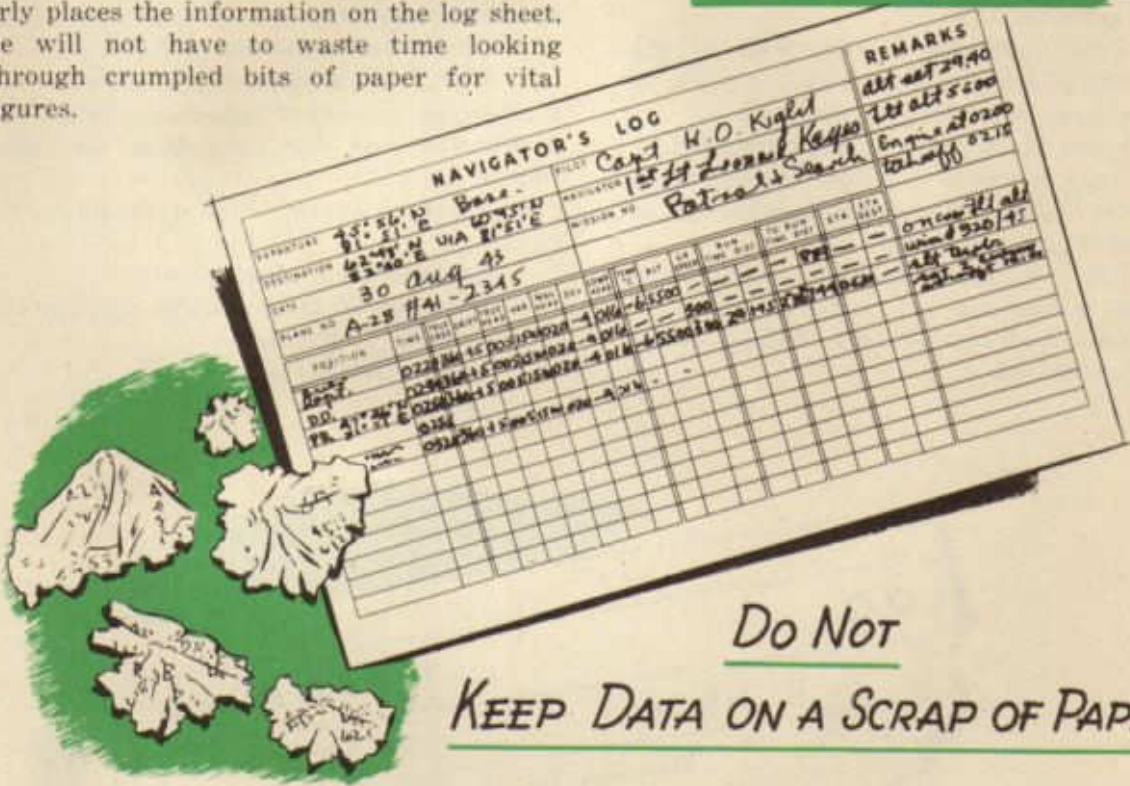

Do Not KEEP DATA ON A SCRAP OF PAPER

The navigator's log should tell the complete story of the flight in such a manner that not only the navigator himself, but also any other suitably trained person can understand it. If the navigator is injured, some other member of the crew must take over his duties. That other crew member must be able to see what the navigator has done by looking at the chart and the log. For that reason, the navigator must keep the chart up-to-date and clear, and he must follow a standard procedure in keeping his log.

The navigator can tell where to put various items on his log sheet by looking at the

- sheet. These rules generally are followed:
1. Enter names of places in the position column NEATLY. Indicate position reports, and enter the coordinates.
 2. Reckon time on the 24-hour clock system. Make time entry for any remark in the *remarks column*, even if no other entries are made. Make a double entry of time for any alteration of course, with entries of previous and new true course, drift correction, true heading.
 3. Express all courses, headings, and azimuths as three-figure groups; e. g., 002, 026, 173.

4. Enter true course only at the beginning of a leg, at the end of a leg, and alteration of course, and at the time D.R. positions are recorded.

5. Express drift correction in degrees preceded by a plus (+) or minus (-) sign. Record only when a change occurs or when there is reason for another entry of time.

6. Enter true heading only when changes occur.

7. Enter variation in degrees preceded by a plus (+) sign for West or a minus (-) for East variation.

8. Enter magnetic heading only at the beginning of a leg or when a D/D is made or when change of heading is required.

9. Enter deviation in degrees preceded by a plus (+) or minus (-) sign as taken from the proper column of the deviation card or as calculated by other means.

10. Enter compass headings only when changes in headings are required.

11. Record all temperature changes in the column provided.

12. Enter Indicated Altitude at frequent intervals and when changes occur.

13. Record Indicated Airspeed whenever other observations are made or when the airspeed changes. Calibrated and true airspeed need not be computed except when required.

14. *Drift* columns usually are provided for recording drift on the right and left legs of a double drift.

15. Wind columns are provided for entry of wind direction and force.

16. The *Run* columns provide space for recording computed or measured increments of distance-made-good along the track.

17. The *To Destination* columns are used for keeping account of remaining distance to destination and for computing estimated time of arrival.

18. In the *Remarks* column should be recorded:

- Remarks about check points
- Indication of double drifts and ground-speeds by timing
- Position reports sent

LOG					REMARKS	
Day C. D. Stones					alt Set. 29.52	
APT X. J. Manasta					Engine St 1545	
cision D.R.					take off 1558	
					meteo Wind 320/16	
					controll GS @ 250	
GR SPEED	RUN TIME	DIST	TO RUN TIME	DIST	ETA	ETA DEST
			826			
					1925	
					desc use @ set alt.	
					alt. tabl.	
					RTLEW +6	
					IFTLEW -110	
					PR to Base	
					gt. speed timing 250	

USE REMARKS COLUMN

Alterations or changes of course
 Data for interception and radius of action
 Record of magnetic compass checks by astro-compass
 Engine starting time
 Watches synchronized, etc.

The following problem illustrates the type of work that the navigator encounters on

simple dead-reckoning missions. The navigator would find the information given in the problem from his instruments in flight. He would have to work out the answers to the requirements. The answers are given here, underlined, after each numbered requirement. The chart and log sheet illustrate what the navigator would have on his chart and log at the conclusion of the mission.

Given:

PLANE: B-34, No. 82-4693

DATE: Today

DEPARTURE: $19^{\circ}27' S-140^{\circ}10' E$ Via
 $19^{\circ}57\frac{1}{2}' S-142^{\circ}45' E$

DESTINATION: $21^{\circ}50' S-141^{\circ}25' E$

MISSION ORDERS: Dog-leg Flight IAS
 215, F/A 15,000'

METRO WINDS: 318/23K at 15,000'

CREW: Roberts, J. R., 1st Lt., Pilot.
 Porter, B. B., 2nd Lt., Co-Pilot.
 (Yourself), Navigator.
 Puffett, Buster, S/Sgt., Crew Chief.

VARIATION: 22 E

ALTIMETER SETTING: 29.90

ENGINES START: 0847

TAKE-OFF: 0852

The navigator finds these cards in the aircraft.

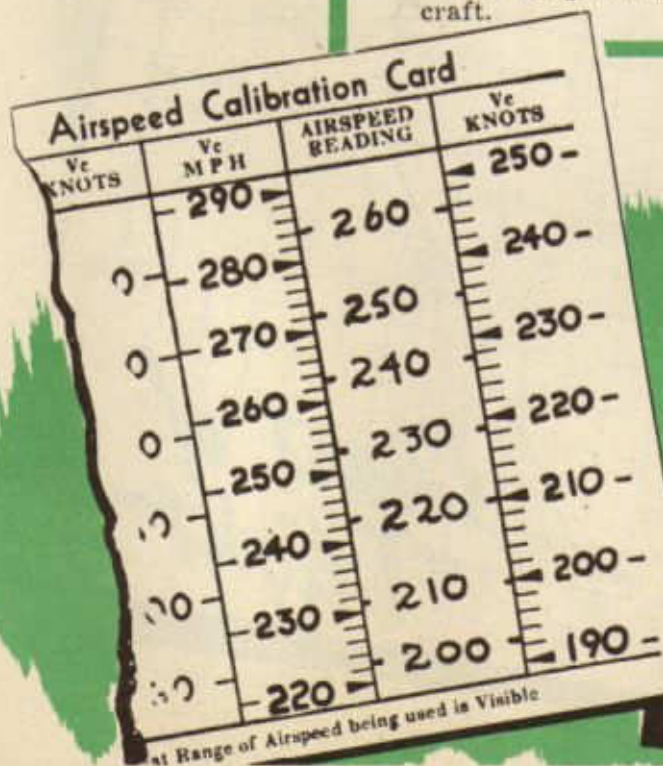

Aircraft Comp.	Date 1/2/44	
C to M		M to C
+1	000	-1
+ $\frac{1}{2}$	045	- $\frac{1}{2}$
0	090	0
- $\frac{1}{2}$	135	+ $\frac{1}{2}$
-1	180	+1
- $\frac{1}{2}$	225	+ $\frac{1}{2}$
0	270	0
+ $\frac{1}{2}$	315	- $\frac{1}{2}$

Required:

1. True Course to turn: 102
 2. Distance to turn: $149\frac{1}{2}$ NM
 3. True Course from turn to destination: $213\frac{1}{2}$
 4. Distance from turn to destination: $135\frac{1}{2}$ NM
- During the climb estimated temperature at F/A: 0°
5. Magnetic Heading based on Metro wind: 077
- At 0905, Over departure at Flight Altitude
Temp: +1°C, Ind Alt: 15,000, IAS: 214
Compass reading: 077
 6. CAS: 204K
 7. TAS: $264\frac{1}{2}$ K
 8. Deviation Corr: 0

At 0908, Drift Correction: -5

 9. Correction to pilot for drift: 2 L

At 0910, D/D No. 1
Temp: +1°C, Ind Alt: 14,980, IAS: 214,
Compass Heading: 075

- Drift Correction on Course: -5
Drift Correction right leg: $-1\frac{1}{2}$
Drift Correction left leg: -6
10. Wind direction: 338
 11. Wind force: 28K
 12. Groundspeed: 279K
- Cloud formation dead ahead.
- At 0924, Temp: +19°C, Ind Alt: 14,980,
IAS: 214, Drift Corr: +6
 13. Correction to pilot: 11 R

Position report, using last known groundspeed, compass heading: 086.

 14. 0924 Position report: $19^{\circ}44\frac{1}{2}'S-141^{\circ}98'E$
 15. True Heading: 108

At 0927, D/D No. 2
Temp: +19°C, Ind Alt: 14,980, IAS: 214,
Drift Corr: +6

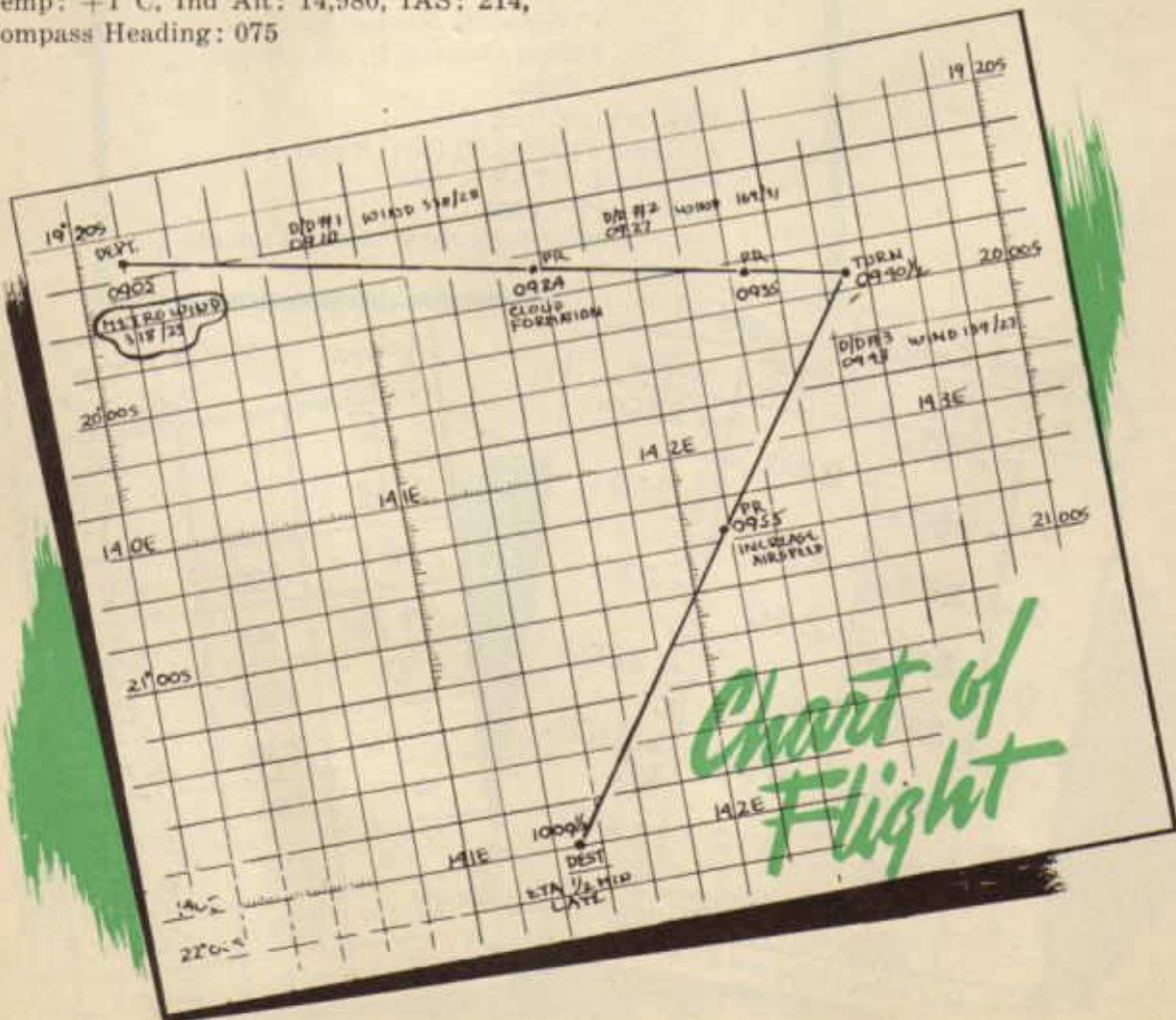

Drift Corr on Course: +6
 Drift Corr on Right Leg: +2
 Drift Corr on Left Leg: +6
 16. TAS: 273 1/2 K
 17. Wind direction: 169
 18. Wind force: 31 K
 19. Groundspeed: 260 K
 At 0935 Position Report to Base.
 Temp: +19°C, Ind Alt: 14,980, IAS: 214,
 Drift Corr: +6
 20. 0935 Position: 19°53'S-142°23'E
 21. ETA to turn: 0940 1/2
 At 0938, send pilot magnetic heading for
 course to destination.
 Temp: +19°C, Ind Alt: 14,980, IAS 214,
 Drift Corr: +6
 22. Magnetic Heading to destination: 187
 23. Deviation correction: +1
 24. Compass Heading: 188

At ETA, turn on new heading.
 At 0943, D/D No. 3
 Temp: +19°C, Ind Alt: 14,980, IAS: 214
 Drift Correction on Course: -4 1/2
 Drift Correction on Right Leg: -5 1/2
 Drift Correction on Left Leg: -1 1/2
 25. Wind direction: 159 1/2
 26. Wind force: 27 K
 27. Groundspeed: 257 K
 At 0955, pilot increases IAS to 260 for better
 engine performance.
 Temp: +19°C, Ind Alt: 14,980, IAS: 260,
 Drift Corr: -4
 28. CAS: 245 K
 29. TAS: 328 K
 30. GS: 311 K
 31. True Heading: 209 1/2
 32. ETA to Dest: 1010
 At 1009 1/2, over destination, close out log.

NAVIGATOR'S LOG															REMARKS			
DEPARTURE	19° 27' S										PILOT							
DESTINATION	140° 10' E VIA 18° 37' S										1st Lt J.R. Roberts		Act set 29.90					
DATE	6/4/44										NAVIGATOR		1st Lt Jay A Singleton					
PLANE NO	B-34 # 82-4693										MISSION NO		Dog Leg					
POSITION	TIME	TRK	CRS	DRIFT	TRK	VAR	MAG	DEV	COMP	TIME	ALT	WIND	CRS	DRIFT	TO RUN	ETA	ETA	
DURK PRPT																		
19° 27' S - 140° 10' E	0905	182	-3	099	226	077	0	077	0	35000	240	318	18	84	14	63	0950	0952
D.R. #1	0910	102	-5	097	228	075	0	075	0	34800	240	318	18	84	14	63	0950	0952
19° 27' S - 141° 25' E	0920	102	-5	097	228	075	0	075	0	34800	240	318	18	84	14	63	0950	0952
D.R. #2	0927	102	-5	097	228	075	0	075	0	34800	240	318	18	84	14	63	0950	0952
19° 27' S - 141° 25' E	0935	102	-5	097	228	075	0	075	0	34800	240	318	18	84	14	63	0950	0952
D.R. #3	0943	102	-5	097	228	075	0	075	0	34800	240	318	18	84	14	63	0950	0952
19° 27' S - 142° 23' E	0955	102	-5	097	228	075	0	075	0	34800	240	318	18	84	14	63	0950	0952
D.R. #4	1009	102	-5	097	228	075	0	075	0	34800	240	318	18	84	14	63	0950	0952
19° 27' S - 142° 23' E	1009	102	-5	097	228	075	0	075	0	34800	240	318	18	84	14	63	0950	0952

SPECIALIZED DEAD-RECKONING TECHNIQUES

Instrument Calibration

DRIFTMETERS

The navigator is responsible for checking the alignment and the trail angle of his driftmeter, and for correcting or reporting any errors found. The alignment is correct if the driftmeter indicates zero drift correction when the reticle drift lines are parallel to the longitudinal axis of the aircraft. The trail angle is correct if the navigator's line of vision through the driftmeter is straight when the line-of-sight control knob is set at zero. Careless handling or rough landings may produce error in either the alignment or the trail angle. Error in alignment causes the driftmeter to indicate inaccurate drift correction readings and incorrect relative bearings. Error in trail angle results in inaccurate estimation of groundspeed by timing.

There are two things to do when aligning the B-2 or B-3 driftmeter, (1) lay a line on the ground under the driftmeter parallel to the longitudinal axis of the aircraft, and (2) adjust the pointer or scale of the driftmeter to read zero when the reticle drift lines are parallel to this line on the ground. Working materials needed are (1) two plumb-bob lines, (2) a long chalk-line and chalk, and (3) a small screw-driver. Do the job in the following manner:

1. Establish the longitudinal axis of the aircraft by dropping plumb-bob lines from the center points of the nose and tail of the aircraft and chalking a line on the ground between the plumb-bobs.

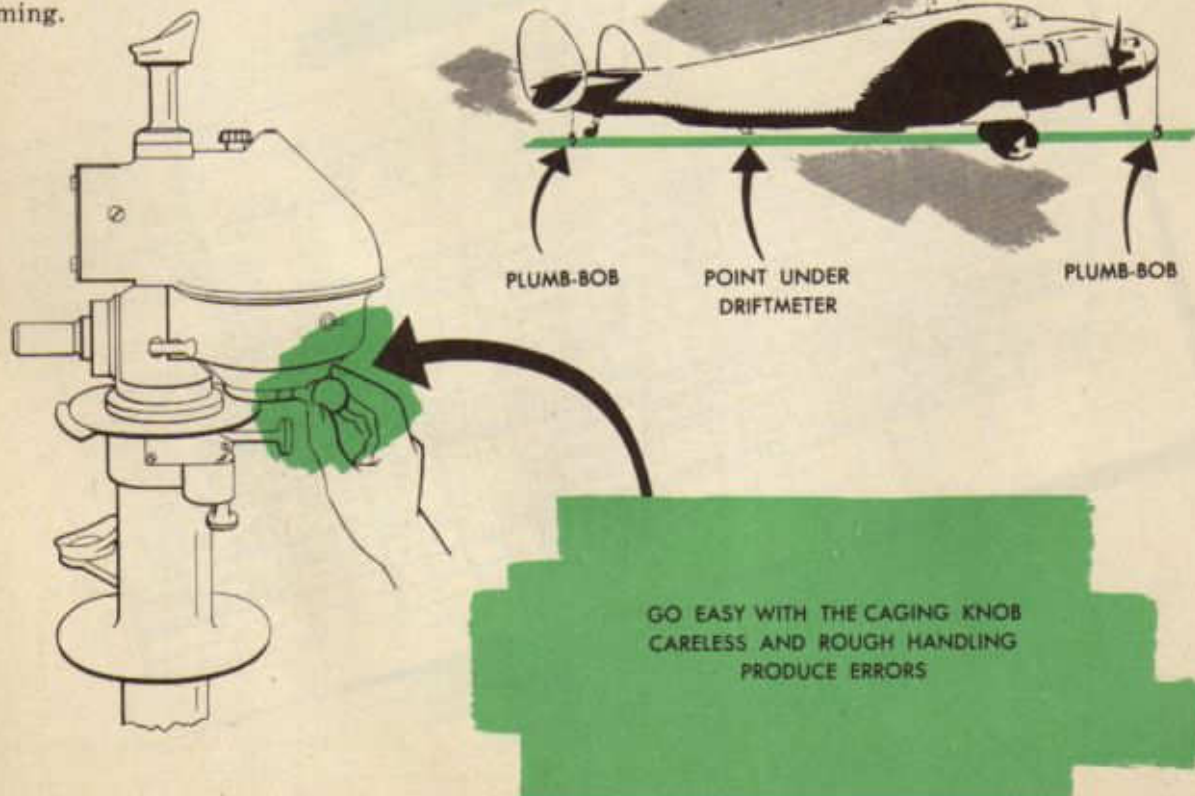

2. Drop a plumb-bob line from the center of the driftmeter to the ground and mark the spot.

3. Lay a line through this spot parallel to the longitudinal axis line, preferably in the manner illustrated.

4. Turn the tangent control knob until the reticle drift lines are parallel to the line on the ground under the driftmeter.

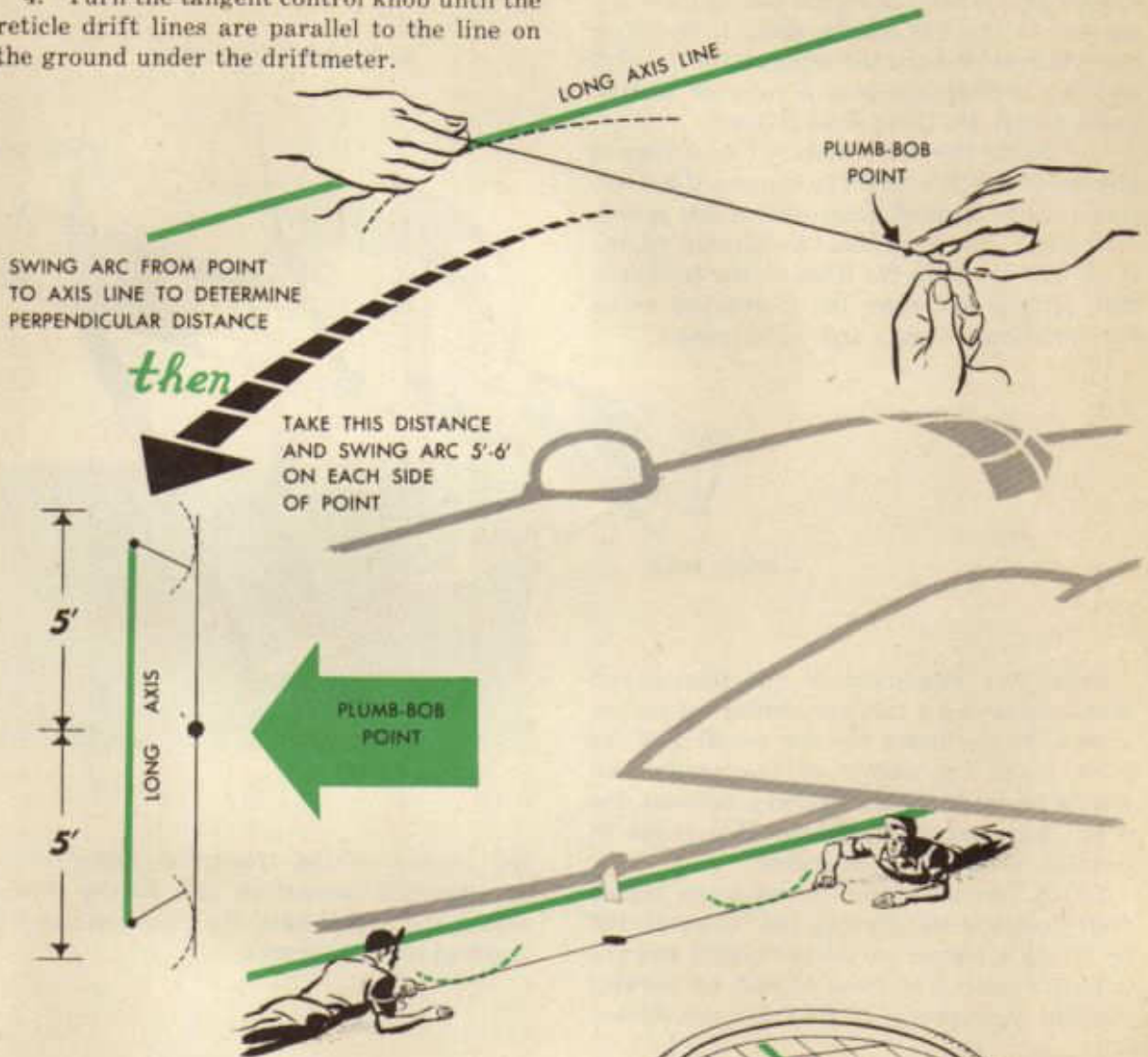

5. Loosen the set-screws holding the drift correction scale (on the B-2) or those holding the pointer (on the B-3), adjust until pointer reads zero; and tighten. Check to see that the reticle drift lines are still parallel with the line on the ground.

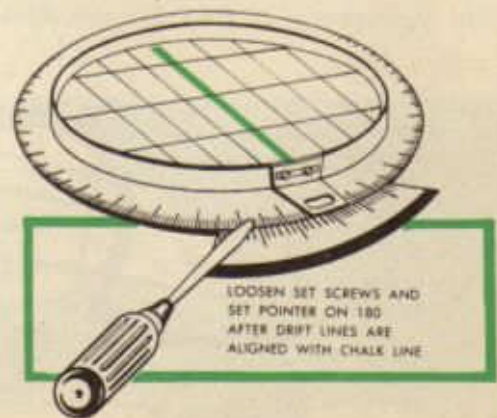

There are three things to do when aligning the B-5 driftmeter, (1) check the driftmeter for internal alignment, (2) lay down a line on the ground in the field of view of the driftmeter perpendicular to the longitudinal axis of the aircraft, and (3) adjust the scale to read zero when the reticle timing lines are parallel to the line on the ground. Working materials needed are the same as for the B-2 and B-3 driftmeters plus a ruler or plotter and a pencil. Do this job as follows:

1. Check the driftmeter for internal alignment: with a pencil in the pencil-holder, trace on the ground glass one of the reticle drift lines. This line should be parallel (within $\frac{1}{2}$ degree) with the lines on the indicator dial. If it is not, open the frame and make two additional checks and adjustments:

Check the alignment of the pantograph needle by laying a ruler or plotter across the centers of the holes for the pencil and the pivot stud. The center of the needle ball should lie on this line, halfway between the pencil hole and the stud hole. If it is out of position, bend it into alignment.

Check for alignment between the reticle drift lines and the lines on the indicator dial by laying a plotter across the reticle and the indicator dial. The lines should be parallel (within $\frac{1}{2}$ degree). If they are not, loosen

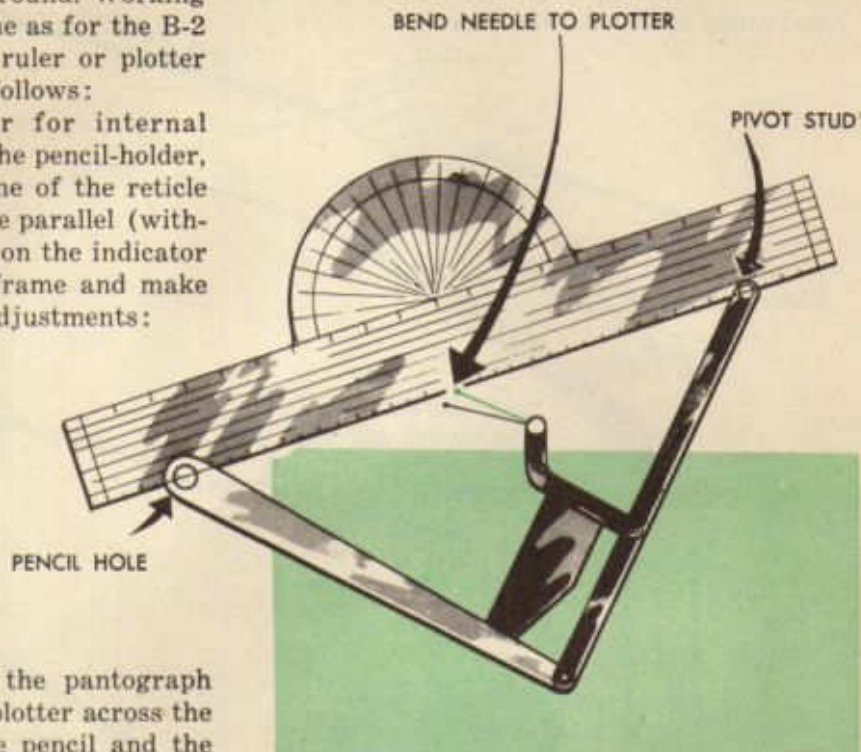

the screws in the triangular plate which attaches the connecting link to the reticle, adjust the reticle until the lines are parallel, and tighten the screws.

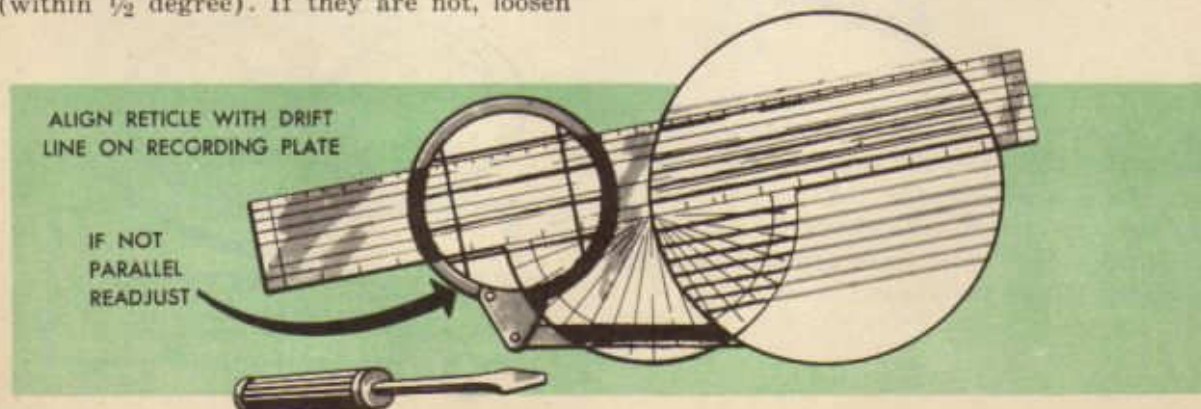

2. Establish the longitudinal axis of the aircraft in the same manner as for the B-2 and B-3.

3. Look through the driftmeter and locate a spot on the ground near the center of one of the reticle timing lines.

4. Through the spot located, construct a line perpendicular to the longitudinal axis line, preferably in the manner illustrated.

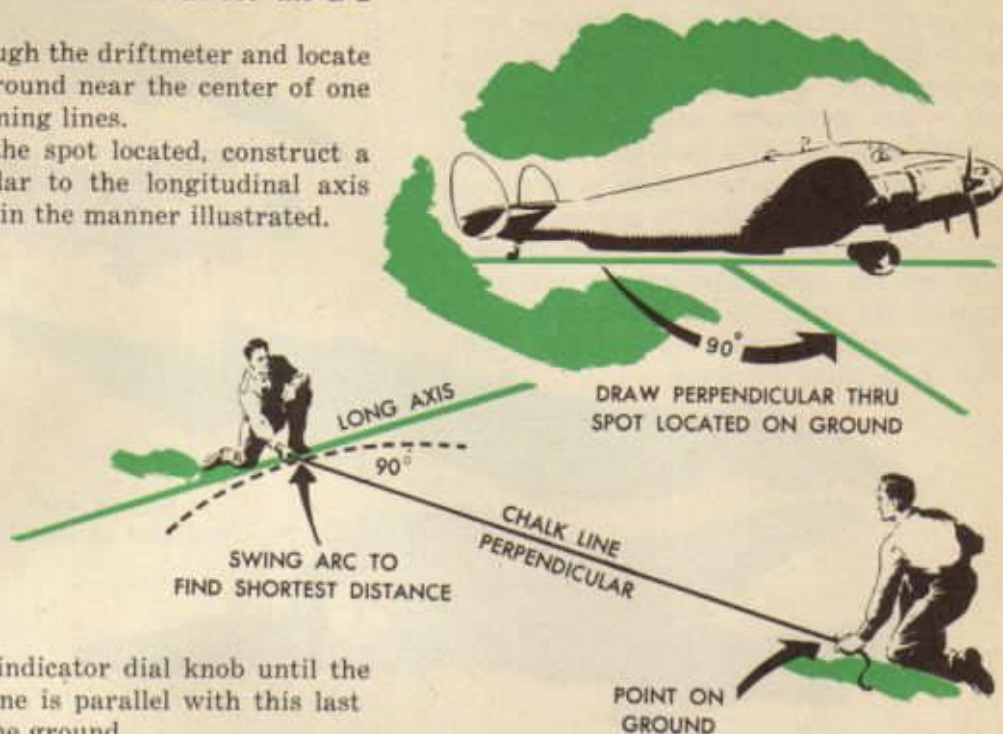

5. Turn the indicator dial knob until the reticle timing line is parallel with this last drawn line on the ground.

6. *Without moving the indicator dial*, loosen the screws holding the drift scale, adjust the scale until the pointer reads zero, and tighten. Check to see that the reticle timing line is still parallel with the line on the ground.

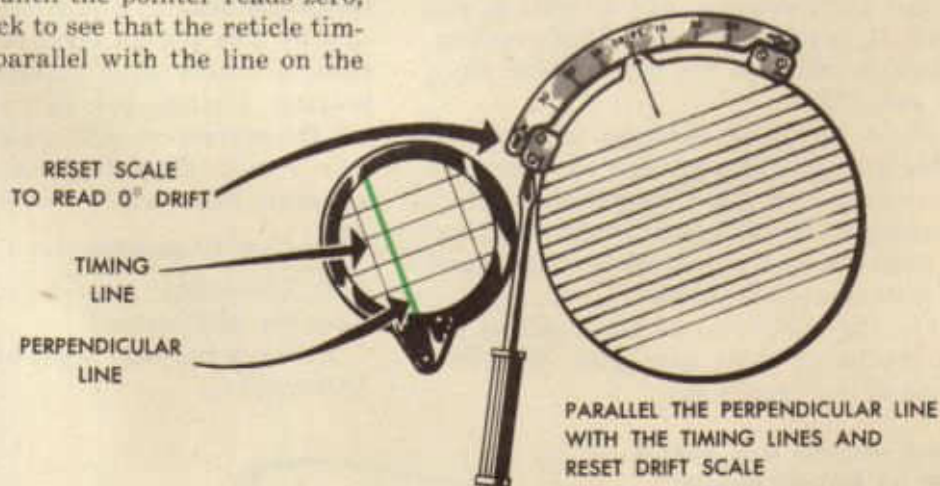

If the navigator uses this method of aligning the B-5, it is not necessary to raise the tail of the aircraft into flight attitude.

Experienced navigators have evolved a plan for making a quick but satisfactory check on the alignment of the B-2 and B-3 driftmeters. With the line-of-sight turned to the greatest possible angle, the navigator locates, on the underpart of the aircraft, a

point that he can see through the driftmeter during flight, usually the pitot-static tube. With the driftmeter correctly aligned, he reads and records the relative bearing indicated by the driftmeter when this point is centered on the middle reticle drift line. Then, before or during all subsequent flights, he can check the alignment by seeing if the relative angle remains the same. If, in the

future, the relative bearing changes, the driftmeter is out of alignment. If he cannot realign the driftmeter at once, he can apply the difference between what the relative bearing should be and what it is as a correction to his driftmeter readings, both drift correction and relative bearings. If the navigator finds that it is impossible to locate any point on the aircraft that he can see through the driftmeter, during flight, he can use some point on the under-carriage or tail-wheel assembly for making a check before take-off, but, of course, he cannot check during flight, when these parts are retracted.

ON GROUND LANDING
GEAR IS USEFUL



DETERMINE CONSTANT BEARING
OF SOME POINT ON SHIP

IN THE AIR PITOT
TUBE MAY BE USED

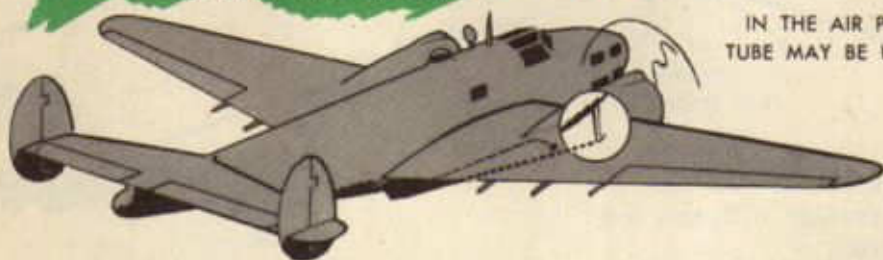

Grim necessity has evolved the following purely emergency check on driftmeter alignment that the navigator will do well to remember. It is rather accurate, but requires considerable effort on the part of both navigator and pilot.

1. Fly a series of headings, staying on each heading just long enough for the navigator to get a good drift correction reading and turning 15 or 20 degrees in the direction of the drift for each new heading, until maximum drift correction is found.

2. Fly the reciprocal of the heading on which maximum drift correction occurred and read drift correction.

3. Add, algebraically, the maximum drift correction and the drift correction on the reciprocal heading and divide their algebraic sum by 2 to get the error of any driftmeter reading, either drift correction or relative bearing. Change the sign of the error to get the correction to be applied. (Example: max d c, +13; d c on reciprocal hdg, -7; algebraic sum, $+13 - 7 = +6$; divide by 2, $\frac{+6}{2} = +3$. Change sign and apply -3 to any drift correction or relative bearing read from the driftmeter.)

To check the trail angle of the B-2 or B-3 driftmeter:

DETERMINE HEADING MAX. DRIFT IS
ON AND FLY RECIPROCAL—ADD 2
DRIFTS ALGEBRAICALLY AND DIVIDE
BY 2 RESULT IS ERROR

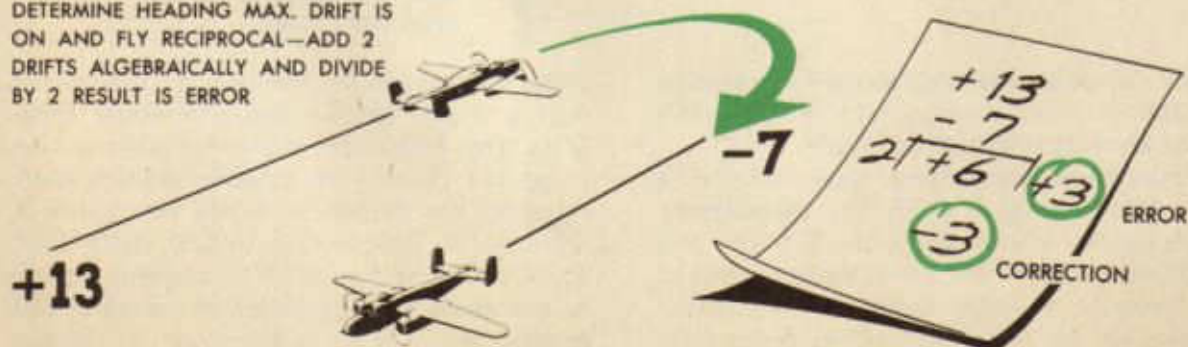

1. Set the line-of-sight control handle at zero and disengage the tangent control knob. The aircraft may be in flight attitude or tail-down.

2. Look through the driftmeter and rotate it through 360 degrees, being careful not to pull loose the electrical connections. Observe the path that the center of the reticle appears to make over the ground. If the aircraft is in flight attitude, this path should be a circle with a diameter not more than 9/10 inch. If the aircraft is tail-down, the path should be an ellipse (oval) not more than 9/10 inch across at the narrow part.

3. If the center of the reticle makes a circle or oval larger than 9/10 of an inch:

Loosen the two set screws in the lock-nut of the line-of-sight control handle sufficiently to free the graduated dial from the handle.

Holding the graduated dial at zero, turn the handle to shift the center of the reticle slightly. Rotate the driftmeter again and observe the path as above. Repeat until, by trial and error, the center of the reticle is made to travel the proper path.

Tighten the loosened screws, taking care not to shift the reticle from its properly adjusted position. Check after screws are tightened by rotating driftmeter again.

If, after several trials, the navigator cannot properly adjust the reticle, he should assume that the fault is in the index prism and should report the fact to the instrument section. The procedure above, called *zeroing*



the trail angle, results in accuracy to within 2 degrees. When greater accuracy is necessary, the job must be done by instrument specialists with special equipment.

For further information on the driftmeter, the navigator should consult the technical orders on the various instruments: B-2: T. O. No. 05-25-2; B-3: T. O. No. 05-25DA-2 or 05-25-3; B-5: T. O. No. 05-35-20.

AIRSPPEED METER

Previous discussion has pointed out that, to get TAS, the navigator (1) reads IAS from the dial face of the airspeed meter, (2) consults the *airspeed calibration card* (W. D., A. C. Form No. 21 E), hanging nearby, to convert IAS into CAS, and (3) figures, on his computer, and applies to the CAS a correction for variation in density to get TAS. The various procedures which result in the airspeed calibration card are called *calibration of the airspeed meter*. These procedures are described at length in Technical Order No. 05-20-8, which should be studied carefully at the first opportunity and consulted when any question arises about this technique.

The corrections found by the calibration of the airspeed meter offset only the errors in the airspeed reading caused by (1) minor mechanical faults in the airspeed meter head (indicator), (2) peculiarities of the pitot tube, (3) changes in the flying attitude of the aircraft at different airspeeds, and (4) variations in pressure around the aircraft at various airspeeds. It is not practicable to compute these corrections; they are determined experimentally for each airspeed

CALIBRATION FINDS ERROR IN

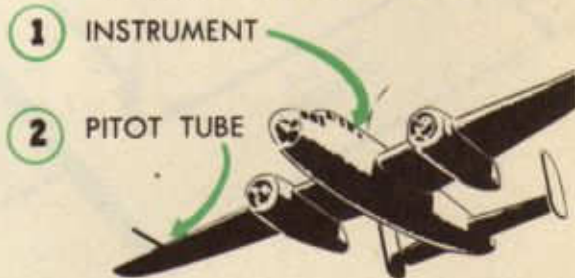

meter installation in the aircraft by timing the passage over a measured course. Remember—these errors are of such a size that the navigator cannot obtain even a reasonably accurate TAS by correcting the IAS for density. He must first correct for these mechanical and installation errors.

No definite period for recalibrating airspeed meter installations can be laid down. They must be calibrated, however, when the pitot-static tube is damaged or disturbed in any manner or when the indicator is moved or disturbed.

To perform an airspeed calibration, the navigator will need (1) a stop-watch reading in tenths of seconds, (2) a free-air temperature gauge, (3) access to a calibrated type H-1 or H-2 station altimeter, usually found at Operations or the Weather Office, (4) work sheets, such as illustrated herein, (5) charts from which to take the *correction factor*, found on pages 6-8, T. O. No. 05-20-8, and (6) airspeed calibration cards, W. D., A. C. Form No. 21 E.

The following paragraphs present in condensed form the procedure to be followed in

calibrating airspeed meter installations. For further explanation of the various steps, the navigator should consult the technical order rather than some less authoritative source.

1. Prepare an accurately measured speed course over level ground or over water. The total length must be at least seven statute miles. The center five-mile section (speed course) must be clearly marked off by sighting markers at least 400 yards apart. Two parallel roads or railroads five miles or more apart are excellent speed course markers, provided there is at least one mile clear be-

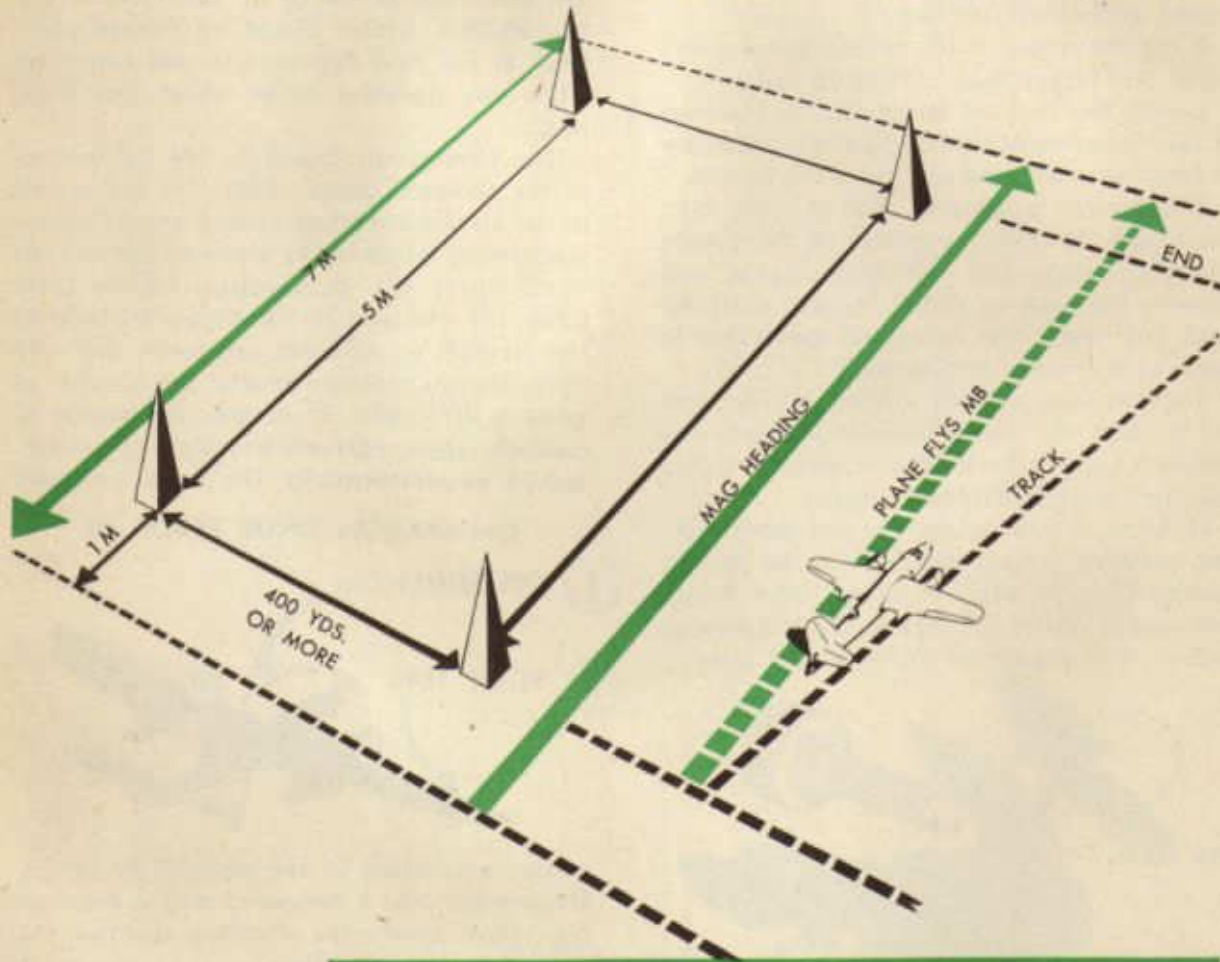

START AND STOP
TIME WHEN
MARKERS ARE
ALIGNED

yond the road at either end of the course.

2. Assign, in addition to the pilot, an observer for each airspeed indicator in the aircraft. All the airspeed indicators in the aircraft must be calibrated at the same time.

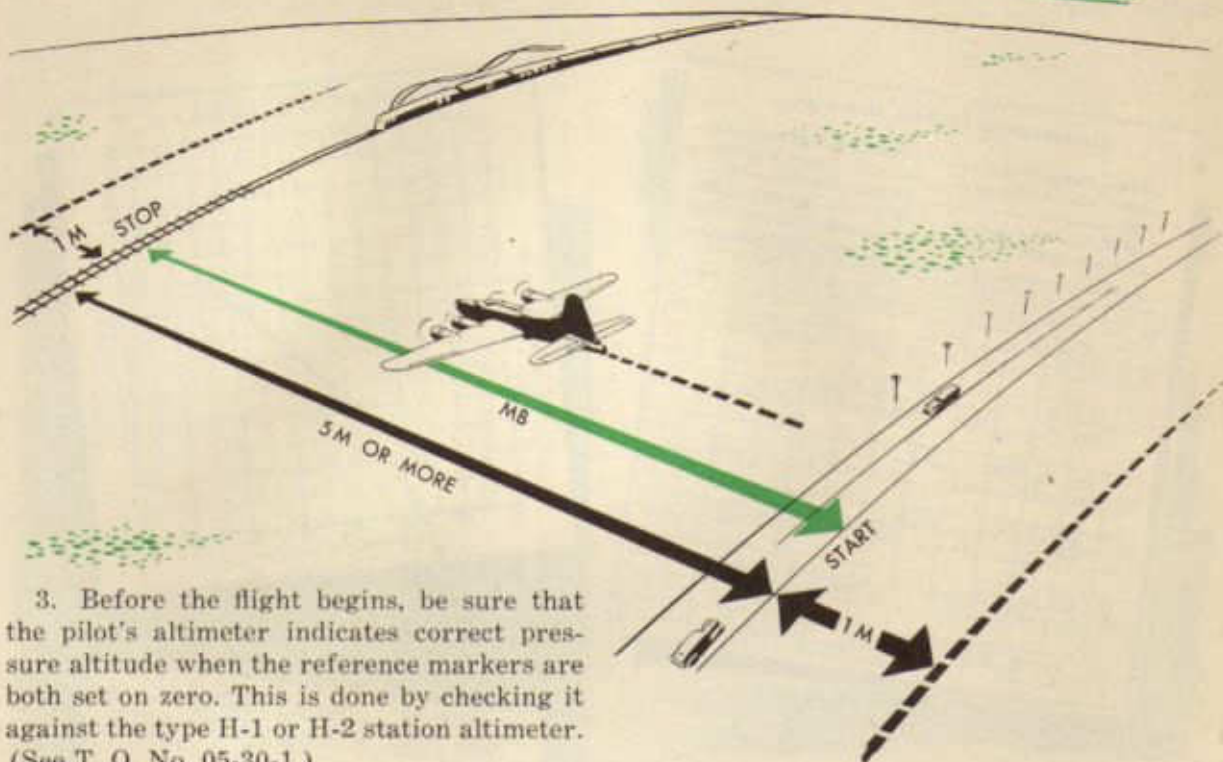

3. Before the flight begins, be sure that the pilot's altimeter indicates correct pressure altitude when the reference markers are both set on zero. This is done by checking it against the type H-1 or H-2 station altimeter. (See T. O. No. 05-30-1.)

4. To insure a constant altitude on all runs over the course, it is common practice to fly all runs about 500 feet above the ground. The pilot must record the reading of his altimeter on each run.

5. If sighting markers are used, all runs will be made to one side of them so that the markers may be lined up by the observers to indicate the beginning and the end of the measured speed course.

6. Runs are made in pairs, one down and one back, at the same airspeed. During the run down, the pilot holds a compass course equal to the magnetic bearing of the speed course as laid out on the ground, and during the run back, flies a reciprocal (opposite) course.

7. The pilot makes the first pair of runs at the maximum allowable speed, using the mile approach area to make sure that no speed is carried over from the glide made to get close to the ground.

8. The pilot then makes other pairs of runs, each at an airspeed of between 15 and 20 mph less than the preceding pair. Entry onto the course should be made each time without excessive diving; no change in altitude or airspeed should be made during the mile approach prior to entry onto the measured speed course. A uniform airspeed over the entire length of the speed course is absolutely necessary if reasonable accuracy is to be obtained. No special effort should be made to fly airspeeds divisible by five.

9. On each run, each observer measures as accurately as possible the time interval between entering and leaving the measured speed course, and observes the IAS and the free air temperature. He gets the pressure altitude for each run from the pilot at the conclusion of the flight.

COMPASS COMPENSATION

Previous discussions have emphasized the fact that small magnetic fields within the aircraft distort the earth's magnetic lines of force about the aircraft compass and cause it to deviate from magnetic north. While care in aircraft manufacture may hold such distortion to a minimum, it cannot eliminate it entirely. The navigator always must assume that compass north differs from magnetic north and, hence, that compass headings always differ from magnetic headings.

The navigator knows, by this time, that he can find the deviation of his compass on any heading by subtracting the compass heading from the actual magnetic heading. Any time, therefore, that he can obtain the actual magnetic heading, he can determine the deviation.

At times, during a flight, though, it may be inconvenient or impossible for him to determine the actual magnetic heading and, there-

fore, to determine the deviation. At such times the navigator must depend on his deviation card. Thus, a correct deviation card is very important. The navigator knows, too, that the deviation of his compass is likely to change at any time and he must, therefore, check his deviation card often.

To do this, the navigator must (1) find the actual deviation on four headings 90 degrees apart, preferably the cardinal headings, and (2) compare the deviations found with those recorded on the deviation card for those respective headings. If they differ, he must compensate the compass and make up a new deviation card.

To compensate a compass, the navigator changes the magnetic fields around it. This he does by placing small magnets in the *compensating trays* of the navigator's D-type compass or by turning the screws that change the position of small magnets already in the pilot's B-type. These magnets counteract the influence of the magnetic fields around the compass and reduce the *amount* of the deviations so that they are more convenient to use.

To compensate a compass and to make up a new card, the navigator must do six things, (1) remove previous compensation, (2) find the deviation on the four cardinal headings

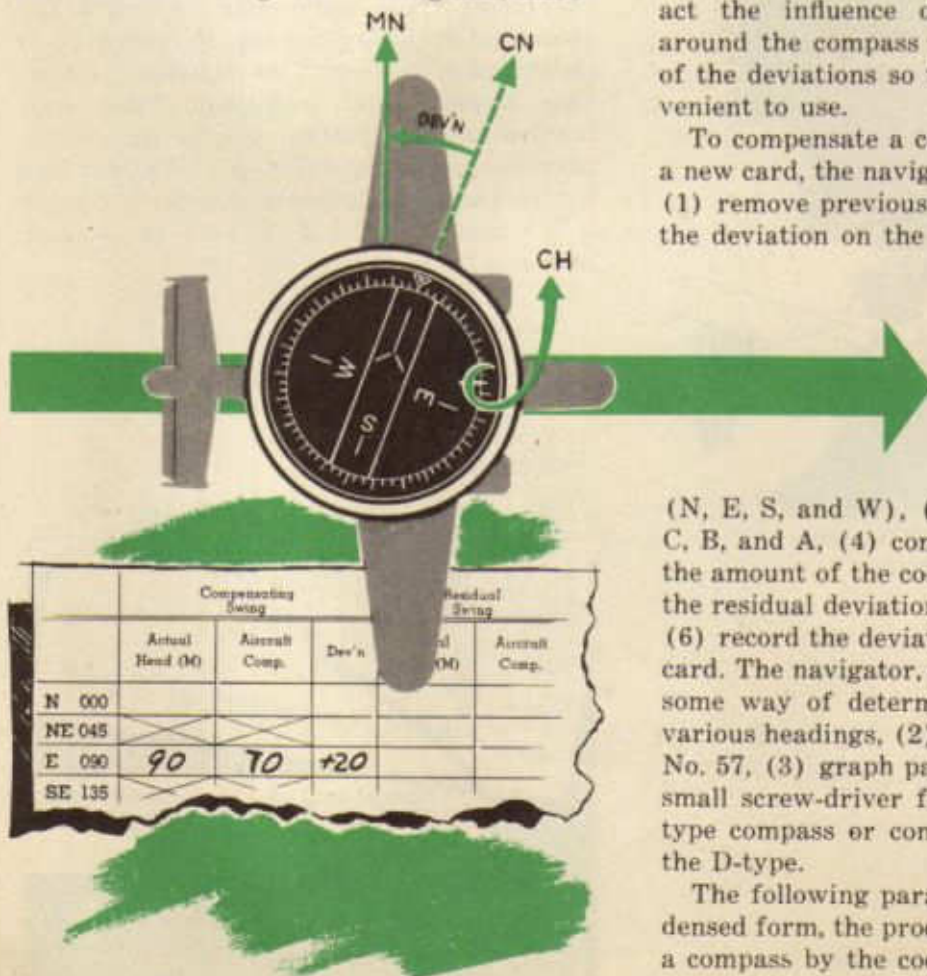

(N, E, S, and W), (3) compute Coefficients C, B, and A, (4) compensate the compass to the amount of the coefficients found, (5) find the residual deviation on eight headings, and (6) record the deviations on a new deviation card. The navigator, to do this, will need (1) some way of determining deviation on the various headings, (2) a supply of AAF Form No. 57, (3) graph paper and pencil, and (4) small screw-driver for compensating the B-type compass or compensating magnets for the D-type.

The following paragraphs present, in condensed form, the procedure for compensating a compass by the coefficient method and for

preparing a new deviation card. For additional information on any step, the navigator should consult Technical Order No. 05-15-2 and No. 05-15-3.

1. Remove previous compensation from D-type compass by removing small magnets from the compensating trays and replacing trays, or from B-type compass by turning the N-S and E-W screws for minimum effect.

2. Find the magnetic and compass headings of N, S, E, and W by swinging the compass (called the *compensating swing*). Assume for the present that the compass has been swung and that the following headings have been obtained:

- N: 360 M—354 C
- E: 090 M—076 C
- S: 180 M—178 C
- W: 270 M—276 C

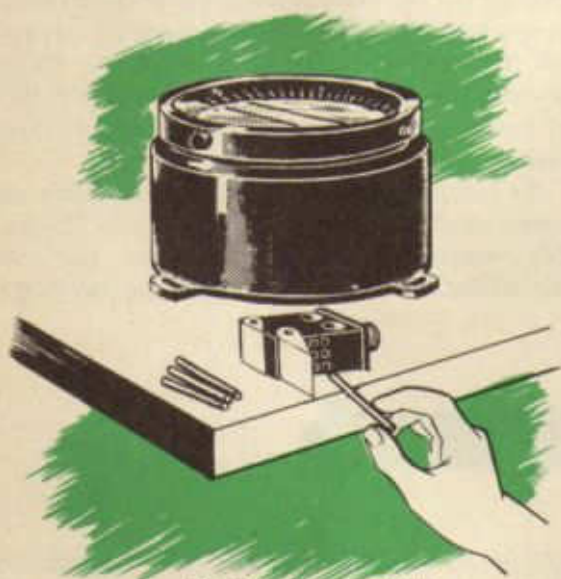

REMOVE ALL PREVIOUS COMPENSATION

Enter this information properly on AAF Form No. 57.

3. Subtract the compass heading from the magnetic heading to get deviation on each heading:

- N: 360 — 354 = +6
- E: 090 — 076 = +14
- S: 180 — 178 = +2
- W: 270 — 276 = -6

Enter these properly on the form.

	Compensating Swing		
	Actual Head (M)	Aircraft Comp.	Dev'n
N 000	360	354	+6
NE 045			
E 090	90	76	+14
SE 135			
S 180	180	178	+2
SW 225			
W 270	270	276	-6
NW 315			
	(1)	(2)	(1)-(2)

4. Compute Coefficients C, B, and A, using the guide provided at the bottom of the form. These coefficients represent the amount of deviation it is safe to remove from the compass. To remove more makes the compass sluggish and inefficient. Place both the amount of deviation and its sign in the parentheses on the form. All additions and subtractions are algebraic, that is, + (+) or - (-) means *add* and + (-) or - (+) means *subtract*:

Coeff. C =

$$\frac{N - S}{2} = \frac{(+6) - (+2)}{2} = \frac{+4}{2} = +2$$

Coeff. B =

$$\frac{E - W}{2} = \frac{(+14) - (-6)}{2} = \frac{+20}{2} = +10$$

If swinging compass used ahead of aircraft add or subtract

Coeff. C = $\frac{N - S}{2} = \frac{(+6) - (+2)}{2} = +2$

Coeff. B = $\frac{E - W}{2} = \frac{(+14) - (-6)}{2} = +10$

Coeff. A = $\frac{N + E - S - W}{4} = \frac{(+6) + (+14) - (+2) - (-6)}{4} = +4$

Compass Reading + Coeff = Compensated Comp. Read.
 $354^\circ + (+2) = 356^\circ$

① AMOUNT OF DEV TO REMOVE IS DETERMINED BY FORMULA

② RESULT IS ALGEBRAICALLY ADDED TO COMPASS READING

$$\text{Coeff. A} = \frac{N + E + S + W}{4} =$$

$$\frac{(+6) + (+14) + (+2) + (-6)}{4} =$$

$$\frac{+16}{4} = +4$$

5. Add Coeff. C (+2) to the compass reading on the N heading (354) to find what the compass must read when Coeff. C is compensated for (356).

COMPENSATING THE APERIODIC COMPASS



MAGNET ORIENTED BY PLACING ON TOP OF CASE AND WATCHING DIRECTION COMPASS NEEDLE MOVES



INSERT MAGNET AT RIGHT ANGLE TO COMPASS NEEDLE. NUMBER OF NEEDLES QUICKLY DISCOVERED BY TRIAL AND ERROR



Turn the aircraft on the N heading (compass reading 354) and compensate the compass until it indicates the desired reading (356) by turning the N-S screw of the B-type or by placing magnets in the N-S tray of the D-type. Determine which end of the magnet to put in the tray first by laying the magnet on the top of the compass, parallel with the N-S tray, and seeing that it moves the compass card in the correct direction.

6. Add Coeff. B to the compass reading of the E heading: $076 + (+10) = 086$. Turn the aircraft until the compass reads 076 and compensate the compass until it reads 086 by turning the E-W screw of the B-type or by placing magnets in the E-W tray of the D-type.



7. Add Coeff. A to the compass reading of the S (or any other) heading: $178 + (+4) = 182$. Turn the aircraft until the compass reads 178 and, for the D-type compass, loosen the mounting screws, adjust the entire compass until it reads 182, and tighten the mounting screws. Do not try to compensate the B-type compass for Coeff. A.

Removal Setting	Aircraft Comp.		Date	
	Actual Head (M)	Aircraft Comp.	C to M	M to C
	358	357		000
	43	41		045
	89	86		090
	137	138		135
	181	182		180
	223	225		225
	271	274		270
	315	317		315

8. Find the magnetic and compass headings on N, NE, E, SE, S, SW, W, and NW by swinging the compass again (called the *residual swing*). Assume that the following values were obtained:

- N: 358 M—357 C,
- NE: 043 M—041 C,
- E: 089 M—086 C,
- SE: 137 M—138 C,
- S: 181 M—182 C,
- SW: 223 M—225 C,
- W: 271 M—274 C,
- NW: 315 M—317 C.

Record these values in the proper spaces on Form No. 57.

9. Subtract the compass headings from the respective magnetic headings and record the result (deviation) in the proper space in the *C to M* column of the form.

10. Subtract the magnetic headings from the respective compass headings and record the result (deviation correction) in the proper space in the *M to C* column of the

	Compensating Swing			Residual Swing		Aircraft Comp.		Date	
	Actual Head (M)	Aircraft Comp.	Dev'n	Actual Head (M)	Aircraft Comp.	C to M		M to C	
N 000						+1	000	-1	
NE 045						+3	045	-3	
E 090						+4	090	-4	
SE 135						+1	135	-1	
S 180							180		
SW 225									

form. Note that the *C to M* and the *M to C* columns are identical except that the signs are reversed.

11. Fill out the front of the card; date and cut off the last three columns of the back. Place the cut-off portion of the card in the aircraft, in the holder provided; file the remaining portion as provided locally.

	Compensating Swing			Residual Swing		Aircraft Comp.		Date	
	Actual Head (M)	Aircraft Comp.	Dev'n	Actual Head (M)	Aircraft Comp.	C to M		M to C	
N 000	360	354	+6	358	357	+1	000	-1	
NE 045				43	41	+2	045	-2	
E 090	90	76	+14	89	86	+3	090	-3	
SE 135				137	138	-1	135	+1	
S 180	180	178	+2	181	182	-1	180	+1	
SW 225				223	225	-2	225	+2	
W 270	270	276	-6	271	274	-3	270	+3	
NW 315				315	317	-2	315	+2	
	(1)	(2)	(1)-(2)	(3)	(4)	(3)-(4)		(4)-(3)	

COMPASS CARD

If swinging compass used ahead of aircraft add or subtract 180 degrees.

$$\text{Coef. C} = \frac{N-S}{2} = \frac{(+6) - (+2)}{2} = +2$$

$$\text{Coef. B} = \frac{E-W}{2} = \frac{(+14) - (-6)}{2} = +10$$

$$\text{Coef. A} = \frac{N+E+B+W}{4} = \frac{(+6) + (+14) + (+2) + (-6)}{4} = +4$$

AAF FORM NO. 57

The navigator often performs the residual swing (step No. 8) in the air, where it may be inconvenient or impossible to fly on exact magnetic headings (N, NE, E, etc.). If he flies close to the exact headings (plus or minus 5 degrees), no appreciable error will result, provided he uses the exact headings flown in his computations. If he does not fly within 5 degrees of the exact headings, he should compute the deviations on the headings flown as in step No. 9. Before recording deviations in the *C to M* column, however, he should prepare a graph by plotting deviations against the magnetic headings flown, and pick off the graph the deviations for the exact magnetic headings shown on the form. If, on a residual swing, the navigator finds

the following deviations on the headings indicated: 010 M, +2; 045 M, +4; 096 M, +5; 130 M, +4; 180 M, 0; 230 M, -4½; 270 M, -5; 295 M, -4½; 350 M, -2; he should prepare a graph, as illustrated. From it he can pick off deviation at the exact headings (360, 045, 090, etc.), record it in the *C to M* column of the form, reverse the signs, and fill in the *M to C* column.

If the navigator finds, on the compensating swing, a B-type compass deviating more than 25 degrees on any heading or a D-type, more than 15 degrees, or, if he finds, on a residual swing, a B-type deviating more than 10 degrees or a D-type, more than 5 degrees, he should report such fact to the Instrument Section.

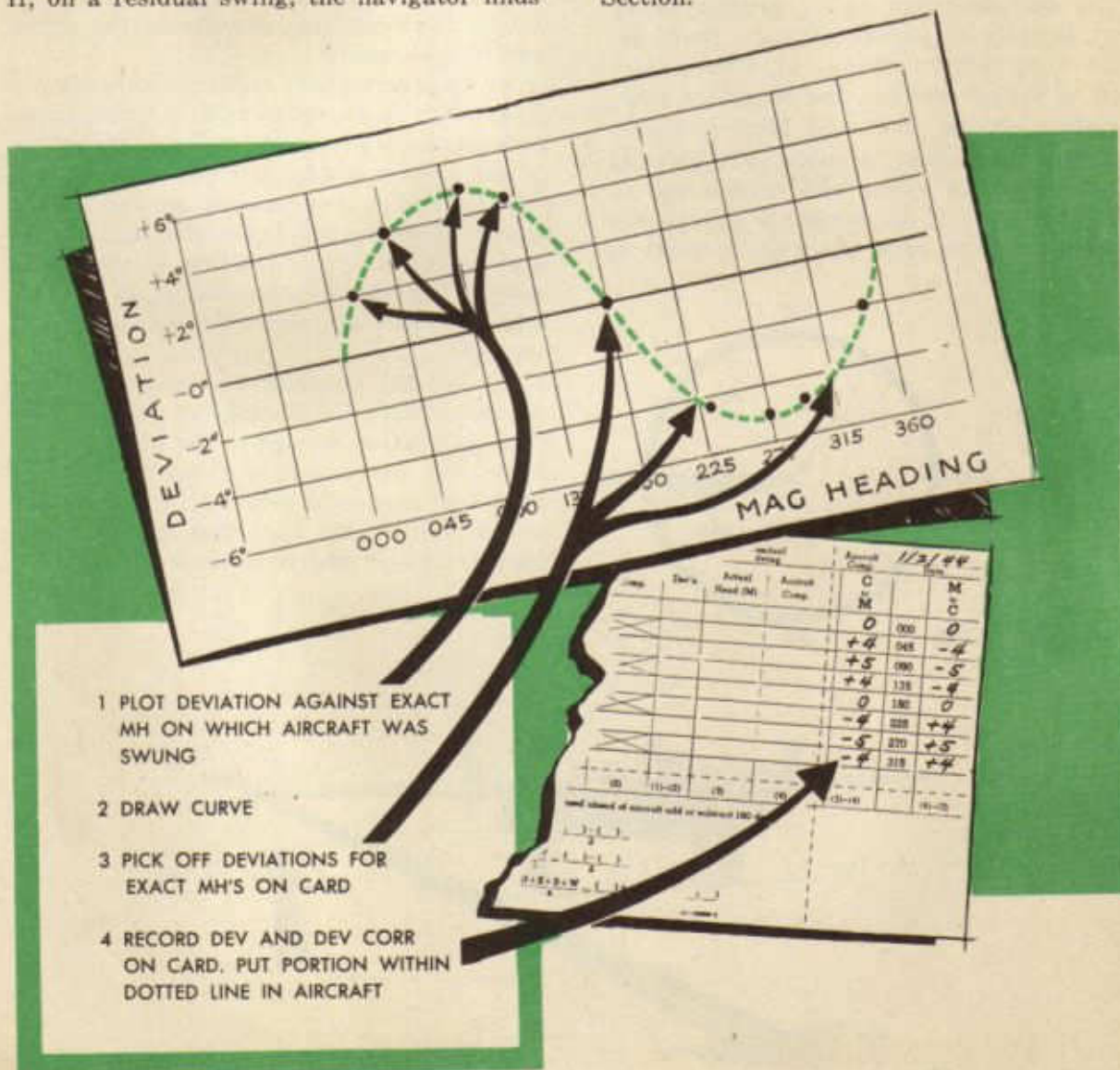

SWINGING THE COMPASS

Before a navigator can compensate a compass and make up a new deviation card for it, he must find the deviation on selected headings. To find the required deviations, he must know both the compass headings and the magnetic headings. To get the compass headings he merely reads the compass. To get the magnetic headings, he must use one of the several devices available for determining the magnetic headings of the aircraft on the ground or in flight. The procedure whereby the navigator finds the required compass and magnetic headings he calls *swinging the compass*, either *ground swinging* or *air swinging*.

The navigator can safely ground swing most aircraft in parked attitude. Some he must swing in flight attitude. If, with the aircraft in parked attitude, the navigator finds deviation on the East and West headings approximately equal in value, but opposite in sign, he can swing and compensate in parked attitude. If the values are not approximately equal, he must place the aircraft in

flight attitude by placing the tail-wheel on a movable carriage. If he finds no difference in deviation with engines running and engines off, he can swing and compensate with engines off. The same holds for radios and other electrical equipment. Until he is sure, however, the navigator should swing and compensate with the aircraft in flight attitude, the engines running, and the radio and all electrical equipment turned on.

If he decides to swing in flight attitude, he must secure a lift (usually a jack) and a specially made, non-magnetic carriage, lift the tail, lash the tail-wheel securely to the carriage, and adjust the carriage until the aircraft is in flight attitude. He must move the lift at least 100 feet from the aircraft so as not to affect the compass during the swing and compensation.

At most permanent stations the navigator finds available a large circular concreted area called a *compass swinging base*. In the center of the area is a wood bar that is used as a wheel chock. It is pivoted at one end so that it may be swung and fastened in any of several positions. Each position is labeled to indicate the magnetic heading of an aircraft whose wheels are correctly placed against the bar.

To use the compass swinging base, the navigator fixes the bar at the desired position and taxis or pushes the aircraft into place, the wheels just touching the bar. He reads the magnetic heading from the label at the end of the bar. This procedure he repeats on each desired heading.

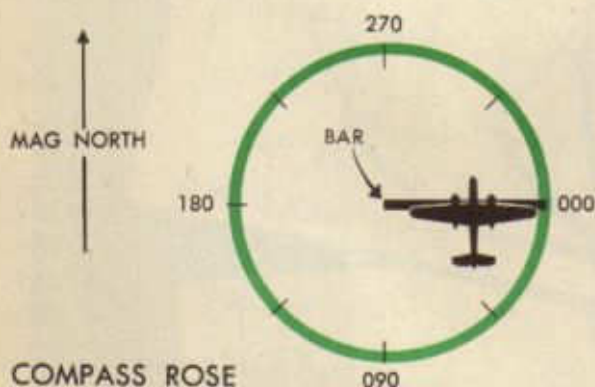

COMPASS ROSE

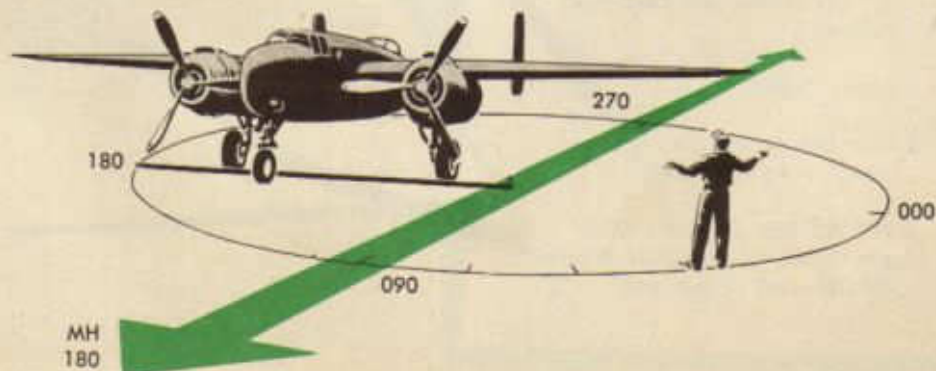

If no compass swinging base is available, the navigator may find the magnetic headings required for swinging and compensation by means of a *swinging compass*. This instrument is a B-type compass with the compensator assembly removed and a special sight attached in its place.

To use the swinging compass, the navigator looks through the transparent plate and lines up the vertical hair-line with the object whose magnetic bearing he is measuring. Holding the hair-line on the object, he looks through and over the lens and adjusts the compass until the portion of the hair-line seen through the lens lines up with the portion seen above the lens. The compass reading then indicates the magnetic bearing of the *branch* (line) between the compass and the object sighted.

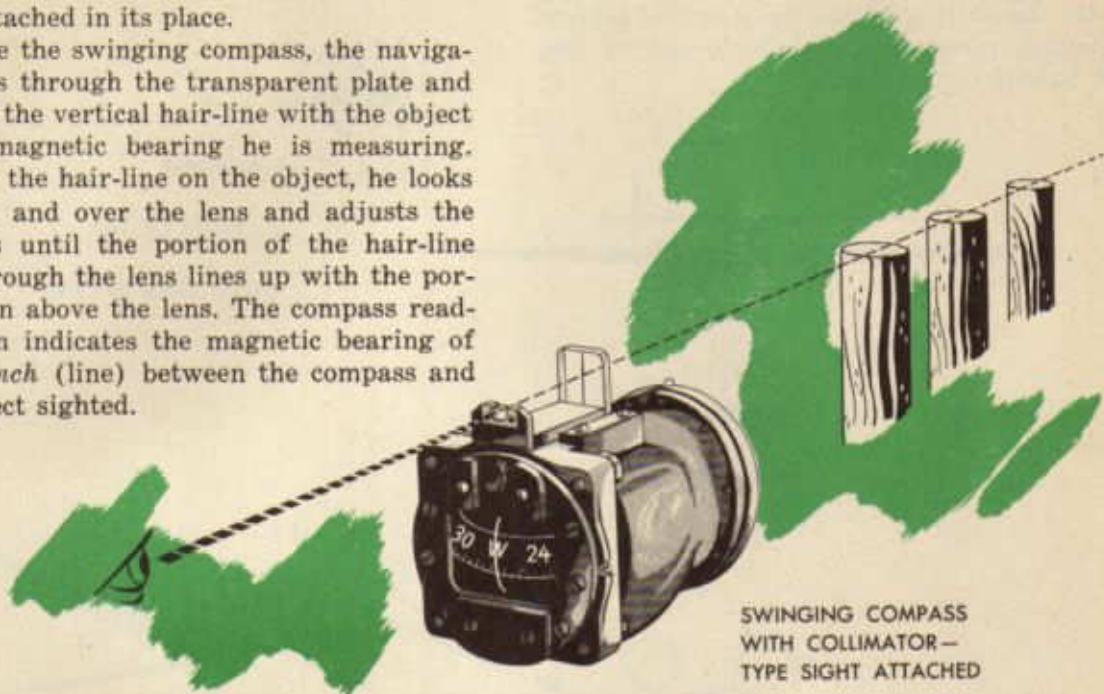

SWINGING COMPASS
WITH COLLIMATOR—
TYPE SIGHT ATTACHED

Before he uses the swinging compass, the navigator must check the alignment of the sight. To do this:

1. Find the bearing of a distant object, preferably a mile or more away, in the manner just directed.

2. Place a wood ruler or some other flat, non-magnetic straight-edge against the face of the compass, sight down the ruler and align it with the same distant object, and have an assistant read the compass. This

reading, plus 90 degrees if the compass faces the navigator's right or minus, if the left, is the correct magnetic bearing of the object.

3. If the first reading does not agree with the correct magnetic bearing, subtract the first reading *from* the correct magnetic bearing and use the remainder, *with its sign*, as the correction for all readings of the swinging compass.

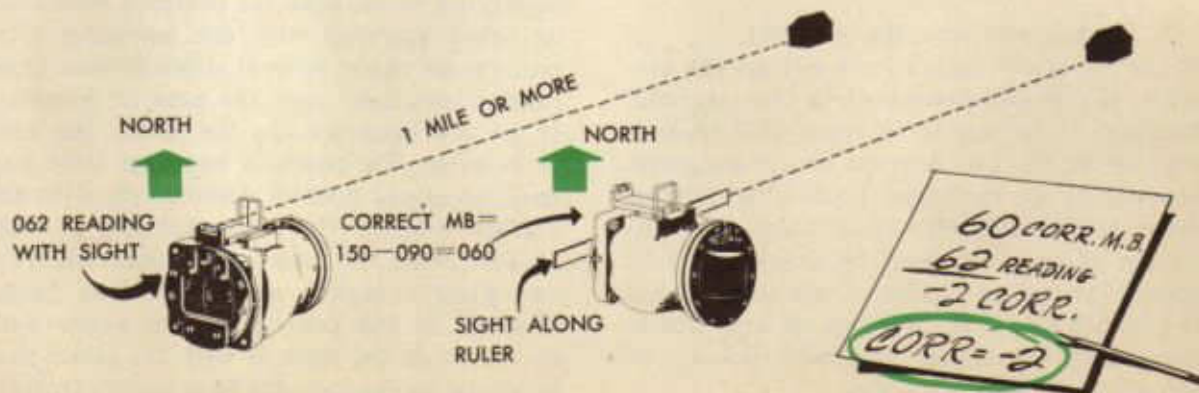

To determine the magnetic heading of an aircraft with the swinging compass:

1. Stand at least 50 feet from the aircraft, ahead or behind.
2. Align the swinging compass with the longitudinal axis of the aircraft by aligning with the radio mast and fin, a row of central fuselage rivets, or any suitable pair or line of objects on the aircraft.

Align...

- 1 ANTENNA
- 2 CENTER OF TAIL
- 3 HAIR LINES IN LENS

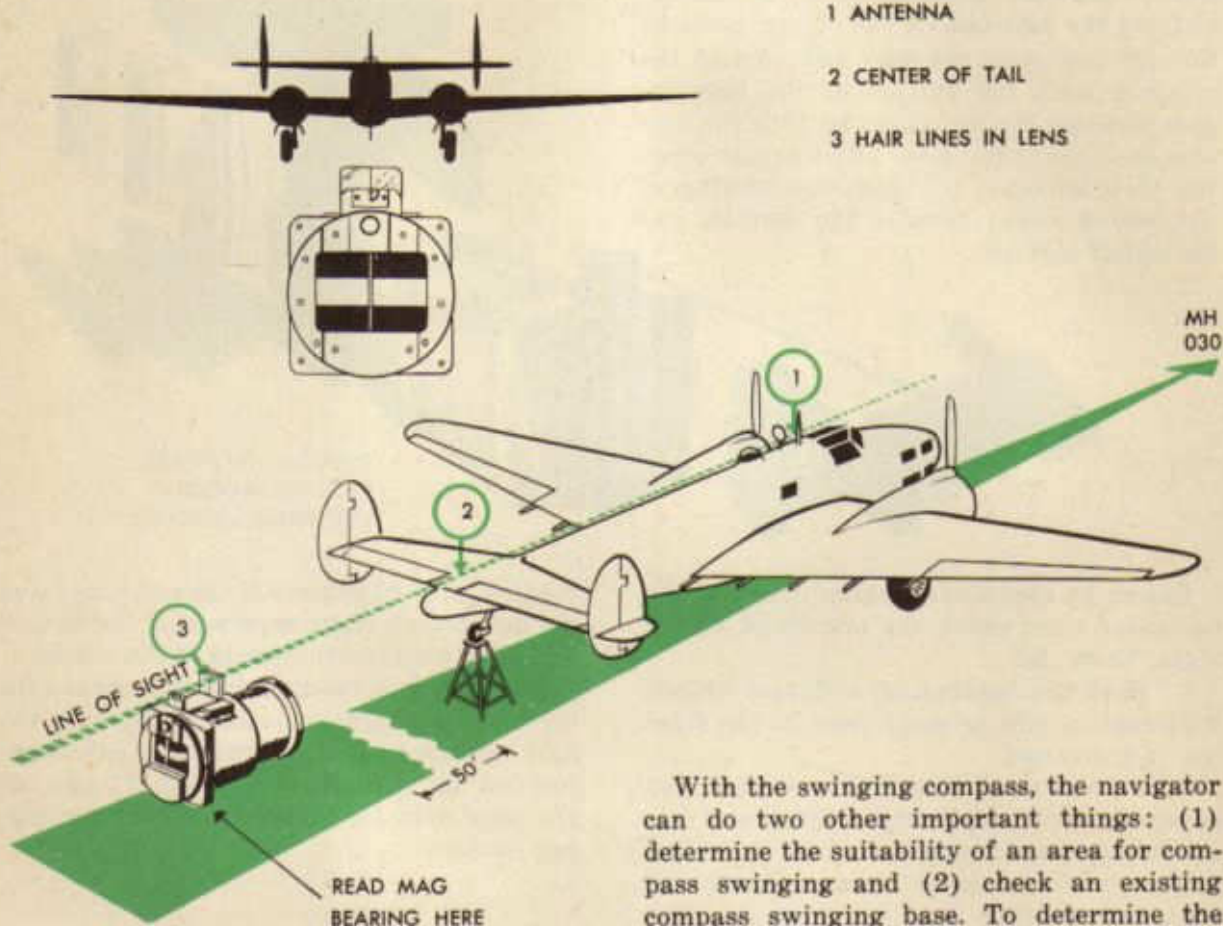

3. Steady and read the compass.

If the navigator sights from behind the aircraft, the reading obtained is the magnetic heading. If he stands in front, the reading plus or minus 180 degrees is the magnetic heading. If the navigator prefers to stand in front of the aircraft, away from the slipstream of the propellers, he should obtain a special swinging compass, always painted red, which reads 180 degrees off and which, thus, reads the correct magnetic bearing of the aircraft from the front.

With the swinging compass, the navigator can do two other important things: (1) determine the suitability of an area for compass swinging and (2) check an existing compass swinging base. To determine the suitability of an area for compass swinging, he takes bearings with the swinging compass on an object several miles distant from random positions over the area in question. If all the bearings are the same, the area is suitable. To check a compass swinging base, he aligns himself successively with the marked lines on the base, standing at least 50 feet from the base, and sights with the swinging compass along the line being checked. If the bearings taken agree with the labels on the lines or with the labels plus or minus 90 degrees, the base is satisfactory.

The navigator may use any of several methods to find the magnetic heading of an aircraft in flight. Some of these methods use celestial observations; others use a straight road, railroad, etc., whose magnetic bearing is known. If the navigator can find the angle from such a road to the longitudinal axis of an aircraft, he can find the magnetic heading of the aircraft by adding the angle to the magnetic bearing of the road.

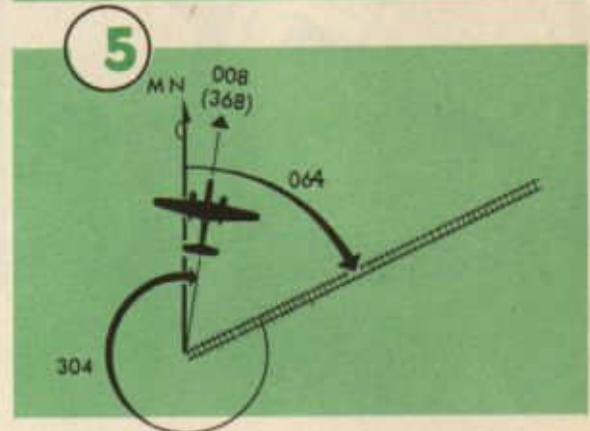
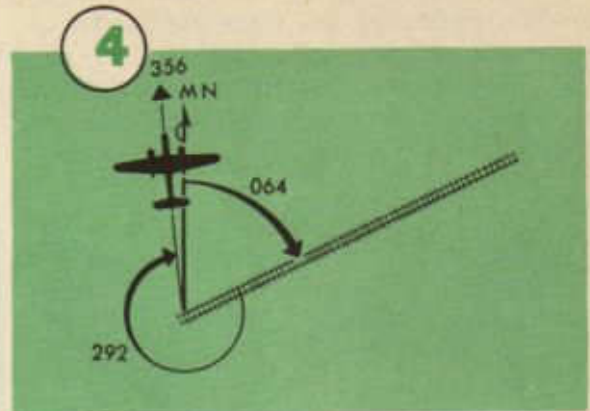
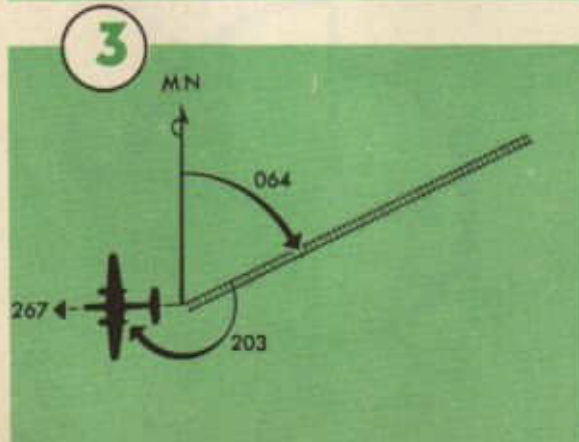
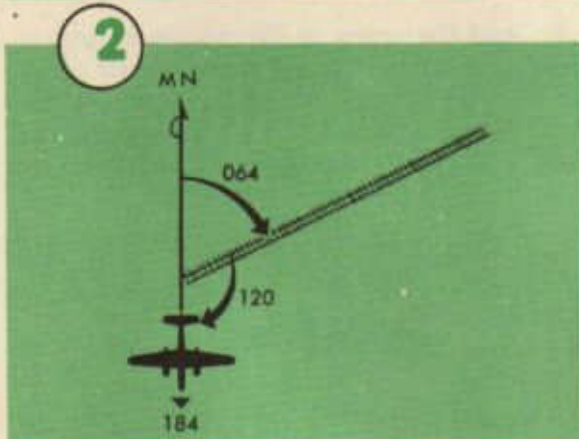
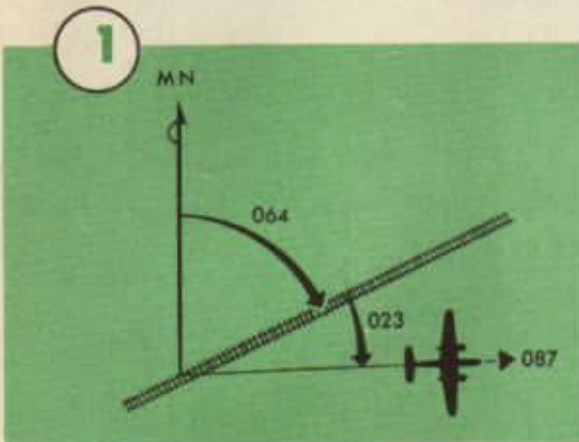

The navigator can find this angle with the B-3 driftmeter. He finds it and uses it to find the magnetic heading of the aircraft in the following steps:

1. Select the road to be used and measure its magnetic bearing, preferably with the swinging compass. In an emergency, the bearing may be measured on a chart. Remember that a road has *two* magnetic bearings, one up the road and one down it.

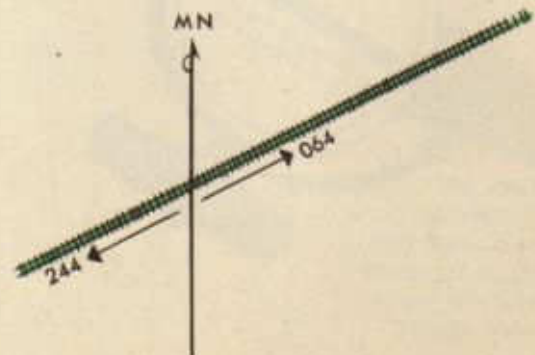

2. When approaching the road in flight, turn the driftmeter and place the pointer at zero on the azimuth scale.

3. Turn the line-of-sight forward, locate the road, and align the reticle timing line with the road.

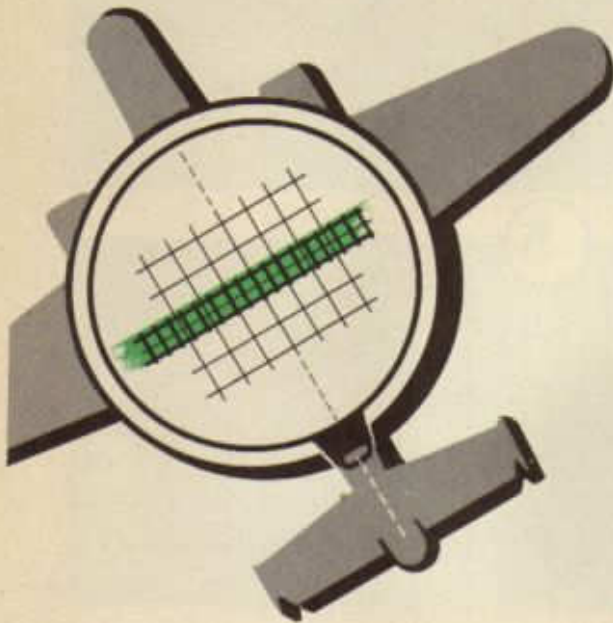

4. Turn the driftmeter 90 degrees clockwise, engage the A-2 clutch, turn the line-of-sight to zero, and wait for the road to come into the field of vision.

5. Using the A-2 clutch, quickly and carefully adjust the alignment of the reticle drift lines with the road.

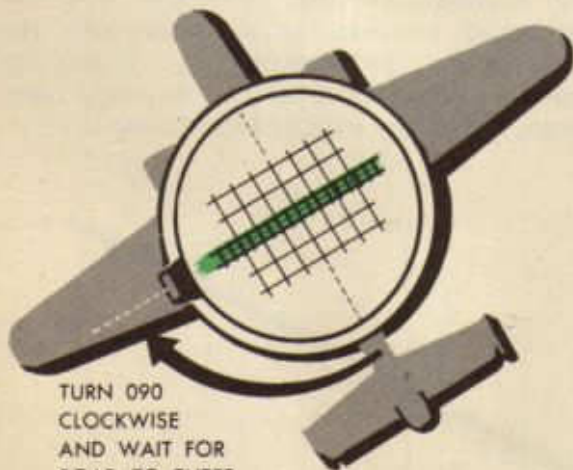

TURN 090
CLOCKWISE
AND WAIT FOR
ROAD TO ENTER
FIELD OF VISION
THEN ADJUST

6. Read the compass and the driftmeter pointer, and record the readings.

7. Subtract the pointer reading from 360 to get the angle from the road to the longitudinal axis of the aircraft.

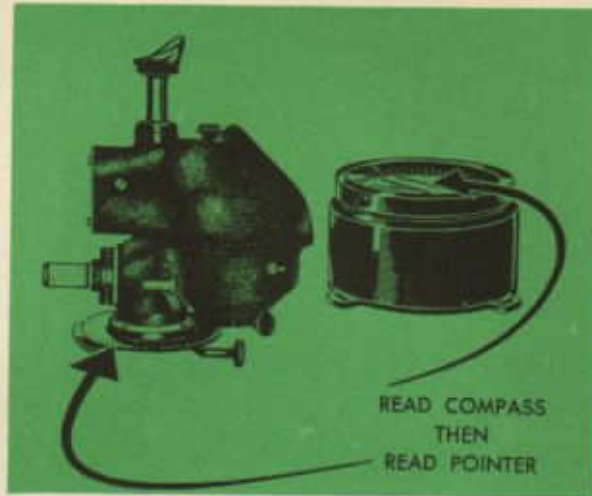

8. Add the angle to the proper magnetic bearing of the road to get the magnetic heading of the aircraft. Compare the compass heading read in step No. 6 with this magnetic heading to get deviation on the heading.

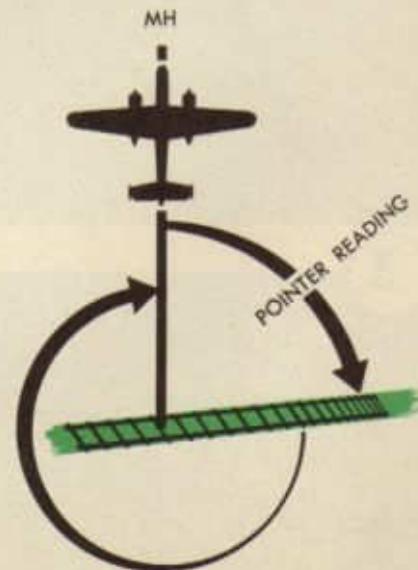

ANGLE FROM ROAD TO LONG.
AXIS OF AIRCRAFT

Groundspeed By Timing

The navigator should know his groundspeed as accurately as possible at all times. He can determine it by timing his passage over two points a known distance apart, but, to be accurate, this must take several minutes at best. If he knows the wind, he can find the groundspeed by graphic or computer solution of the wind triangle. But he may not know the wind and it may be inconvenient, as in formation flying, to fly different headings in order to find it. Under such conditions, he can find the groundspeed in about a minute by using the driftmeter and following a procedure called *groundspeed by timing*. Before he can use this procedure, he must know his absolute altitude as accurately as possible. The groundspeed he finds by timing will be accurate only in the proportion that the absolute altitude is accurate.

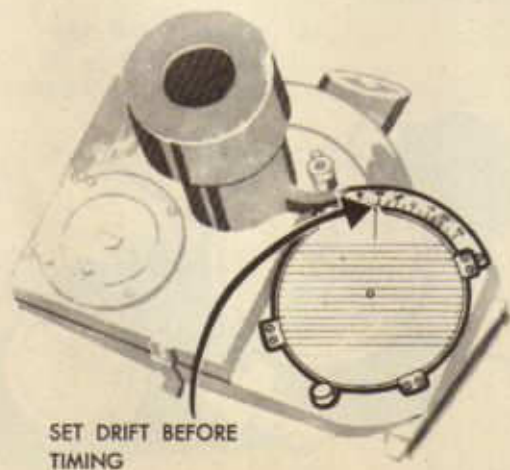
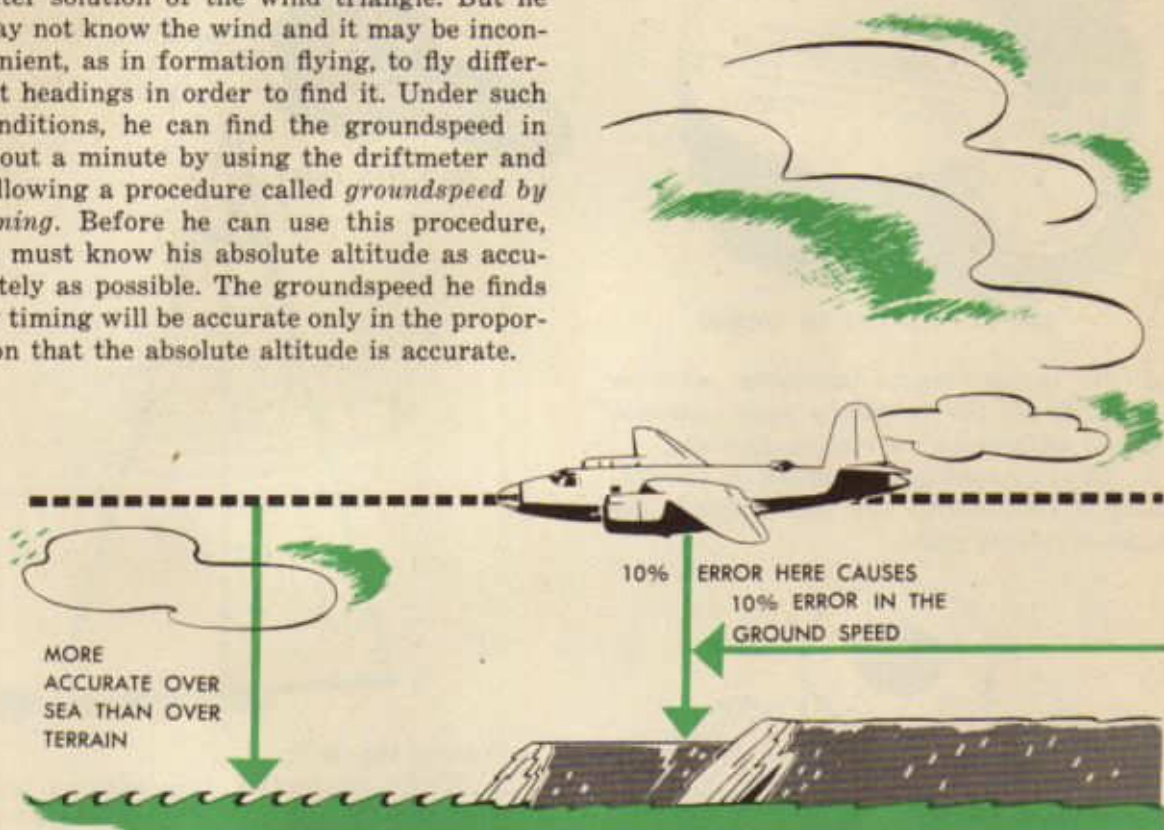

Tactical navigators use three methods of finding groundspeed by timing, one with the B-5 driftmeter and two with the B-2 or B-3. All of these methods are based upon the solution of a triangle by trigonometry for the length of one side. It is not necessary to understand either the principle involved or the derivation of the formulas used in order to use these methods. The easiest method to use employs the B-5 driftmeter. The steps are:

1. Read the drift and leave the indicator plate set with the pointer indicating the drift.

2. With a stop-watch, time to within a tenth of a second, the passage of an object on the ground between the two reticle timing lines.

3. Compute the absolute altitude.

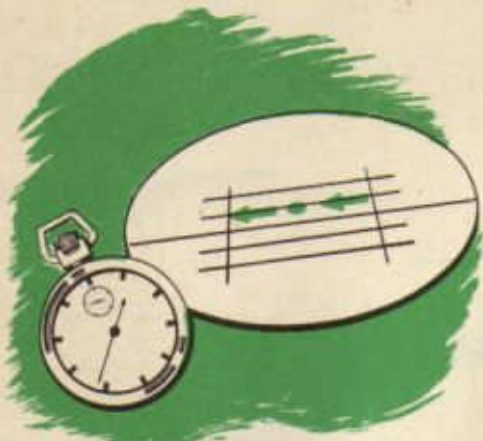

TIME PASSAGE TO 1/10 SECOND

4. On the driftmeter computer, set time in seconds on the revolving scale opposite absolute altitude on the stationary scale.

5. Read groundspeed in knots on the stationary scale opposite the groundspeed line on the revolving scale.

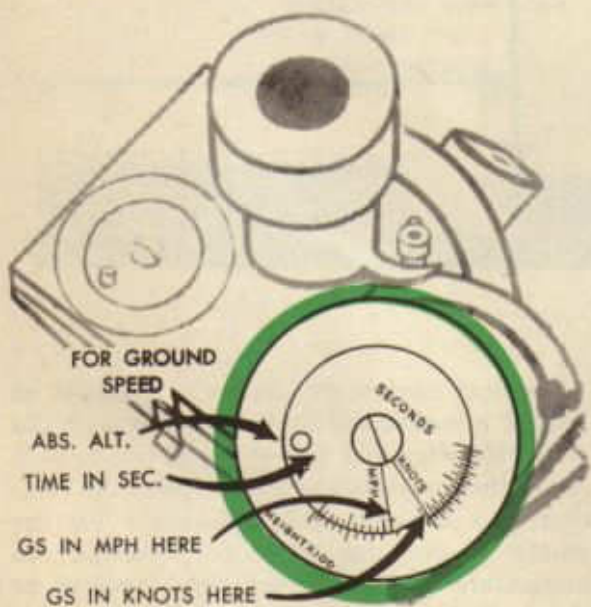

The navigator may use a similar procedure, called *zero angle method*, with a B-2 or B-3 driftmeter, provided the driftmeter has *three* reticle timing lines and provided the navigator knows a constant, K' , for the par-

ticular driftmeter. This constant, K' , is .177 for most B-3 driftmeters, but the navigator must check it as outlined in paragraph d, page 181, of TM 1-205. The procedure for finding groundspeed by this method is as follows:

1. Set line-of-sight at zero, read drift, engage the A-2 clutch, and leave the pointer

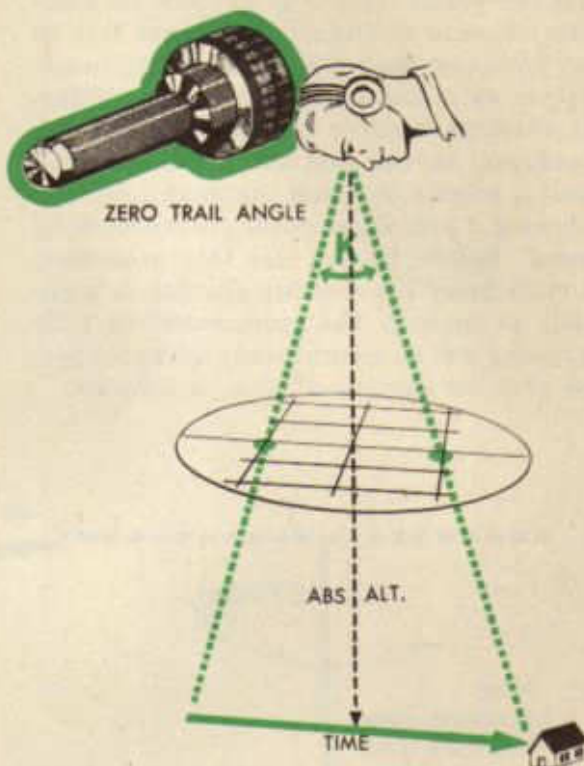

indicating the drift.

2. With a stop-watch, time within a tenth of a second the passage of an object on the ground between the first and third reticle timing lines.

SET DRIFT AND TIME
OBJECT FROM 1st TO
3rd LINE (TO 1/10 SEC.)

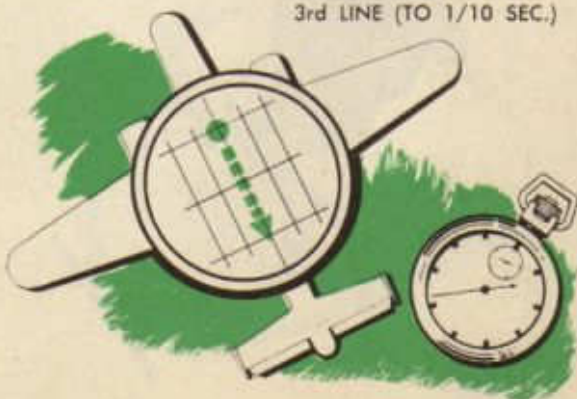

3. Compute the absolute altitude.

4. Substitute the values found in the formula, $GS \text{ (in knots)} = \frac{\text{Ab. Alt.} \times K'}{\text{time in sec.}}$

If, for example, the absolute altitude is 5,000, K' is .177, and the time is 5.1 seconds, the groundspeed in knots is $\frac{5,000 \times .177}{5.1}$ or $\frac{885}{5.1}$ or 173.5 knots.

This method calls for very accurate timing because a small error in timing produces a large error in the resulting groundspeed. It is particularly adapted, however, for finding the groundspeed over water when a wave or a sparkle of light may be visible for only a short time, or when visibility and light conditions prevent the use of another method.

The most practical and most popular method of finding groundspeed by timing is the *trail angle method*, using the B-2 or B-3 driftmeter. This procedure is as follows:

1. Read drift, engage the A-2 clutch, and leave the pointer indicating the drift.

2. Turn the line-of-sight to the detent at 50 degrees and start the stop-watch just at the time some object on the ground passes under the center reticle timing line.

3. Turn the line-of-sight to the detent at 70.9 degrees and stop the watch just as the same object passes under the center reticle timing line again.

4. Compute the absolute altitude.

5. Substitute the values found in the formula, $GS \text{ (in knots)} = \frac{\text{ab. alt.} \times \text{factor}}{\text{time in seconds}}$. The

factor for the angle between 50 and 70.9 degrees is 1. If, for example, the absolute altitude is 5,000 and the time is 25 seconds,

the groundspeed is $\frac{5,000 \times 1}{25} = \frac{5,000}{25} = 200$

knots. The navigator will obtain the same results if he turns the driftmeter around and times the passage of the object from 70.9 to 50 degrees. In actual practice, therefore, he will obtain the time between 70.9 and 50 degrees while the object is in front of the aircraft, turn the driftmeter and obtain the time between 50 and 70.9, average the two times and solve the formula. This will give a more accurate ground speed than a single timing.

The navigator may use any other two angles for this procedure, but he must find

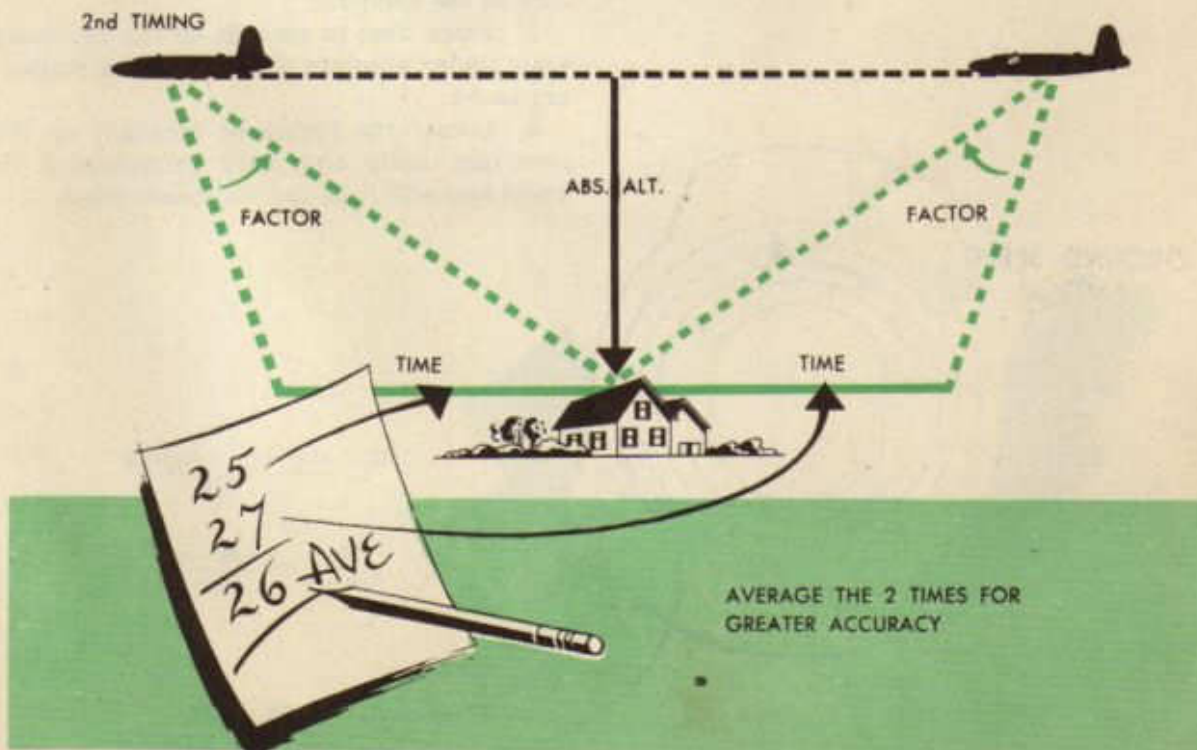

the factor for them. A table of these factors is on page 162 of TM 1-205. The only other angles that the navigator usually uses are 0 and 50; the factor for these two is .706.

CLICK!

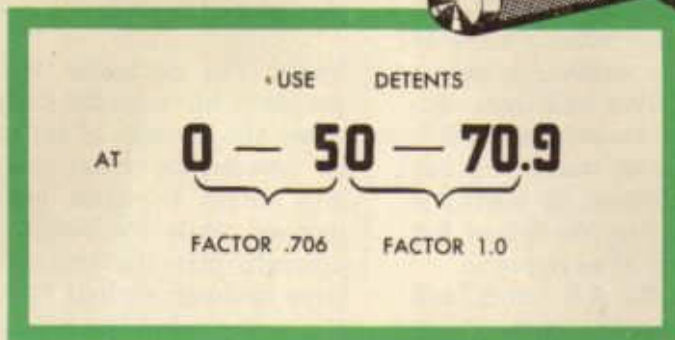

Either of the groundspeed by timing formulas may be solved quickly on the slide rule face of the computer:

1. Place time in seconds on the revolving scale under absolute altitude on the stationary scale.
2. Locate the factor or constant on the revolving scale and read groundspeed in knots opposite it on the stationary scale.

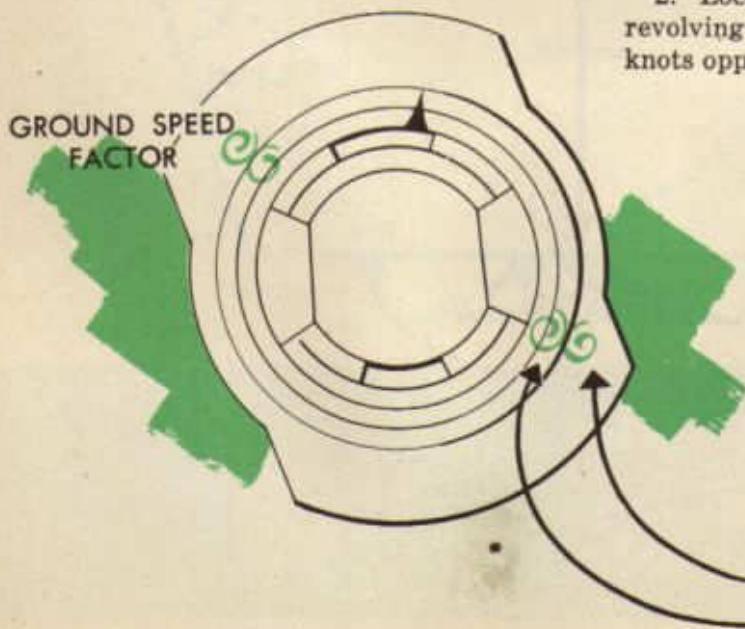

$$GS = \frac{ABS. ALT. \times FACTOR}{TIME}$$

OR

$$\frac{GS}{FACTOR} = \frac{ABS. ALT.}{TIME}$$

ABS. ALT.
TIME IN SEC.

Controlled Groundspeed

When the navigator's problem is simply to guide the aircraft from departure point to destination, the pilot controls the aircraft speed. The pilot is responsible for the safe and economical operation of the engines in flight, and, since the most efficient cruising speed of an aircraft is narrowly limited, the time of arrival at destination ordinarily is a matter of chance, depending upon the velocity of the wind encountered en route.

Tactical considerations often demand, however, that the time of arrival at a definite point not be left to chance. The success of most combat missions depends upon accurate timing. Experience in vast raids over Europe reveals that the percentage of bomb hits and the safety of the aircraft engaged is increased when the formations remain over target for the shortest possible length of time. In these raids, thousands of aircraft from widely separated bases drop their bomb loads on the targets within a very short time. To accomplish this feat, it is necessary for the lead navigator of each squadron to control the arrival of his formation at an initial point so that the concentrated force of the attack is not nullified by an early or late arrival at the target.

The term, *controlled groundspeed*, is misleading. Since the time of arrival at the initial point has been predetermined in the scheme of maneuvers, the groundspeed necessary to maintain en route is determined by time of take-off. The problem, then, is to calculate and control the *indicated air speed* so as to make good the groundspeed required to arrive at destination at the desired time.

There are three steps involved in calculating the required IAS:

1. Determine the track and groundspeed required to arrive at destination at the desired time.

2. Apply the wind to the required track and groundspeed to find the TH and TAS required to make it good.

3. Convert the required TAS to IAS.

The navigator would work through a problem as follows:

Given:

Coordinates of objective

Scheduled time of departure: 2000

Time of arrival at initial point: 2130

Metro wind: 150/20 K

Assumed flight temperature: -20°C

Assumed flight pressure altitude: 30,000



BUT WE MISSED THE FORMATION
BY ONLY 10 MINUTES!

Required:
TH and IAS

To find the required track and ground speed (step No. 1):

1. Plot departure point and destination. Measure course (090) and distance (450 NM). Assume that the course will be the track.

2. Subtract time of departure from time of arrival (2130 - 2000) to find time allowed on course (1.5^h).

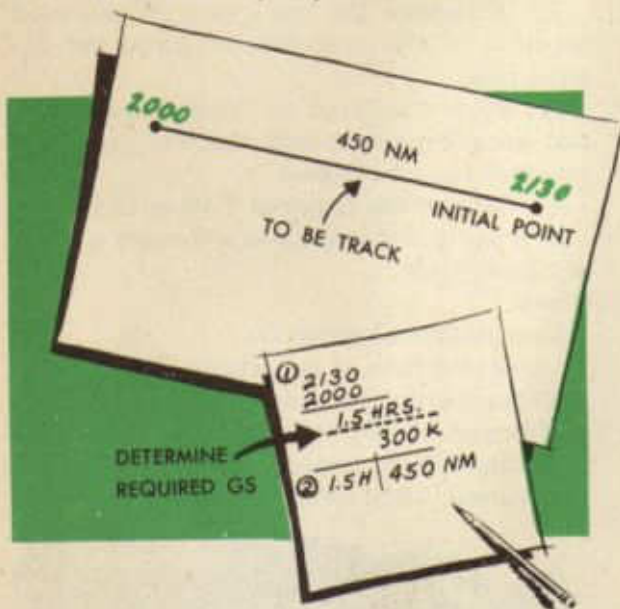

3. Divide distance by time ($\frac{450}{1.5}$) to get required groundspeed (300 K).

To find the required TH and TAS (step No. 2):

1. Apply the wind, metro or actual (150/20 K) as a wind vector to the Tr/GS vector (090/300 K) on chart or computer.

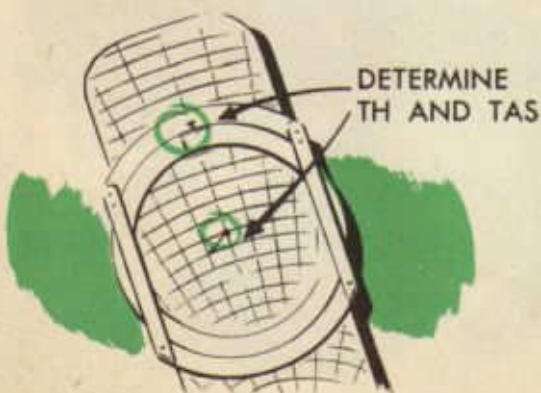

2. Solve the wind triangle and find TH (094) and TAS (311 K).

To convert the required TAS into IAS (step No. 3):

1. Set up flight level pressure altitude (30,000) and temperature (-20 C) on the computer.

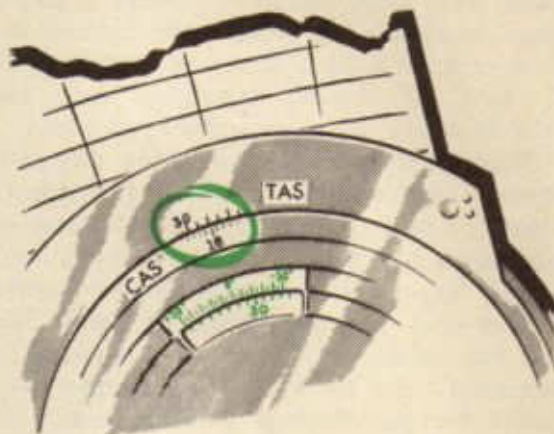

2. Locate TAS (311 K) on the outer scale and read CAS (181 K) opposite it on revolving scale.

3. Locate CAS (181 K) on the airspeed calibration card and read IAS (assume 212 mph).

Thus, the navigator finds that if he flies a TH of 094 at an IAS of 212 mph, he will arrive at destination at the required time.

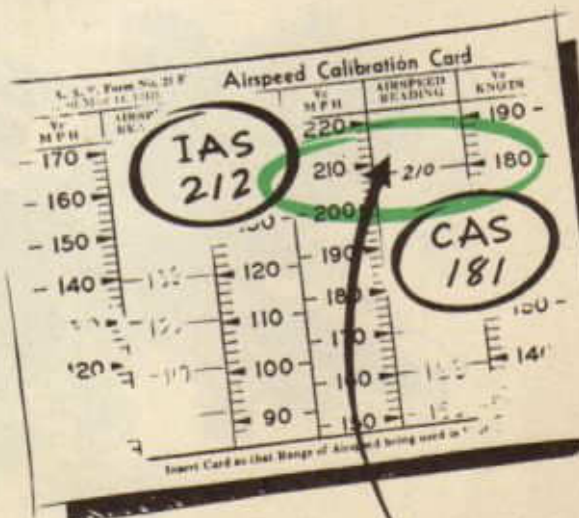

Since a change in any one or more of the variable factors, wind velocity, temperature, or pressure altitude, will affect the ground-speed, the navigator must check during flight. If these factors vary, he must calculate compensating increases or decreases in IAS. If the navigator finds, upon checking his position, that his actual ground position

RE-WORK PROBLEM FROM NEW POSITION IF CHANGE OCCURS

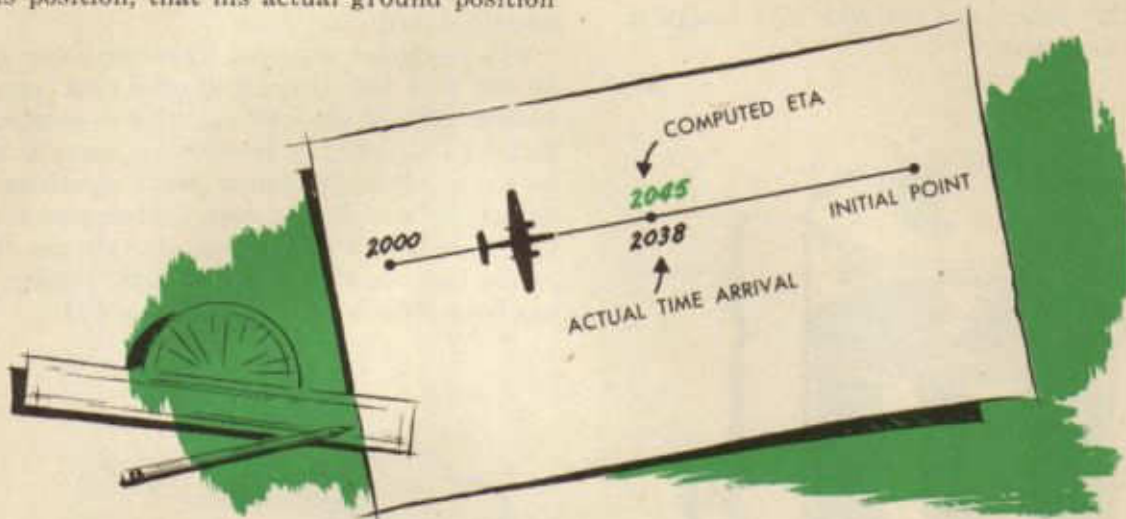

does not correspond with his calculated position, he should re-work the entire problem, using the actual ground position as a new starting point.

Since aircraft engines operate efficiently only within very narrow limits, the navigator cannot vary his IAS over a very wide range. If, upon working his controlled groundspeed problem, the navigator finds that the resulting IAS is too slow for efficient engine performance, he must work out a pattern of

flight that will lengthen his time in the air and permit him to arrive at destination at the proper time. He usually will fly this pattern over enemy territory and for that reason must never take the formation over the same point twice. He generally designs a pattern consisting chiefly of a series of 90 degree turns, alternating to the left and to the right of course.

In addition to the general tactical use outlined above, the navigator will find use for controlled groundspeed in the following situations:

1. On search and patrol missions, to take advantage of daylight and other suitable conditions.
2. On pursuit and torpedo-bomber patrols, to time the attack so that attacking aircraft may be hidden by the rays of the sun.
3. On ferry command and transport missions, to time arrival so that friendly anti-aircraft batteries and radio stations may be notified to expect the formation at a definite time.
4. On rendezvous problems, to insure that neither fighter aircraft nor bombers arrive off schedule.

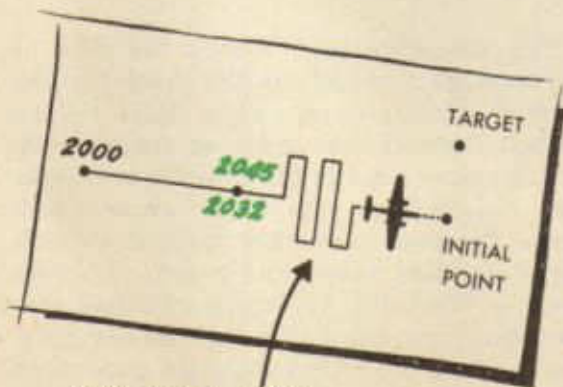

IF IAS TOO SLOW FOR EFFICIENT ENGINE OPERATION FLY PATTERN RIGHT AND LEFT OF COURSE

Fuel Consumption Chart

As a general rule, the navigator knows definitely whether he or some other crew member is going to perform any given task. This is not true, however, for the task of keeping up with the fuel consumption. The pilot, co-pilot, or flight engineer usually looks after this detail, but the pilot may assign it to the navigator.

The rate of fuel consumption is the number of gallons of fuel that the aircraft burns per hour. This rate varies with the type engine, RPM's, altitude, grade of fuel, and other factors. Because the time, and hence the distance, an aircraft can fly is limited by the amount of fuel carried, the navigator must check carefully the rate of fuel consumption in flight.

The navigator must not figure on using all of the fuel the aircraft carries, but must reserve 25% of the total capacity as a safety factor. This reserve provides a margin of safety to off-set changing flight conditions, navigation errors, and other unforeseen factors. The length of time an aircraft can fly on the fuel remaining after the 25% reserve has been deducted is called *big tee* (T).

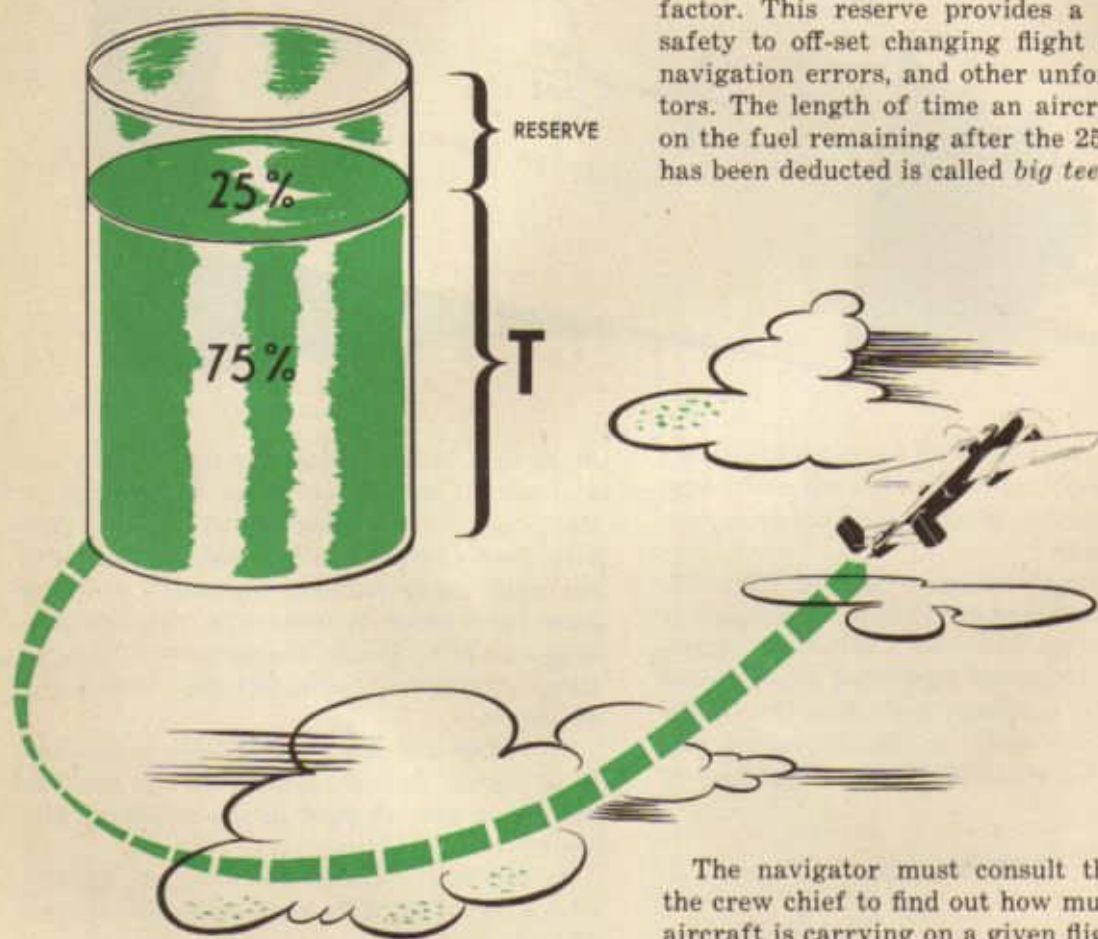

The navigator must consult the pilot or the crew chief to find out how much fuel the aircraft is carrying on a given flight. He can consult the technical order on the aircraft, or a graph or table in the aircraft, to find the fuel consumption rate under given conditions. Bombers and other tactical aircraft carry standard tables and graphs; training craft, a Form No. 41, which give fuel consumption data. From this data the navigator can compute T for the conditions anticipated for a given flight. During flight, then, he must check carefully to see if the anticipated conditions actually are present.

In addition to the fuel consumption rate and T for the flight, the navigator must know, at any time during the flight, (1) the distance flown and the distance remaining to be flown, (2) the amount of fuel consumed and the amount remaining in the tanks, both with and without the reserve, and (3) whether or not it is possible to fly back to departure point. To enable him to know these facts, the navigator constructs a fuel consumption chart and works with it during the flight.

The navigator does the greater part of the work on a fuel consumption chart on the ground before the flight begins. There is little left for him to do on it in the air. Before beginning work on the chart, he must know, in addition to the usual facts about the flight, the metro winds en route. Using these winds,

he divides the route into wind zones, terminating each zone as nearly as possible at each predicted wind shift. Two or three such zones usually cover an entire route.

The navigator works the following problem in the steps indicated:

Given:

1. TC: 186, TAS: 160, Total distance: 1,200 NM
2. Total fuel: 600 gallons; Fuel consumption: 50 gph
3. Zone I: W/v, 320/18 K; distance, 300 NM
4. Zone II: W/v, 086/12 K; distance, 550 NM
5. Zone III: W/v, 286/16 K; distance 350 NM



ZONE ROUTE ACCORDING TO METRO WINDS

Procedure:

1. The fuel scale is set up along the left side of the graph from zero gallons at the bottom of the graph to the aircraft's fuel capacity at the top.

2. The distance scale is marked off along the bottom of the graph from zero nautical miles at the left to destination, which is 1200 NM. The destination line is drawn on right side of graph parallel to the fuel scale line.

3. Lines are drawn perpendicular to the distance scale at proper intervals to separate the wind zones. Each wind zone is labeled along the bottom of the graph.

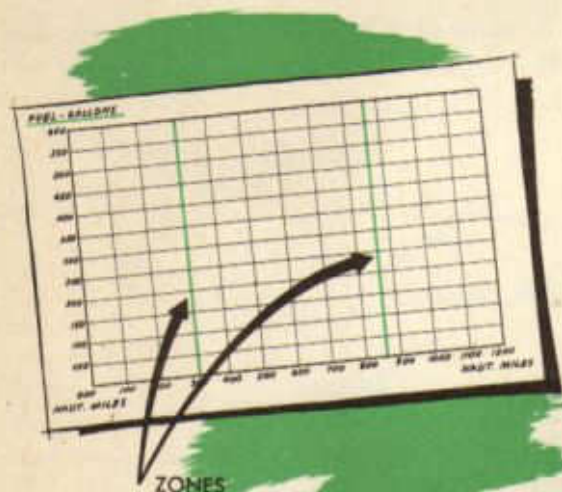

4. The Full Tank Line is labeled along the bottom of the chart.

5. Draw the Dry Tank Line parallel to the Full Tank Line at a point on the fuel scale equal to the aircraft's total fuel capacity.

6. Below the Dry Tank Line draw a parallel *Reserve Fuel* Line at a point on the fuel scale corresponding to 75% of the aircraft's total fuel capacity.

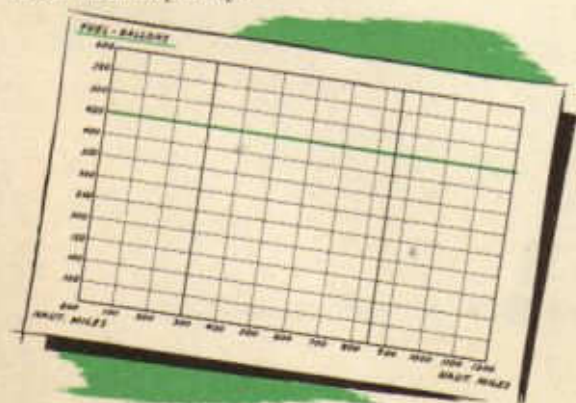

7. The TAS, TC, and wind are placed on the computer and the GS for each zone is calculated. GS and distance are placed on the computer to find the time to run in each zone.

8. The total gallons of fuel consumed is calculated for each zone. This is done by placing the fuel rate on the outside scale of the computer, opposite the black arrow of the inner scale. Read total gallons consumed on the outside scale, above the time.

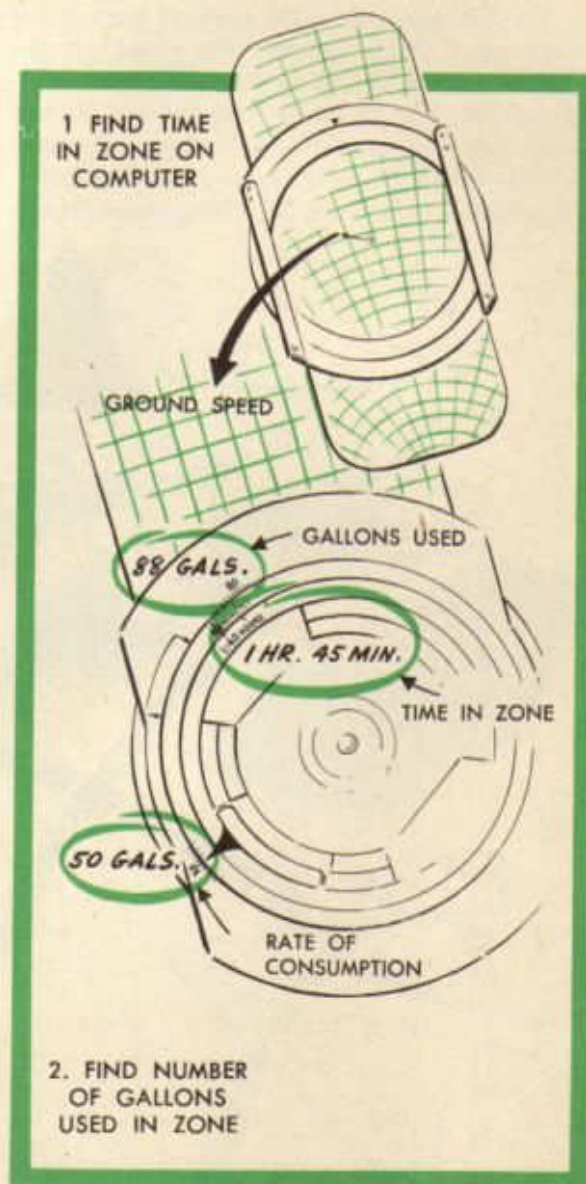

9. The amount of fuel consumption is plotted against distance for each zone, upward from the full tank line.

10. Then, with the full mark as an origin, a solid line is drawn connecting the plotted points. This is the *Ahead Line*, which shows the fuel already consumed and also the total fuel remaining at any given distance along the course.

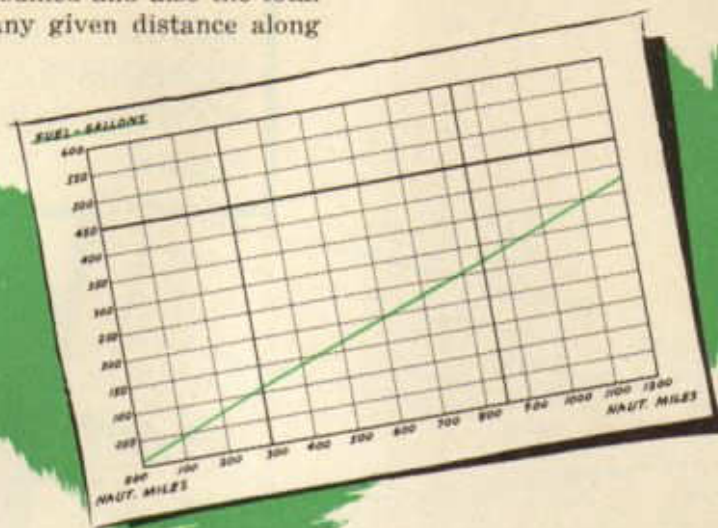

11. The amounts of fuel consumed for each zone of the return trip are calculated, using the same winds and the reverse course for each zone.

12. The amount of fuel consumed on the return flight is plotted against distance for each zone starting from the Dry Tank Line.

13. Then, with the Dry Tank Line as an origin, the plotted points are connected. This is the *line of no return*, since the aircraft

must turn back to departure before the Ahead Line intersects this line, in order to reach the departure point safely. Beyond this intersection point the aircraft must continue to destination or an alternate base.

14. The line of no return is then replotted, using the reserve fuel line as an origin. This becomes the *Line of Safe Return*, since the aircraft can return to base within the safety fuel margin from the Point of Intersection of the Ahead Line and the Line of Safe Return.

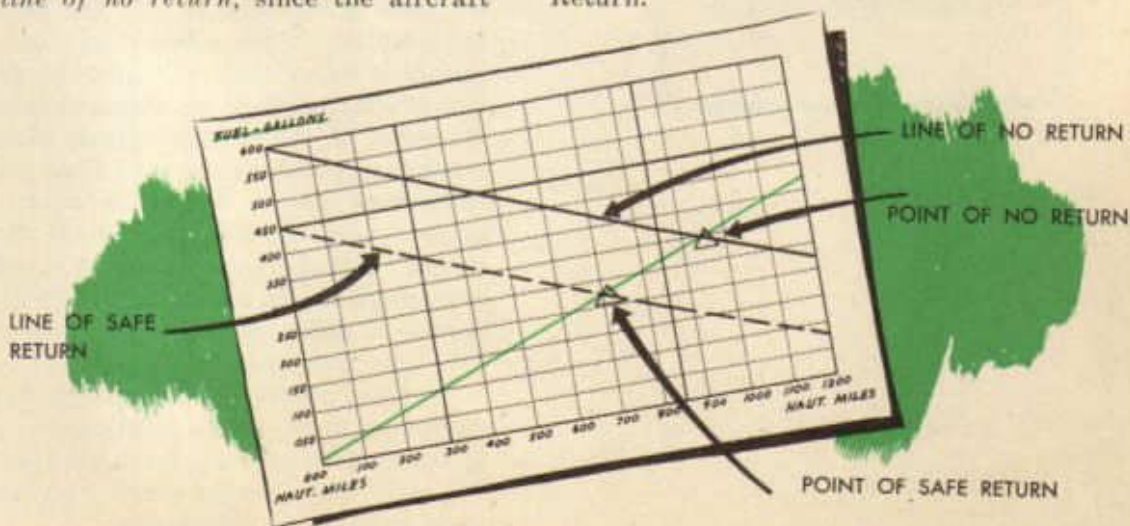

15. Add an hour scale to the fuel scale in order to determine the time of arrival at the Line of Safe Return and at destination.

ACTUAL FLIGHT
CONSUMPTION
PLOTTED DURING
FLIGHT



HOUR SIDE ON
FUEL SCALE TO
DETERMINE ETA'S

Having constructed the graph, the navigator uses it in flight to plot the actual fuel consumption. If the actual fuel consumption line falls below that estimated for the original graph, the flight is continued as planned. However, if the original graph shows that more fuel is being consumed than predicted, immediate checks should be made to discover reasons for changes. Winds should be checked and compared to metro forecasts. A new graph should be constructed if winds are shown to differ radically from metro data. The new graph can then be used as a basis for judging whether to alter flight plans. The navigator must decide whether to continue to destination or turn back between points (C) and (A). Beyond point (A) the plane must continue to destination.

FUEL CONSUMPTION CHART

TIME FUEL

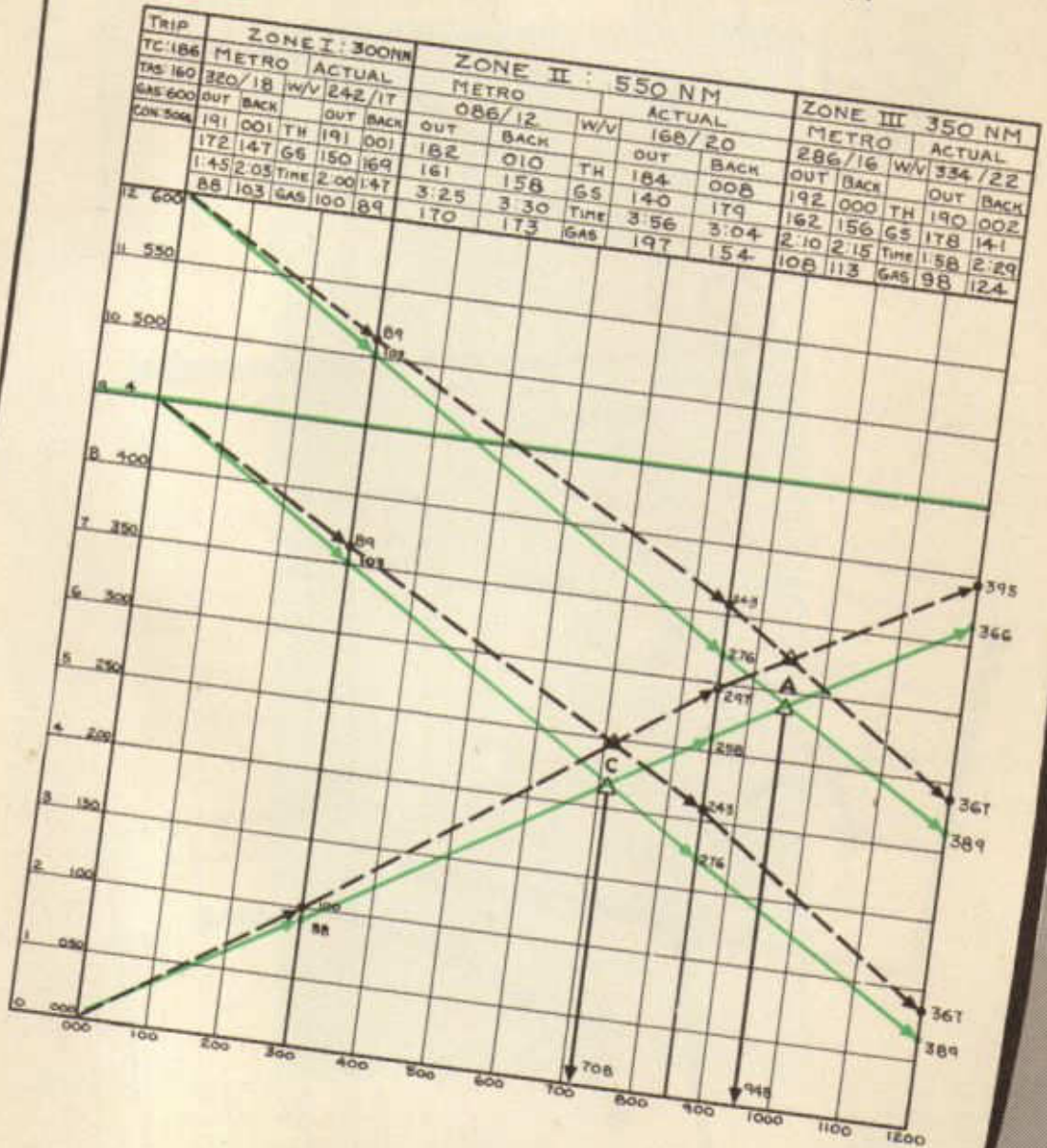

GREAT CIRCLE FLYING



1

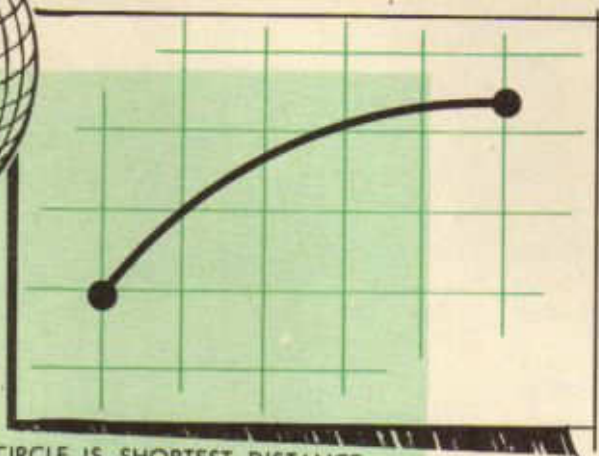

GREAT CIRCLE IS SHORTEST DISTANCE BETWEEN 2 POINTS

2

YOU CAN NOT FLY A GREAT CIRCLE AS IT CONSTANTLY CHANGES COURSE

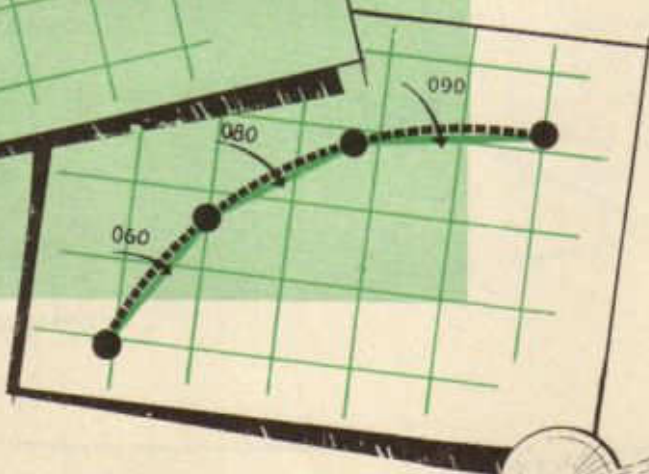
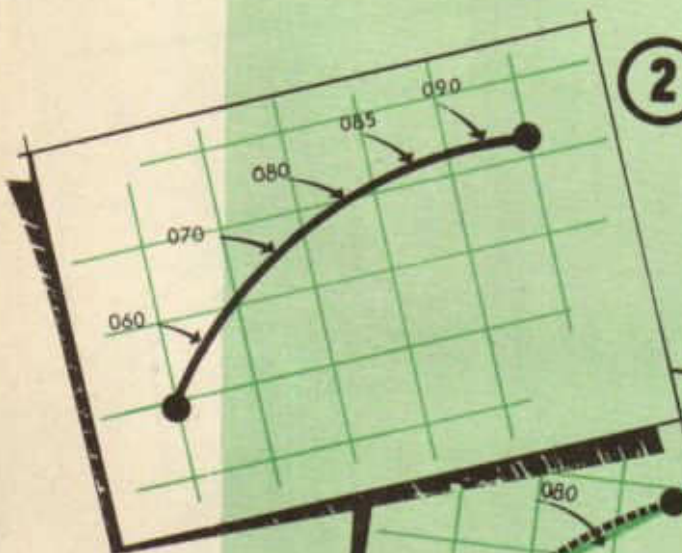

3

YOU CAN FLY A SERIES OF CHORDS OF A GREAT CIRCLE



- 1** TO DETERMINE RHUMB LINE
CHORDS PLOT COURSE ON GREAT CIRCLE
PLANNING CHART

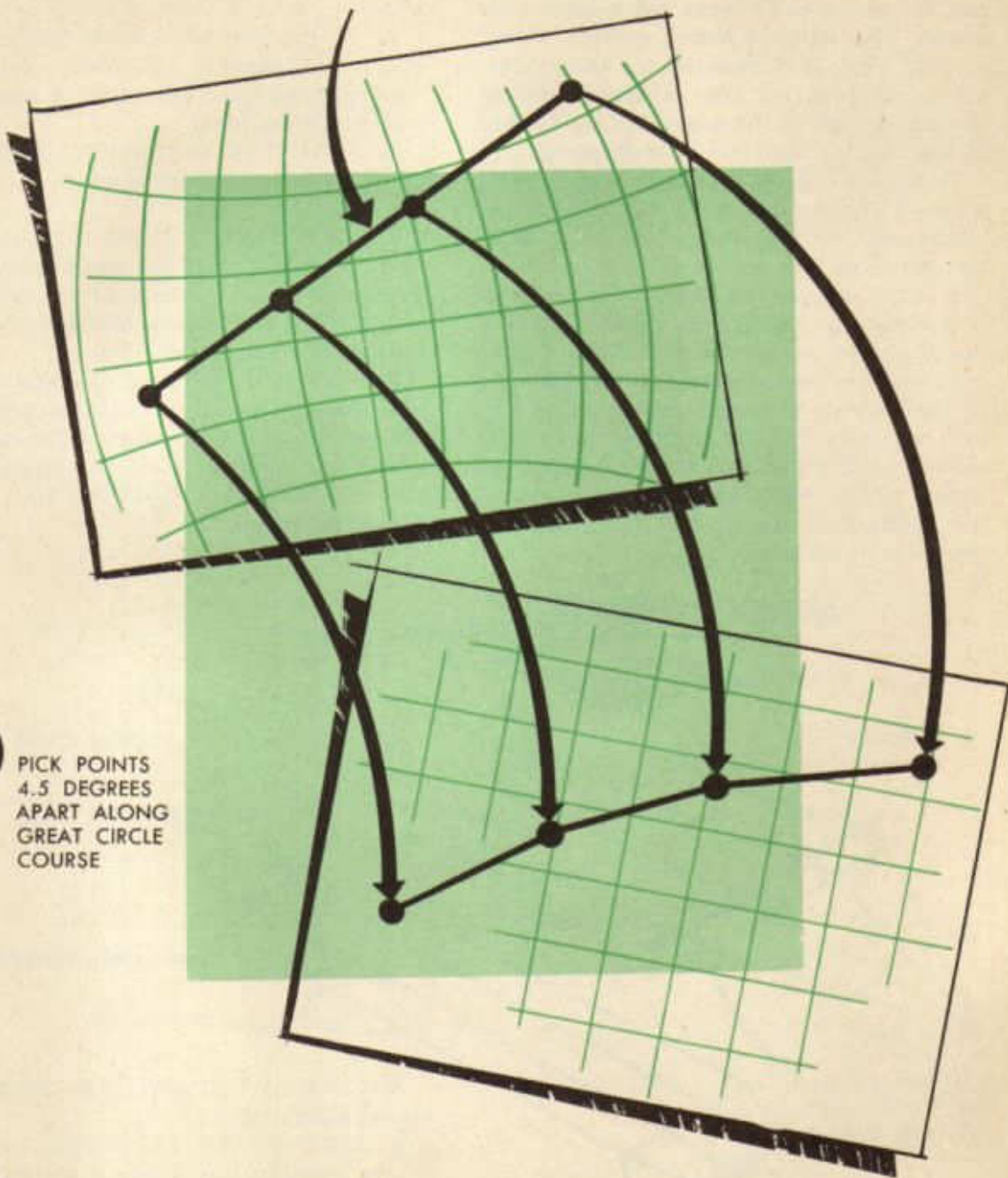

- 2** PICK POINTS
4.5 DEGREES
APART ALONG
GREAT CIRCLE
COURSE

- 3** TRANSFER POINTS TO MERCATOR
CHART COURSES FOR RHUMB LINE

Patrol and Search

After flying a few missions, every navigator realizes the value of a systematic method of search. When the destination does not show up on ETA, in reduced visibility, it may be advisable to carry out a systematic search. The simplest search pattern should be used, since it is essential for the navigator to continue his DR navigation during the search, and at the same time, to be sure of locating his objective or destination.

To distinguish between search and patrol a *search mission* is a flight executed for the purpose of locating enemy forces known or thought to be in a certain area.

A *patrol mission* is a flight for the purpose of maintaining continuous observation of a line to detect the approach of enemy forces.

In order to have a complete understanding of the contents of search and patrol orders, it is necessary that the navigator be familiar with the (1) terms appearing in search and patrol orders, (2) factors affecting search, (3) methods of search, and (4) some common search patterns.

The following terms will be most frequently encountered in search and patrol orders:

1. **SCOUT**—An airplane engaged in a search.
2. **SCOUTING LINE**—The line on which scouts are located in a formation suitable to conduct a scouting operation in accordance with a definite plan.
3. **SCOUTING DISTANCE**—Distance in miles between adjacent aircraft on a scouting line.
4. **SCOUTING FRONT**—Distance in miles measured along the scouting line from the extremity of visibility on one end of the scouting line to the extremity of visibility at the opposite end of that line.
5. **POSITION CIRCLE**—Locus of possible position points of a force which has proceeded a known or assumed distance from a known or assumed point of departure.
6. **SCOUTING COURSE**—True course steered by scouts.

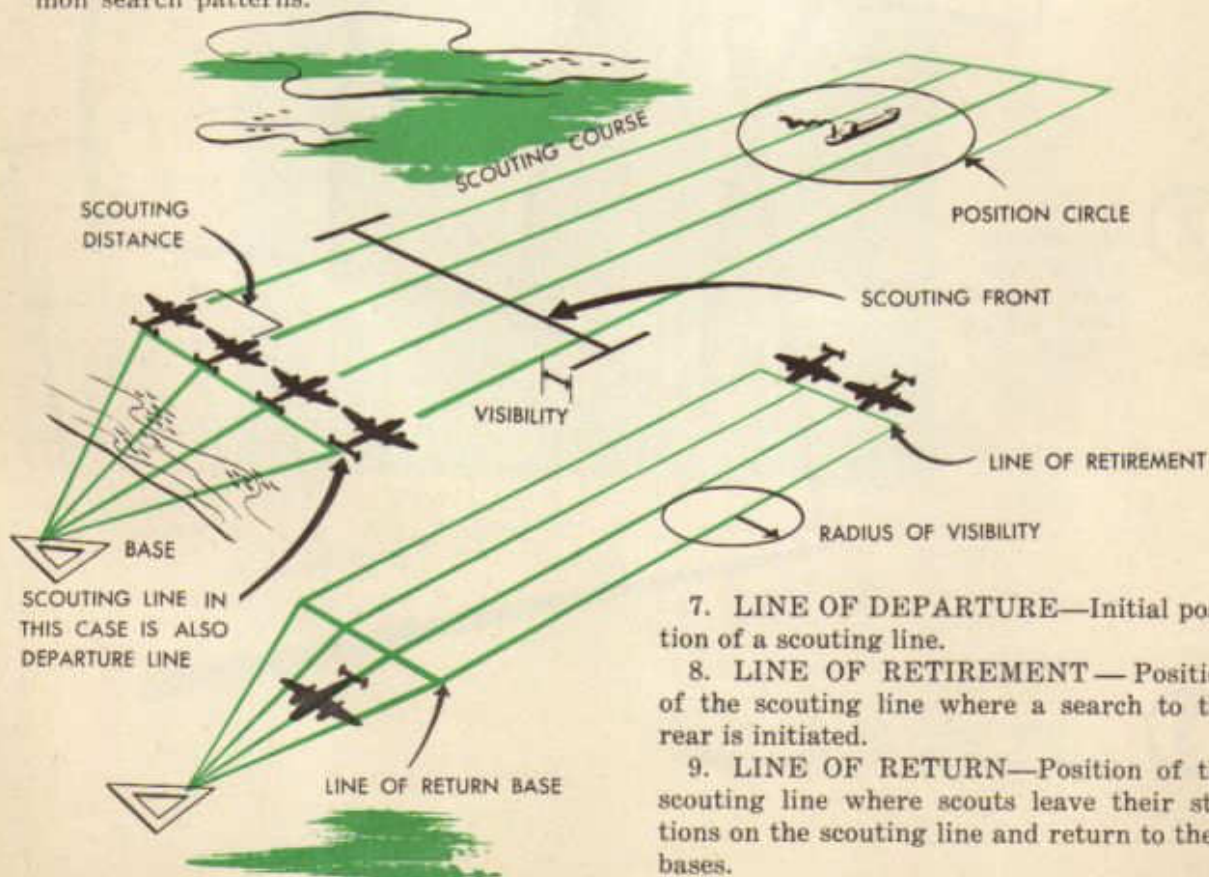

10. **RADIUS OF VISIBILITY**—Radius of a circle from the center of which the object to be observed can be seen in any direction.

Factors affecting a search are as follows:
1. Number of aircraft available for search.

2. Characteristics of searching aircraft as to range and speed.

3. Location of alternate bases from which search operations may be conducted.

4. Size and shape of area to be searched.

5. Time available for search.

6. Weather conditions.

7. Navigational errors—The scouting distance normally is based upon the estimated radius of visibility in the search area for the type of objective sought, less the allowance for navigational errors; therefore, these errors influence the number of scouts required for the search of a given area. To allow for the navigational errors, the scout-

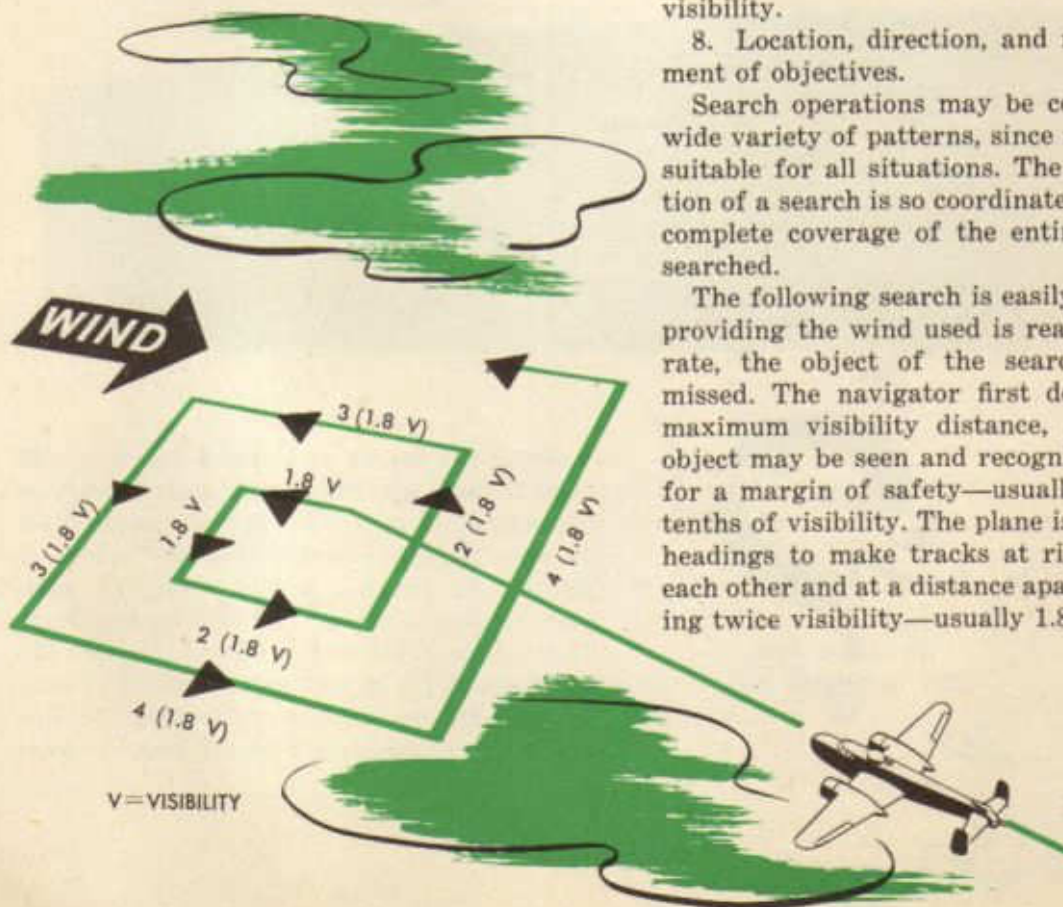
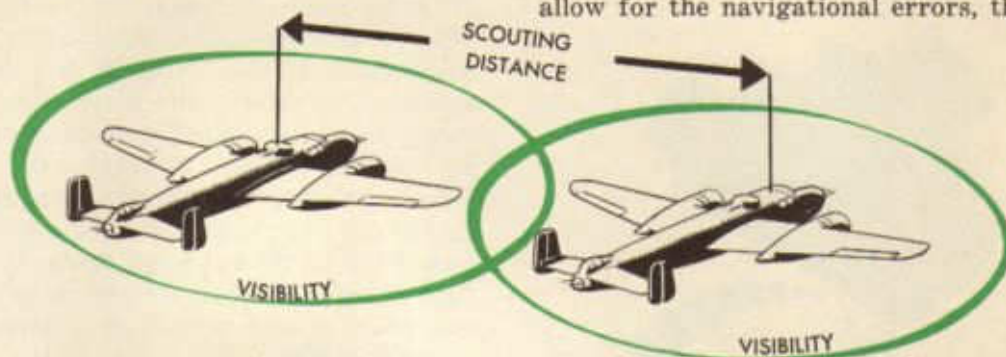

ing distance should be less than twice the visibility.

8. Location, direction, and rate of movement of objectives.

Search operations may be conducted in a wide variety of patterns, since no one plan is suitable for all situations. The whole operation of a search is so coordinated as to insure complete coverage of the entire area to be searched.

The following search is easily applied, and providing the wind used is reasonably accurate, the object of the search cannot be missed. The navigator first decides on the maximum visibility distance, at which the object may be seen and recognized, allowing for a margin of safety—usually using nine-tenths of visibility. The plane is flown on the headings to make tracks at right angles to each other and at a distance apart not exceeding twice visibility—usually 1.8 visibility.

In order to avoid precomputing the courses or making last minute calculations, the courses made good are best arranged up, down, and across the wind. It will then be necessary to calculate the drift and ground speed on only one cross wind and track, since the groundspeed and drift either way are the same (though the drift is of opposite

sign). Up- or down-wind tracks will have no drift, and the groundspeed is simply the true airspeed \pm the wind speed. This pattern is the *fixed square search*.

On looking for a moving object, such as a ship, the search should be arranged so that the track made good remains square related to the moving object. This is its chief difference from the fixed square search. It is called the moving or relative square search. It is necessary to know the extent of the object's movement, then to calculate the relative wind. If the tracks of the plane are arranged up, down, and across the relative wind, the square search is made to move bodily with the object. Naturally the calculations are slightly complicated since the actual tracks can only be deduced by applying the true wind to the headings flown. It is most convenient to keep an air plot, then to apply the wind at any minute to determine the ground position.

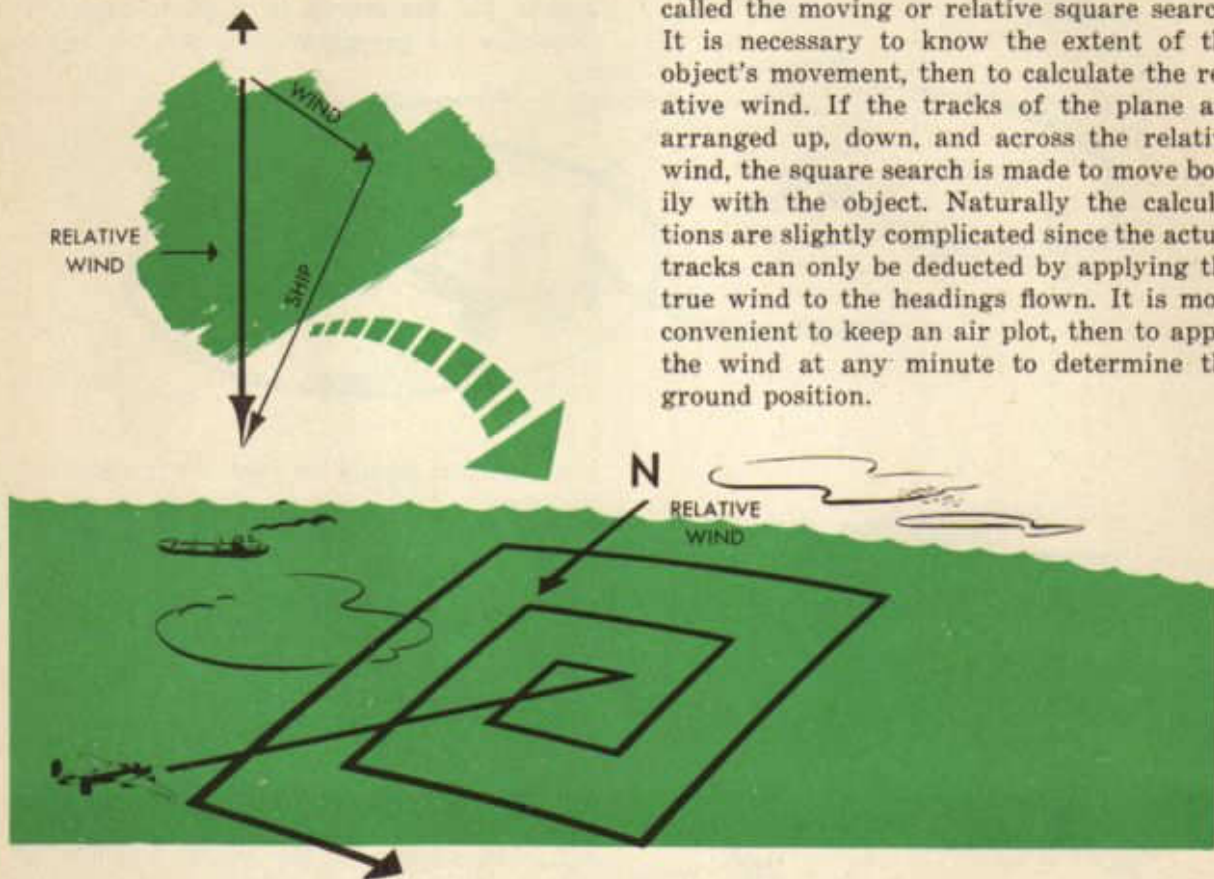

Along the search and patrol missions, DR must be kept up. The correct course must be maintained at all times. The navigator must be able to estimate position of forces, if sighted, in relation to his plane. At each turn he should get a wind on two headings. Throughout his search or patrol mission, the navigator must, at all times, be able to determine his ground position and be able to maintain a course which will insure him of locating his objective.

Interception

RELATIVE MOTION

In the preceding sections the motion of the aircraft has been considered with reference to fixed points on the earth's surface. The plane leaves from a fixed point of departure and arrives at a fixed destination, and its progress may be measured with respect to either one of these fixed points. The student has learned to calculate the plane's motion in terms of course and speed and to conduct the aircraft to destination by applying such calculations. In this section will be explained the motion of an aircraft relative to moving objects with particular reference to the problem of interception which, in general terms, consists of conducting the plane to a moving destination.

While the motion of a plane which departs from a fixed point is *relative motion* with respect to that point, it is also represented by the plane's course and speed over the surface of the earth and may be called *terrestrial* or *geographic* motion. In aerial navigation the term, "relative motion," invariably refers to the movement of a plane with respect to a moving object.

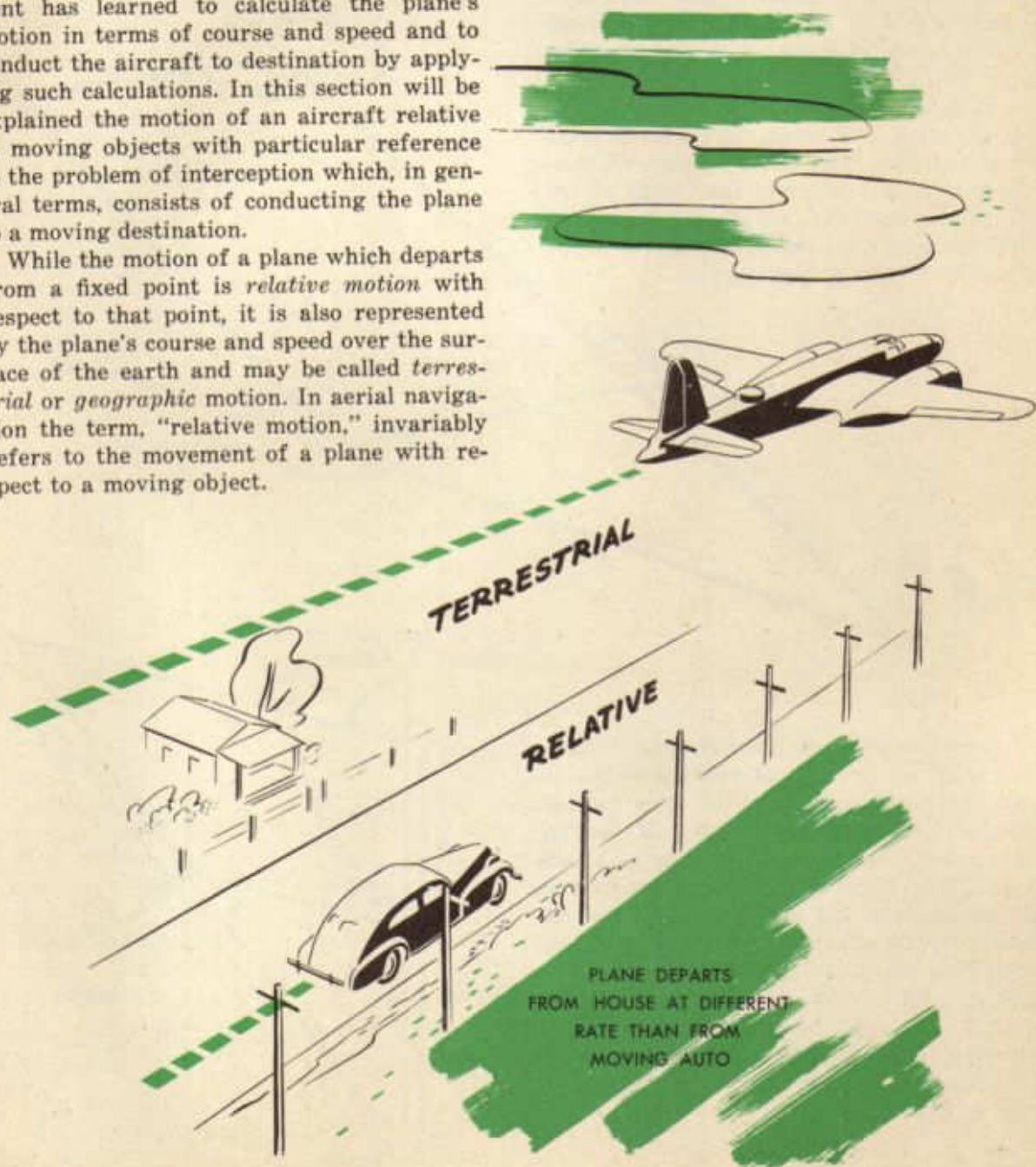

In the diagram two planes, A and B, depart from a common point at the same time; A is making good a course of 000 and B a course of 045. It is immaterial whether the groundspeed of each plane is the same, so let it be assumed that A's speed is 90 K and B's 150 K. At the end of ten minutes A and B are respectively 15 and 25 NM from departure point. Relative motion now exists between the two planes. The direction that B has traveled with respect to A is expressed as an angle at A measured clockwise from TN to a line joining the ten minute positions of the two aircraft and similarly, the direction of relative motion of A with respect to B is the angle at B measured clockwise from TN to this line. The term, distance of relative motion, is applied to the length of the line (d) between the two planes. At the end of twenty minutes A and B will have traveled 30 and 50 NM from departure.

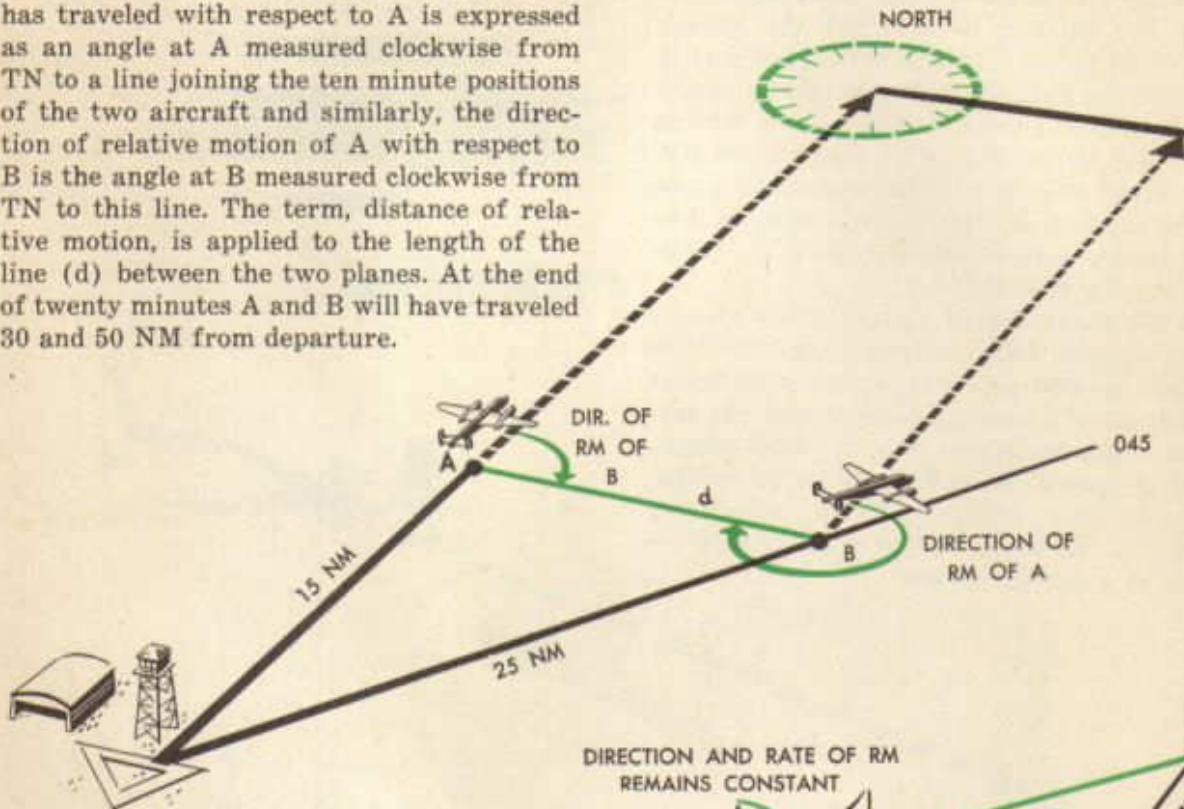

By the geometry of similar triangles, it is evident that the direction of relative motion of each plane with respect to the other has not changed and that the distance of relative motion ($2d$) has doubled. As long as planes A and B continue to make good the courses of 000 and 045 and do not change groundspeed, the direction of relative motion will remain constant and the distance of relative motion will increase by the same amount during each equal period of time. The rate at which the distance between the two planes is increased is termed the *rate of opening* or *rate of departure*.

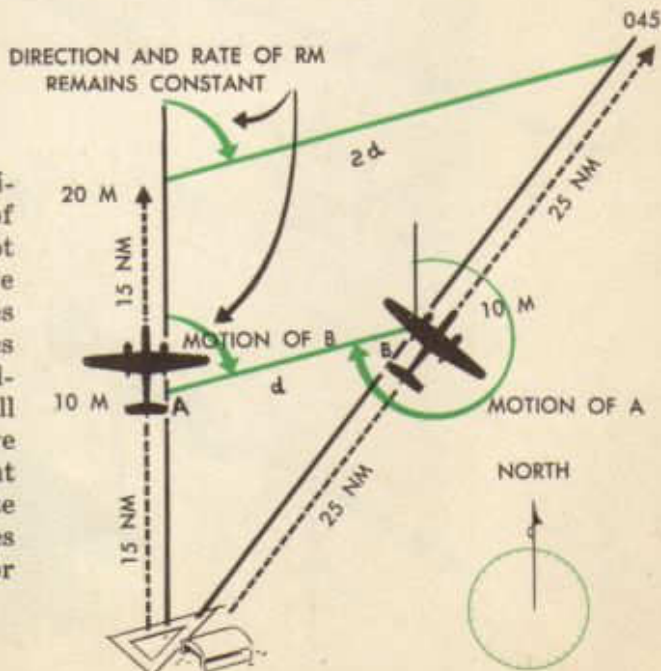

The preceding explanation and diagram illustrate the constant bearing principle of relative motion which may be summarized as follows: The direction and speed of relative motion between two objects which move on diverging courses from a common point will remain constant as long as they maintain constant courses and speeds. The corollary of this principle, which underlies the solution of the interception problem, holds that whenever two objects maintaining constant courses and speeds are moving in such a manner that they will arrive at a common point at the same time, or, in other words, that interception will occur, the direction and speed of relative motion of one object with respect to the other will remain constant.

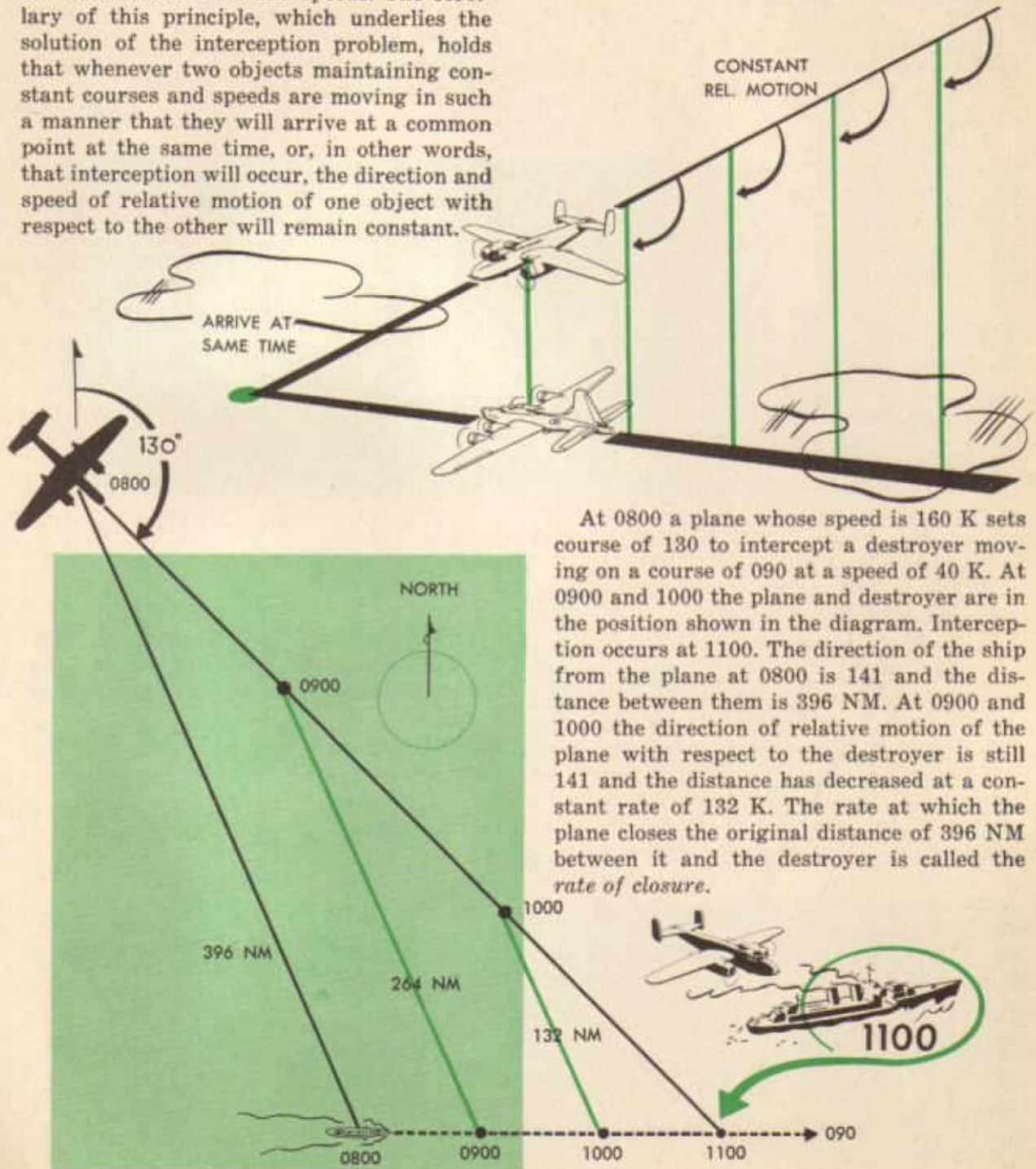

At 0800 a plane whose speed is 160 K sets course of 130 to intercept a destroyer moving on a course of 090 at a speed of 40 K. At 0900 and 1000 the plane and destroyer are in the position shown in the diagram. Interception occurs at 1100. The direction of the ship from the plane at 0800 is 141 and the distance between them is 396 NM. At 0900 and 1000 the direction of relative motion of the plane with respect to the destroyer is still 141 and the distance has decreased at a constant rate of 132 K. The rate at which the plane closes the original distance of 396 NM between it and the destroyer is called the *rate of closure*.

Given the conditions in the preceding illustration, any course other than 130 would effect interception at a point on the destroyer's track ahead or behind the vessel itself. For instance, if a course less than 130, say 111, had been taken up at 0800, the plane would have crossed the ship's track at A, which is ahead of the destroyer.

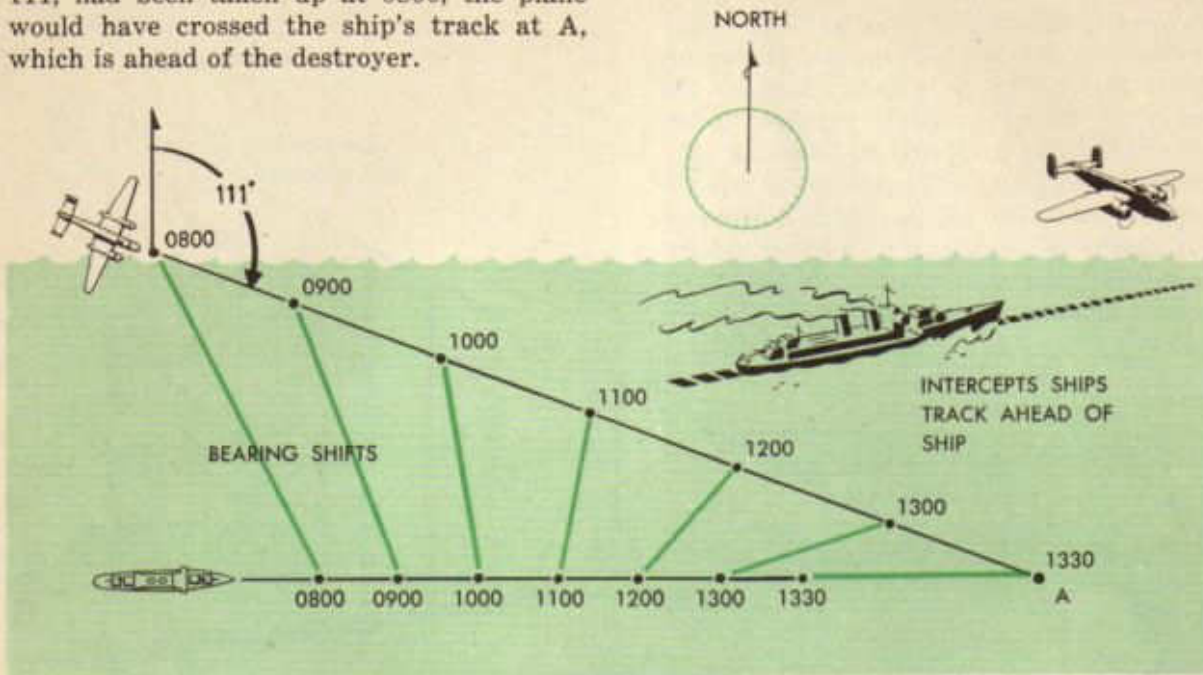

And if a course greater than 130, say 145, had been flown, the plane would have been behind the destroyer at the time of crossing its track.

In both cases the line of bearing between the plane and ship constantly shifted direction.

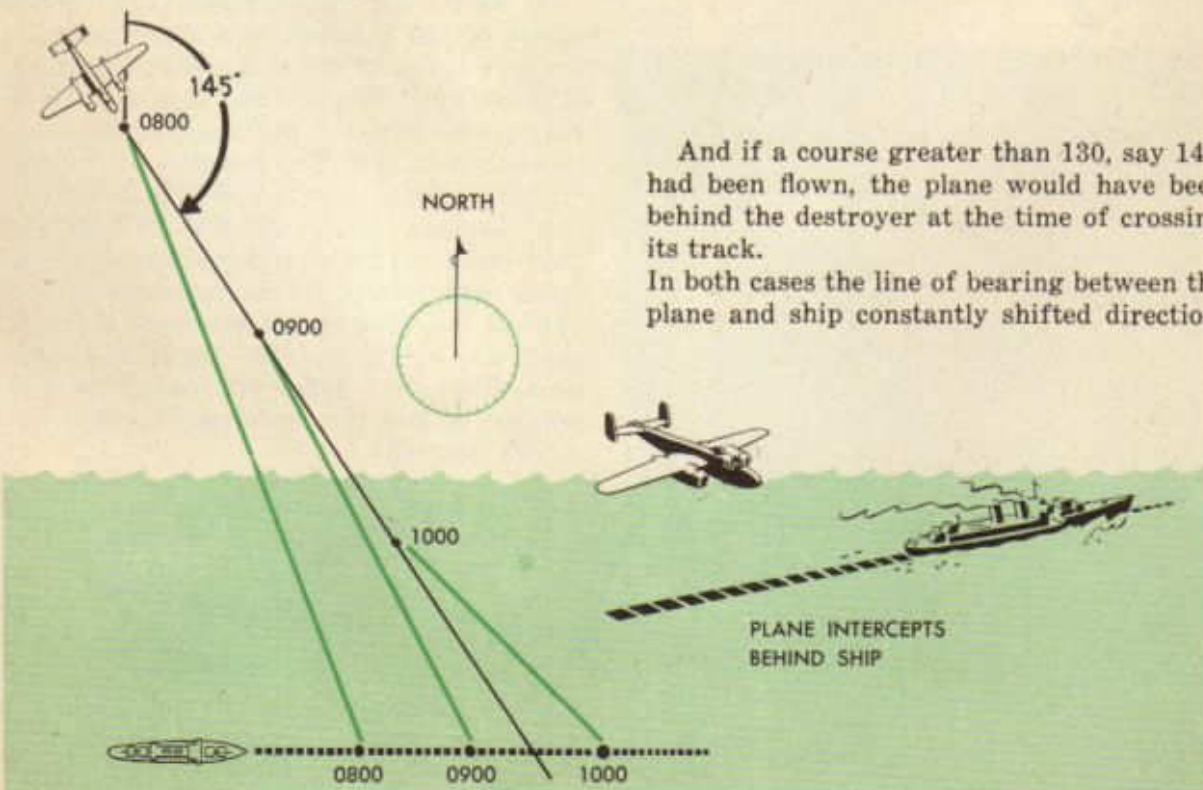

THE INTERCEPTION PROBLEM

The interception problem consists in determining the course which will enable an aircraft to "close on" or intercept a moving target in the shortest possible time. As already shown, interception will occur only if a constant bearing is maintained between plane and target. Thus the problem is resolved into a calculation of the course which will maintain such a constant bearing. This is usually accomplished by the navigator graphically on a Mercator chart.

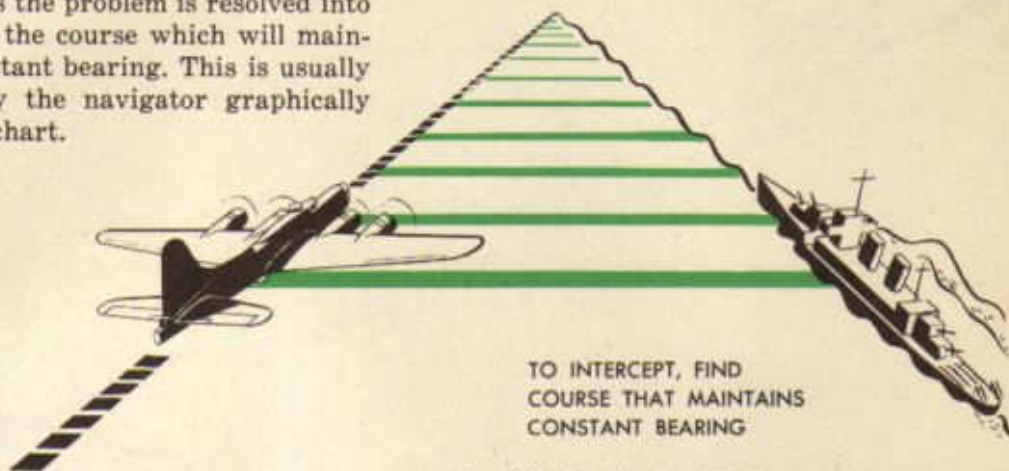

The bearing which must be maintained throughout interception is that which exists between plane and target at the time the course to intercept is taken up. Therefore, in addition to the DR position of the plane, the position of the target must be known. The line drawn between the plane and target at the time it is desired to begin interception is called the *first line of constant bearing* and forms the starting point of all problems.

To complete the interception diagram, three factors must be known:

1. The course and speed of the target. This is necessary in order that the position of the target may be plotted at any instant of time.

TO COMPLETE INTERCEPTION
KNOW



2. Wind velocity. Without this, the heading to make good the course to intercept cannot be determined.

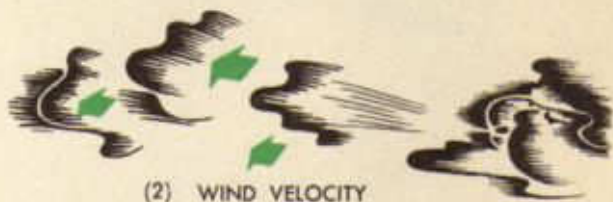

3. The TAS which can be maintained by the interceptor.

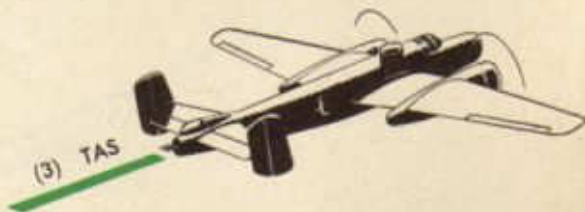

The steps in the solution of the interception problem are best illustrated with the aid of a diagram. The following represents a typical interception occurring in more than one hour. The line AB represents the course (075) of a vessel which departed from A at 0800 at a speed of 20 K. The navigator decides to begin interception at 1000 from C. The wind velocity is 045/25 K and the air-

speed to be maintained during interception is 150 K. With this data the problem is solved as follows:

1. The simultaneous position, that is, the 1000 position of the ship, is established and a line drawn connecting it and the plane. This is the first line of constant bearing and is shown in the diagram by the line CD.

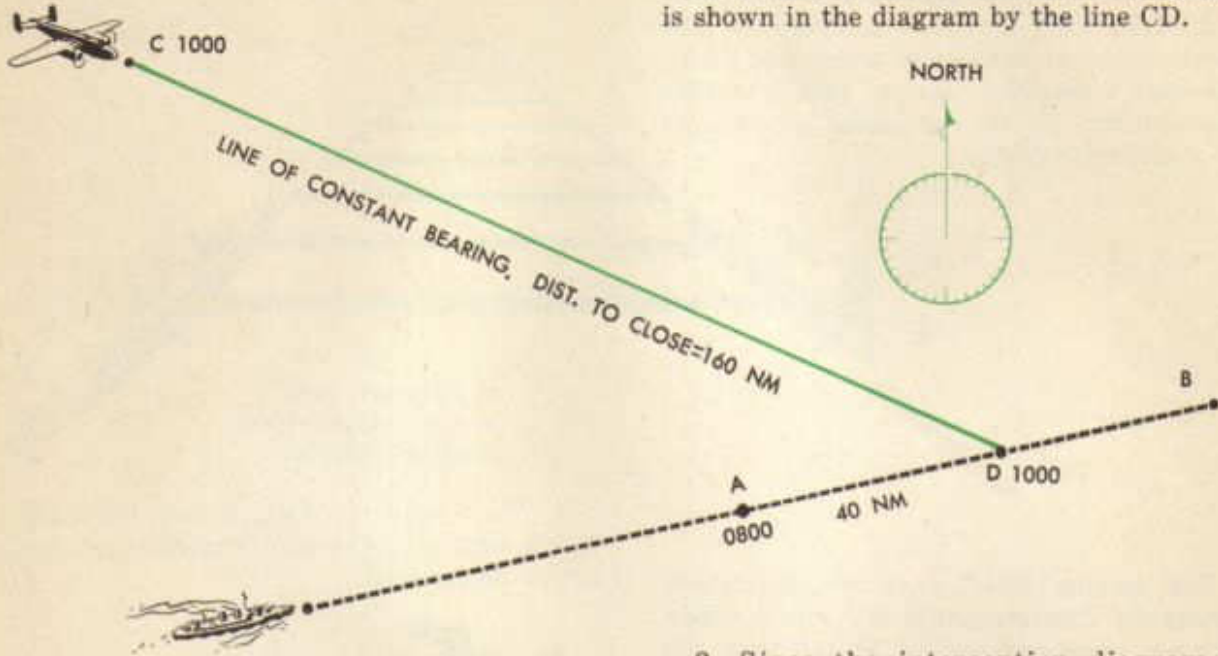

2. Since the interception diagram is worked on an hourly basis a line called the *line of parallel bearing* is drawn parallel to the first line of constant bearing to intersect the ship's track at its 1100 position (D'), 20 NM ahead of D.

3. Lay in the wind for one hour so that the tail of the vector lies on the initial position of the interceptor (C).

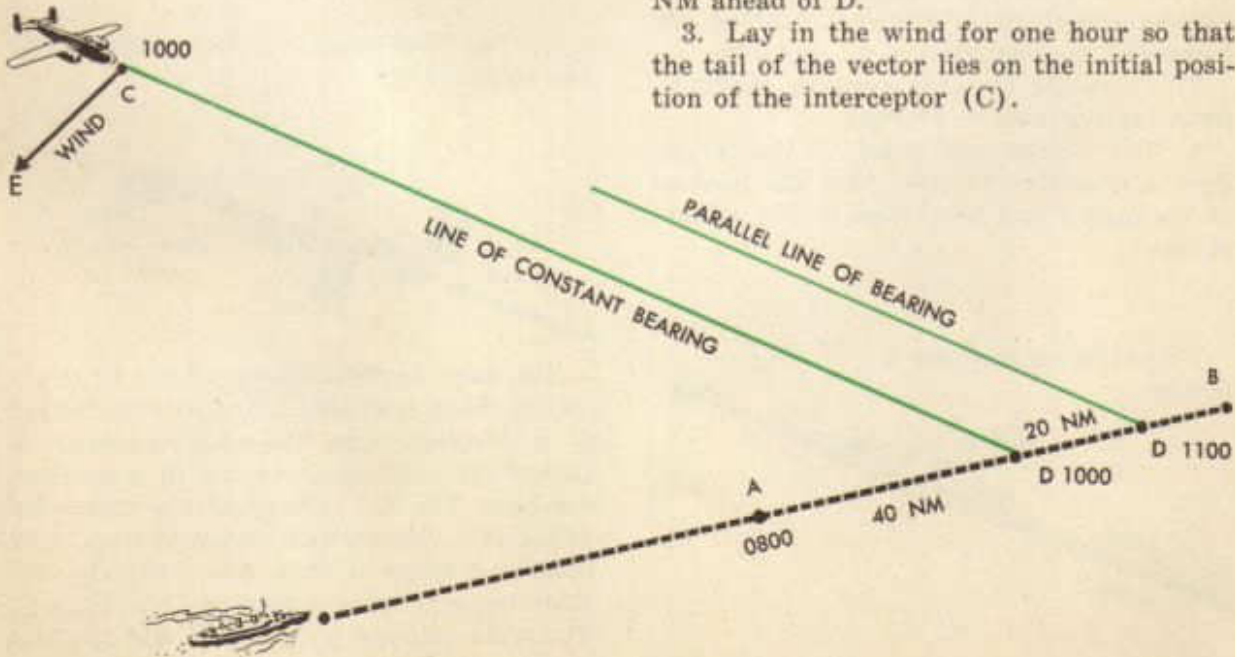

4. Using TAS as a radius, describe an arc from the end of the wind vector (E) intersecting the parallel line of bearing at F.

5. Draw a line from C through F intersecting the course of the target at point I.

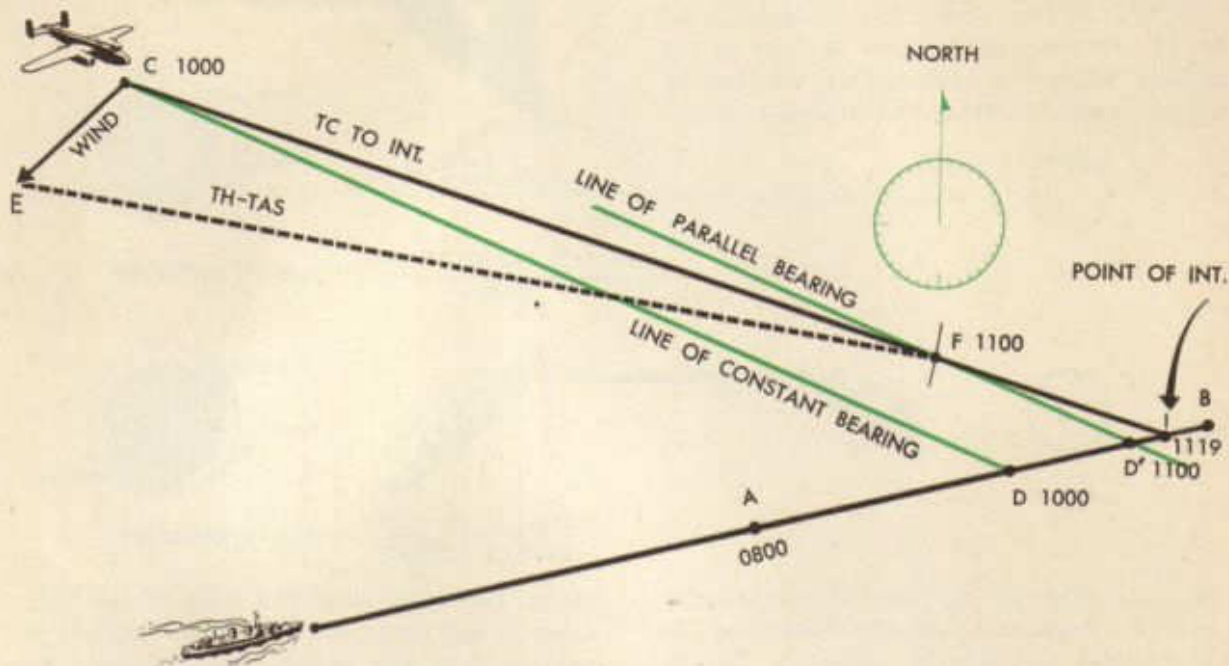

The interception diagram is now complete. The triangle CEF is the familiar triangle of velocities, CF representing the track and GS, CE, the given wind, and EF, the TH and TAS. Since the triangle is drawn on an hourly basis, the point F represents the one hour or 1100 position of the plane. The bearing between plane and ship at 1000 has not changed at 1100; therefore F must lie on the course to intercept. From the interception diagram the following data can be determined:

1. Course to intercept represented in the diagram by the line CFI = 107.
2. GS to intercept represented by the length of CF = 138 K.
3. Heading to intercept, EF = 098.
4. Distance to intercept, the length of CFI = 182 NM.
5. Time to intercept, found from applying the time-speed-distance formula: $\frac{CFI}{CF} =$ time to intercept in hours = 1^h 19^m.

6. The time of interception, found by adding the time to intercept to the initial time (1000 + 1^h 19^m), is 1119.

7. If the diagram has been drawn on a Mercator chart, the point I represents the coordinates of interception.

There are two ways by which the correctness of the time to intercept as determined above may be checked.

1. The distance traveled by the target during interception divided by its speed should result in the time to intercept. This method is not as satisfactory as the *rate of closure* method which follows, since the scale to which interception diagrams are usually drawn is so small that accurate measurement of the distance traveled by the target is difficult. In the illustrative diagram the vessel was found by measurement to have traveled 26½ NM (DI) during the time to intercept, which is the exact distance it should have traveled at 20 K during 1^h 19^m.

2. The distance, 160 NM, between plane

and ship at the initial time (1000), represented by the line CD, is the *distance to close* during interception. At the end of one hour, the remaining distance to close is the line FD', 39 NM in length. The difference between the initial distance to close and the distance to close at the end of one hour represents the distance closed in one hour or the rate of closure. The distance to close at the time of beginning interception divided by rate of closure should give the time to inter-

CHECKS...

1

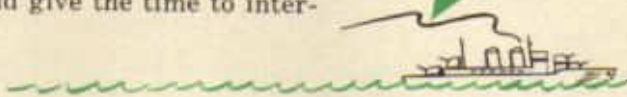

$$\frac{\text{DISTANCE TARGET TRAVELS}}{\text{SPEED}} = \text{TIME TO INTERCEPT}$$

2

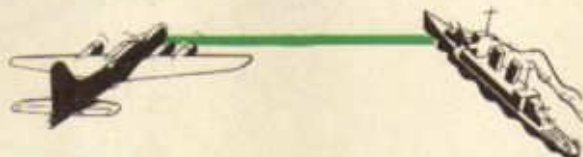

$$\frac{\text{DISTANCE TO CLOSE}}{\text{RATE OF CLOSURE}} = \text{TIME TO INTERCEPT}$$

cept if the diagram has been drawn correctly and the distances accurately measured. In the diagram the rate of closure is 121-K, which, when combined with the distance to close, gives 1^h 19^m, the time to intercept.

Time is saved in drawing the interception diagram if it is drawn on the Mercator chart used by the navigator to carry on his DR plot, rather than on a separate plotting

chart. However, since the scale of the Mercator is not constant, the student should be cautioned to use in his measurements the mid-latitude scale of each line it is desired to measure.

No complications arise when the interception occurs in less than one hour. In the diagram, the plane is on course to intercept the vessel at I. Attention should be drawn to the method of determining the rate of closure in this diagram. F represents the one hour posi-

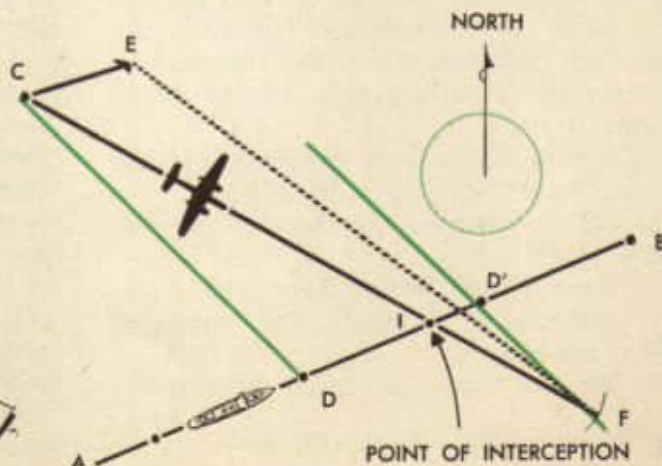
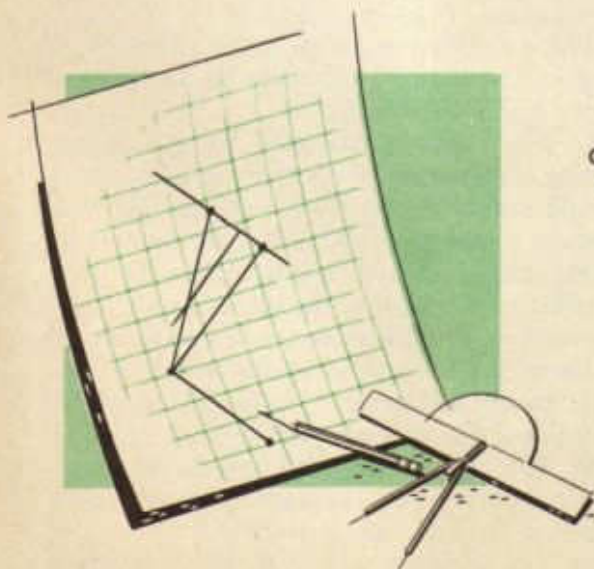

tion of the plane; thus the distance closed in one hour or, in other words, the rate of closure, is represented by the distance to close, CD plus the distance D'F. The time to intercept is determined as before by dividing the distance to close by the rate of closure.

Sometimes the situation may arise where it is known that the target will alter course while interception is taking place. For example, a vessel departs from A at 0000 on a course of 090 at a speed of 30 K. It is known that the ship will alter course to 200 at 0200. Interception is to begin at 0100 from B. The interceptor can maintain a TAS of 100 K and the wind velocity is 090/20 K. The problem is to determine how to draw in the first line of constant bearing, which, as shown before, must extend between the simultaneous positions of plane and ship. But, in this case, if the line were drawn between the actual 0100 positions, the completed diagram would give a course to intercept which would miss the altered course of the ship altogether.

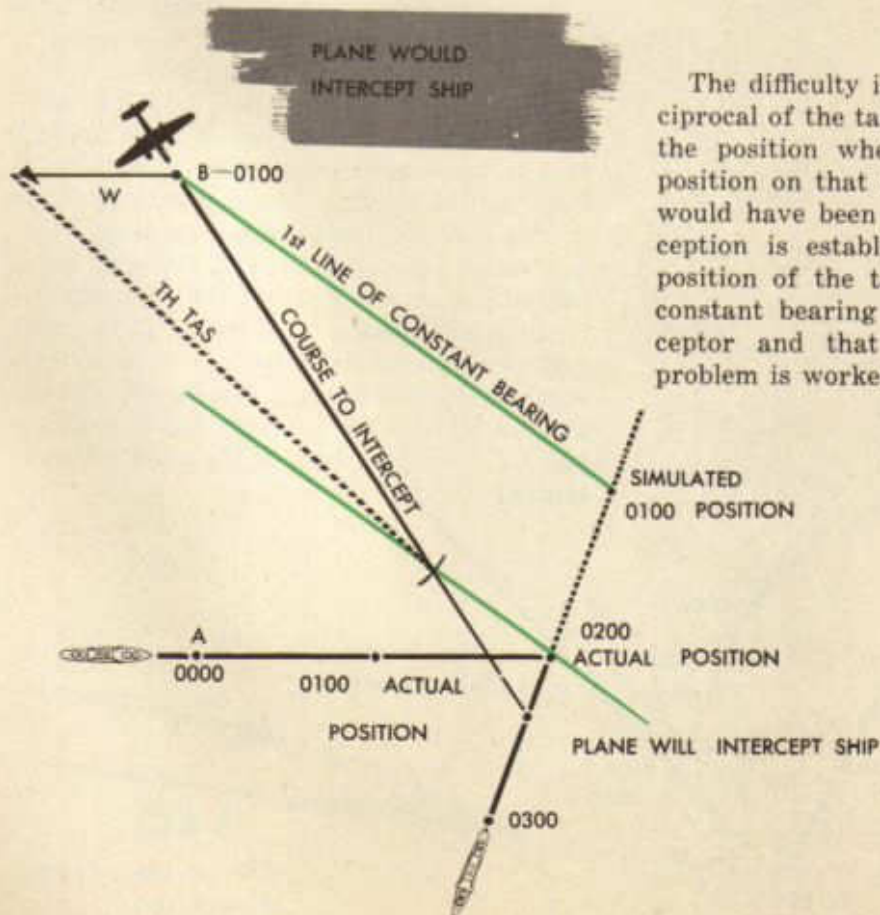
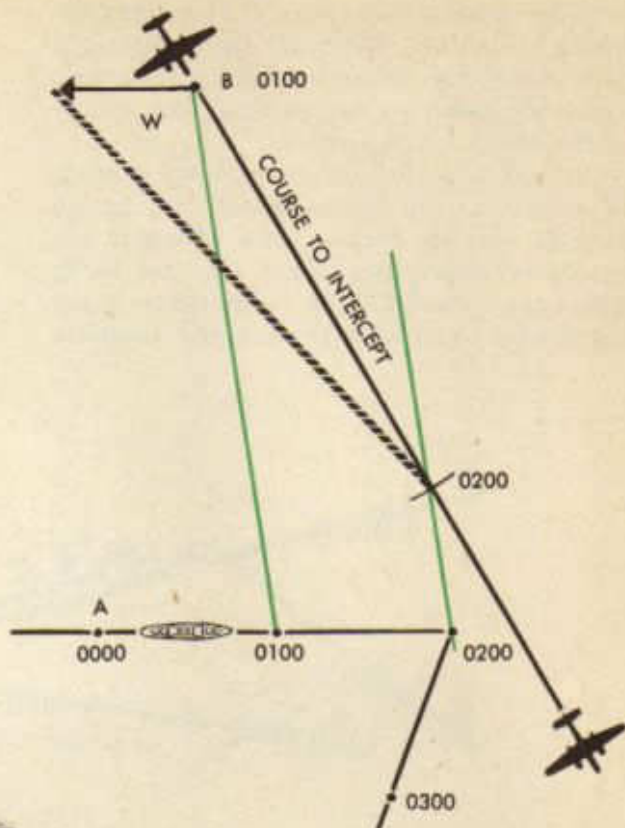

The difficulty is solved by extending a reciprocal of the target's latest course through the position where it altered course. The position on that course at which the target would have been at the beginning of interception is established as the simultaneous position of the target and the first line of constant bearing drawn between the interceptor and that position. Thereafter the problem is worked as before.

If the vessel alters course during interception without the interceptor being informed beforehand, the problem must be reworked, using the latest known position and course of the vessel.

In most interceptions, no attempt is made to determine the course which will arrive directly over the target, since, owing to unavoidable errors, the target may not be in sight when the ETA for interception is up. Erroneous reports of the target's position,

mistaken estimates of its course and speed, and navigational errors by the interceptor itself make exact interception almost impossible. In such cases it is essential that the interceptor know in which direction to turn to locate the target when the target's course has been intercepted. Therefore, in tactical problems the interceptor allows for error by setting a course which will intercept the predicted course of the target at a point either definitely ahead or behind the target itself. The former case is called "leading the target," and when interception occurs behind the target the term "lag" is applied. Whether lead or lag is applied depends upon which will give the shortest distance to intercept.



In the diagram, a vessel has departed from A at 0000 on a course of 030 at a speed of 30 K. The interceptor, whose TAS is 150 K, begins interception from B at 0000. The wind is 200°/20 K. A 25-mile lag is to be applied, that is, interception will occur at a point 25 miles behind the ship. The course to intercept at this point will maintain a constant bearing with a point that is at all times 25 miles behind the ship. Therefore the simultaneous position of the ship is placed at C, 25 miles behind its actual 0000 position, on the reciprocal of the ship's track. Interception occurs at I, at which time the ship has traveled to point J, 25 miles ahead of the point of interception.

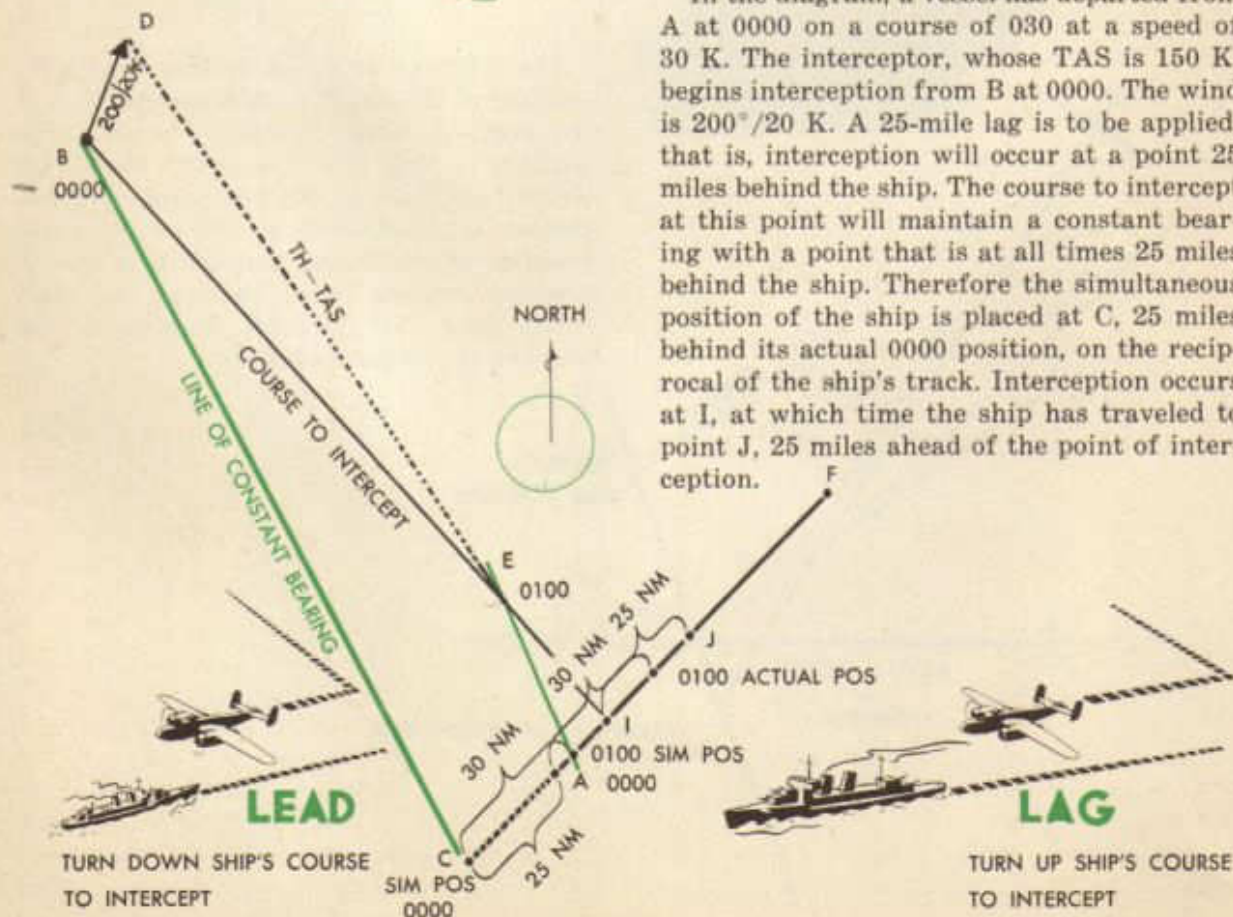

When the interceptor arrives at I, the navigator turns on a course of 030 to search for the ship.

While on course to intercept the navigator should constantly check the groundspeed being maintained. In cases where the wind changes, it may be possible to work controlled groundspeed in order to make good the ETA of interception. However, if the plane cannot maintain the requisite TAS, it may become necessary to rework the interception diagram from a DR position on the course to intercept.

NAVIGATOR'S LOG

PILOT *1st Lt R. Vuesbaum*
 NAVIGATOR *1st Lt Mike Nugent*
 MISSION NO. *Patrol*

DEPARTURE *29°42'N
29°50'W*
 DESTINATION *29°42'N
29°50'W*
 DATE *7/25/44*
 PLANE NO. *B-17 62-1436*

POSITION	TIME	CRS	DRIFT	WIND	WAS	WHD	DEV	COMP	TEMP	ALT	GS	TH	RUN	TO RUN	ETA	ETA
													TIME	DIST		DIST
<i>DR</i>	<i>1650</i>	<i>180</i>	<i>0</i>	<i>180</i>	<i>10E</i>	<i>170</i>	<i>-2</i>	<i>188</i>	<i>81</i>	<i>500</i>	<i>—</i>	<i>—</i>	<i>—</i>	<i>—</i>	<i>—</i>	<i>—</i>
	<i>1655</i>	<i>180</i>	<i>0</i>	<i>180</i>	<i>10E</i>	<i>170</i>	<i>-2</i>	<i>168</i>	<i>18</i>	<i>450</i>	<i>200</i>	<i>at</i>	<i>1715</i>	<i>—</i>	<i>—</i>	<i>—</i>
	<i>1705</i>	<i>180</i>	<i>0</i>	<i>180</i>	<i>10E</i>	<i>170</i>	<i>-2</i>	<i>168</i>	<i>18</i>	<i>450</i>	<i>200</i>	<i>at</i>	<i>1700</i>	<i>—</i>	<i>—</i>	<i>—</i>
	<i>1720</i>	<i>180</i>	<i>0</i>	<i>180</i>	<i>10E</i>	<i>170</i>	<i>-2</i>	<i>168</i>	<i>18</i>	<i>450</i>	<i>200</i>	<i>at</i>	<i>1700</i>	<i>—</i>	<i>—</i>	<i>—</i>
	<i>1730</i>	<i>180</i>	<i>0</i>	<i>180</i>	<i>10E</i>	<i>170</i>	<i>-2</i>	<i>168</i>	<i>18</i>	<i>450</i>	<i>200</i>	<i>at</i>	<i>1700</i>	<i>—</i>	<i>—</i>	<i>—</i>
	<i>1740</i>	<i>180</i>	<i>0</i>	<i>180</i>	<i>10E</i>	<i>170</i>	<i>-2</i>	<i>168</i>	<i>18</i>	<i>450</i>	<i>200</i>	<i>at</i>	<i>1700</i>	<i>—</i>	<i>—</i>	<i>—</i>
	<i>1750</i>	<i>180</i>	<i>0</i>	<i>180</i>	<i>10E</i>	<i>170</i>	<i>-2</i>	<i>168</i>	<i>18</i>	<i>450</i>	<i>200</i>	<i>at</i>	<i>1700</i>	<i>—</i>	<i>—</i>	<i>—</i>
	<i>1800</i>	<i>180</i>	<i>0</i>	<i>180</i>	<i>10E</i>	<i>170</i>	<i>-2</i>	<i>168</i>	<i>18</i>	<i>450</i>	<i>200</i>	<i>at</i>	<i>1700</i>	<i>—</i>	<i>—</i>	<i>—</i>
	<i>1810</i>	<i>180</i>	<i>0</i>	<i>180</i>	<i>10E</i>	<i>170</i>	<i>-2</i>	<i>168</i>	<i>18</i>	<i>450</i>	<i>200</i>	<i>at</i>	<i>1700</i>	<i>—</i>	<i>—</i>	<i>—</i>
	<i>1820</i>	<i>180</i>	<i>0</i>	<i>180</i>	<i>10E</i>	<i>170</i>	<i>-2</i>	<i>168</i>	<i>18</i>	<i>450</i>	<i>200</i>	<i>at</i>	<i>1700</i>	<i>—</i>	<i>—</i>	<i>—</i>
	<i>1830</i>	<i>180</i>	<i>0</i>	<i>180</i>	<i>10E</i>	<i>170</i>	<i>-2</i>	<i>168</i>	<i>18</i>	<i>450</i>	<i>200</i>	<i>at</i>	<i>1700</i>	<i>—</i>	<i>—</i>	<i>—</i>
	<i>1840</i>	<i>180</i>	<i>0</i>	<i>180</i>	<i>10E</i>	<i>170</i>	<i>-2</i>	<i>168</i>	<i>18</i>	<i>450</i>	<i>200</i>	<i>at</i>	<i>1700</i>	<i>—</i>	<i>—</i>	<i>—</i>
	<i>1850</i>	<i>180</i>	<i>0</i>	<i>180</i>	<i>10E</i>	<i>170</i>	<i>-2</i>	<i>168</i>	<i>18</i>	<i>450</i>	<i>200</i>	<i>at</i>	<i>1700</i>	<i>—</i>	<i>—</i>	<i>—</i>
	<i>1900</i>	<i>180</i>	<i>0</i>	<i>180</i>	<i>10E</i>	<i>170</i>	<i>-2</i>	<i>168</i>	<i>18</i>	<i>450</i>	<i>200</i>	<i>at</i>	<i>1700</i>	<i>—</i>	<i>—</i>	<i>—</i>
	<i>1910</i>	<i>180</i>	<i>0</i>	<i>180</i>	<i>10E</i>	<i>170</i>	<i>-2</i>	<i>168</i>	<i>18</i>	<i>450</i>	<i>200</i>	<i>at</i>	<i>1700</i>	<i>—</i>	<i>—</i>	<i>—</i>
	<i>1920</i>	<i>180</i>	<i>0</i>	<i>180</i>	<i>10E</i>	<i>170</i>	<i>-2</i>	<i>168</i>	<i>18</i>	<i>450</i>	<i>200</i>	<i>at</i>	<i>1700</i>	<i>—</i>	<i>—</i>	<i>—</i>
	<i>1930</i>	<i>180</i>	<i>0</i>	<i>180</i>	<i>10E</i>	<i>170</i>	<i>-2</i>	<i>168</i>	<i>18</i>	<i>450</i>	<i>200</i>	<i>at</i>	<i>1700</i>	<i>—</i>	<i>—</i>	<i>—</i>
	<i>1940</i>	<i>180</i>	<i>0</i>	<i>180</i>	<i>10E</i>	<i>170</i>	<i>-2</i>	<i>168</i>	<i>18</i>	<i>450</i>	<i>200</i>	<i>at</i>	<i>1700</i>	<i>—</i>	<i>—</i>	<i>—</i>
	<i>1950</i>	<i>180</i>	<i>0</i>	<i>180</i>	<i>10E</i>	<i>170</i>	<i>-2</i>	<i>168</i>	<i>18</i>	<i>450</i>	<i>200</i>	<i>at</i>	<i>1700</i>	<i>—</i>	<i>—</i>	<i>—</i>
	<i>2000</i>	<i>180</i>	<i>0</i>	<i>180</i>	<i>10E</i>	<i>170</i>	<i>-2</i>	<i>168</i>	<i>18</i>	<i>450</i>	<i>200</i>	<i>at</i>	<i>1700</i>	<i>—</i>	<i>—</i>	<i>—</i>
	<i>2010</i>	<i>180</i>	<i>0</i>	<i>180</i>	<i>10E</i>	<i>170</i>	<i>-2</i>	<i>168</i>	<i>18</i>	<i>450</i>	<i>200</i>	<i>at</i>	<i>1700</i>	<i>—</i>	<i>—</i>	<i>—</i>
	<i>2020</i>	<i>180</i>	<i>0</i>	<i>180</i>	<i>10E</i>	<i>170</i>	<i>-2</i>	<i>168</i>	<i>18</i>	<i>450</i>	<i>200</i>	<i>at</i>	<i>1700</i>	<i>—</i>	<i>—</i>	<i>—</i>
	<i>2030</i>	<i>180</i>	<i>0</i>	<i>180</i>	<i>10E</i>	<i>170</i>	<i>-2</i>	<i>168</i>	<i>18</i>	<i>450</i>	<i>200</i>	<i>at</i>	<i>1700</i>	<i>—</i>	<i>—</i>	<i>—</i>
	<i>2040</i>	<i>180</i>	<i>0</i>	<i>180</i>	<i>10E</i>	<i>170</i>	<i>-2</i>	<i>168</i>	<i>18</i>	<i>450</i>	<i>200</i>	<i>at</i>	<i>1700</i>	<i>—</i>	<i>—</i>	<i>—</i>
	<i>2050</i>	<i>180</i>	<i>0</i>	<i>180</i>	<i>10E</i>	<i>170</i>	<i>-2</i>	<i>168</i>	<i>18</i>	<i>450</i>	<i>200</i>	<i>at</i>	<i>1700</i>	<i>—</i>	<i>—</i>	<i>—</i>
	<i>2100</i>	<i>180</i>	<i>0</i>	<i>180</i>	<i>10E</i>	<i>170</i>	<i>-2</i>	<i>168</i>	<i>18</i>	<i>450</i>	<i>200</i>	<i>at</i>	<i>1700</i>	<i>—</i>	<i>—</i>	<i>—</i>
	<i>2110</i>	<i>180</i>	<i>0</i>	<i>180</i>	<i>10E</i>	<i>170</i>	<i>-2</i>	<i>168</i>	<i>18</i>	<i>450</i>	<i>200</i>	<i>at</i>	<i>1700</i>	<i>—</i>	<i>—</i>	<i>—</i>
	<i>2120</i>	<i>180</i>	<i>0</i>	<i>180</i>	<i>10E</i>	<i>170</i>	<i>-2</i>	<i>168</i>	<i>18</i>	<i>450</i>	<i>200</i>	<i>at</i>	<i>1700</i>	<i>—</i>	<i>—</i>	<i>—</i>
	<i>2130</i>	<i>180</i>	<i>0</i>	<i>180</i>	<i>10E</i>	<i>170</i>	<i>-2</i>	<i>168</i>	<i>18</i>	<i>450</i>	<i>200</i>	<i>at</i>	<i>1700</i>	<i>—</i>	<i>—</i>	<i>—</i>
	<i>2140</i>	<i>180</i>	<i>0</i>	<i>180</i>	<i>10E</i>	<i>170</i>	<i>-2</i>	<i>168</i>	<i>18</i>	<i>450</i>	<i>200</i>	<i>at</i>	<i>1700</i>	<i>—</i>	<i>—</i>	<i>—</i>
	<i>2150</i>	<i>180</i>	<i>0</i>	<i>180</i>	<i>10E</i>	<i>170</i>	<i>-2</i>	<i>168</i>	<i>18</i>	<i>450</i>	<i>200</i>	<i>at</i>	<i>1700</i>	<i>—</i>	<i>—</i>	<i>—</i>
	<i>2200</i>	<i>180</i>	<i>0</i>	<i>180</i>	<i>10E</i>	<i>170</i>	<i>-2</i>	<i>168</i>	<i>18</i>	<i>450</i>	<i>200</i>	<i>at</i>	<i>1700</i>	<i>—</i>	<i>—</i>	<i>—</i>
	<i>2210</i>	<i>180</i>	<i>0</i>	<i>180</i>	<i>10E</i>	<i>170</i>	<i>-2</i>	<i>168</i>	<i>18</i>	<i>450</i>	<i>200</i>	<i>at</i>	<i>1700</i>	<i>—</i>	<i>—</i>	<i>—</i>
	<i>2220</i>	<i>180</i>	<i>0</i>	<i>180</i>	<i>10E</i>	<i>170</i>	<i>-2</i>	<i>168</i>	<i>18</i>	<i>450</i>	<i>200</i>	<i>at</i>	<i>1700</i>	<i>—</i>	<i>—</i>	<i>—</i>
	<i>2230</i>	<i>180</i>	<i>0</i>	<i>180</i>	<i>10E</i>	<i>170</i>	<i>-2</i>	<i>168</i>	<i>18</i>	<i>450</i>	<i>200</i>	<i>at</i>	<i>1700</i>	<i>—</i>	<i>—</i>	<i>—</i>
	<i>2240</i>	<i>180</i>	<i>0</i>	<i>180</i>	<i>10E</i>	<i>170</i>	<i>-2</i>	<i>168</i>	<i>18</i>	<i>450</i>	<i>200</i>	<i>at</i>	<i>1700</i>	<i>—</i>	<i>—</i>	<i>—</i>
	<i>2250</i>	<i>180</i>	<i>0</i>	<i>180</i>	<i>10E</i>	<i>170</i>	<i>-2</i>	<i>168</i>	<i>18</i>	<i>450</i>	<i>200</i>	<i>at</i>	<i>1700</i>	<i>—</i>	<i>—</i>	<i>—</i>
	<i>2300</i>	<i>180</i>	<i>0</i>	<i>180</i>	<i>10E</i>	<i>170</i>	<i>-2</i>	<i>168</i>	<i>18</i>	<i>450</i>	<i>200</i>	<i>at</i>	<i>1700</i>	<i>—</i>	<i>—</i>	<i>—</i>
	<i>2310</i>	<i>180</i>	<i>0</i>	<i>180</i>	<i>10E</i>	<i>170</i>	<i>-2</i>	<i>168</i>	<i>18</i>	<i>450</i>	<i>200</i>	<i>at</i>	<i>1700</i>	<i>—</i>	<i>—</i>	<i>—</i>
	<i>2320</i>	<i>180</i>	<i>0</i>	<i>180</i>	<i>10E</i>	<i>170</i>	<i>-2</i>	<i>168</i>	<i>18</i>	<i>450</i>	<i>200</i>	<i>at</i>	<i>1700</i>	<i>—</i>	<i>—</i>	<i>—</i>
	<i>2330</i>	<i>180</i>	<i>0</i>	<i>180</i>	<i>10E</i>	<i>170</i>	<i>-2</i>	<i>168</i>	<i>18</i>	<i>450</i>	<i>200</i>	<i>at</i>	<i>1700</i>	<i>—</i>	<i>—</i>	<i>—</i>
	<i>2340</i>	<i>180</i>	<i>0</i>	<i>180</i>	<i>10E</i>	<i>170</i>	<i>-2</i>	<i>168</i>	<i>18</i>	<i>450</i>	<i>200</i>	<i>at</i>	<i>1700</i>	<i>—</i>	<i>—</i>	<i>—</i>
	<i>2350</i>	<i>180</i>	<i>0</i>	<i>180</i>	<i>10E</i>	<i>170</i>	<i>-2</i>	<i>168</i>	<i>18</i>	<i>450</i>	<i>200</i>	<i>at</i>	<i>1700</i>	<i>—</i>	<i>—</i>	<i>—</i>
	<i>2400</i>	<i>180</i>	<i>0</i>	<i>180</i>	<i>10E</i>	<i>170</i>	<i>-2</i>	<i>168</i>	<i>18</i>	<i>450</i>	<i>200</i>	<i>at</i>	<i>1700</i>	<i>—</i>	<i>—</i>	<i>—</i>
	<i>2410</i>	<i>180</i>	<i>0</i>	<i>180</i>	<i>10E</i>	<i>170</i>	<i>-2</i>	<i>168</i>	<i>18</i>	<i>450</i>	<i>200</i>	<i>at</i>	<i>1700</i>	<i>—</i>	<i>—</i>	<i>—</i>
	<i>2420</i>	<i>180</i>	<i>0</i>	<i>180</i>	<i>10E</i>	<i>170</i>	<i>-2</i>	<i>168</i>	<i>18</i>	<i>450</i>	<i>200</i>	<i>at</i>	<i>1700</i>	<i>—</i>	<i>—</i>	<i>—</i>
	<i>2430</i>	<i>180</i>	<i>0</i>	<i>180</i>	<i>10E</i>	<i>170</i>	<i>-2</i>	<i>168</i>	<i>18</i>	<i>450</i>	<i>200</i>	<i>at</i>	<i>1700</i>	<i>—</i>	<i>—</i>	<i>—</i>
	<i>2440</i>	<i>180</i>	<i>0</i>	<i>180</i>	<i>10E</i>	<i>170</i>	<i>-2</i>	<i>168</i>	<i>18</i>	<i>450</i>	<i>200</i>	<i>at</i>	<i>1700</i>	<i>—</i>	<i>—</i>	<i>—</i>
	<i>2450</i>	<i>180</i>	<i>0</i>	<i>180</i>	<i>10E</i>	<i>170</i>	<i>-2</i>	<i>168</i>	<i>18</i>	<i>450</i>	<i>200</i>	<i>at</i>	<i>1700</i>	<i>—</i>	<i>—</i>	<i>—</i>
	<i>2500</i>	<i>180</i>	<i>0</i>	<i>180</i>	<i>10E</i>	<i>170</i>	<i>-2</i>	<i>168</i>	<i>18</i>	<i>450</i>	<i>200</i>	<i>at</i>	<i>1700</i>	<i>—</i>	<i>—</i>	<i>—</i>
	<i>2510</i>	<i>180</i>	<i>0</i>	<i>180</i>	<i>10E</i>	<i>170</i>	<i>-2</i>	<i>168</i>	<i>18</i>	<i>450</i>	<i>200</i>	<i>at</i>	<i>1700</i>	<i>—</i>	<i>—</i>	<i>—</i>
	<i>2520</i>	<i>180</i>	<i>0</i>	<i>180</i>	<i>10E</i>	<i>170</i>	<i>-2</i>	<i>168</i>	<i>18</i>	<i>450</i>	<i>200</i>	<i>at</i>	<i>1700</i>	<i>—</i>	<i>—</i>	<i>—</i>
	<i>2530</i>	<i>180</i>	<i>0</i>	<i>180</i>	<i>10E</i>	<i>170</i>	<i>-2</i>	<i>168</i>	<i>18</i>	<i>450</i>	<i>200</i>	<i>at</i>	<i>1700</i>	<i>—</i>	<i>—</i>	<i>—</i>
	<i>2540</i>	<i>180</i>	<i>0</i>	<i>180</i>	<i>10E</i>	<i>170</i>	<i>-2</i>	<i>168</i>	<i>18</i>	<i>450</i>	<i>200</i>	<i>at</i>	<i>1700</i>	<i>—</i>	<i>—</i>	<i>—</i>
	<i>2550</i>	<i>180</i>	<i>0</i>	<i>180</i>	<i>10E</i>	<i>170</i>	<i>-2</i>	<i>168</i>	<i>18</i>	<i>450</i>	<i>200</i>	<i>at</i>	<i>1700</i>	<i>—</i>	<i>—</i>	<i>—</i>
	<i>2600</i>	<i>180</i>	<i>0</i>	<i>180</i>	<i>10E</i>	<i>170</i>	<i>-2</i>	<i>168</i>	<i>18</i>	<i>450</i>	<i>200</i>	<i>at</i>	<i>1700</i>	<i>—</i>	<i>—</i>	<i>—</i>
	<i>2610</i>	<i>180</i>	<i>0</i>	<i>180</i> </												

INTERCEPTION ON E-6B COMPUTER

There are two varying factors that influence the heading of an aircraft in an interception flight: (1) the wind direction and velocity, and (2) the vessel's course and speed. These two factors are combined into a single resultant vector in order to determine the true heading to intercept. The rate of closure is also a result of the two varying factors and is indicated at the end of the

resultant arrow when the final setting is found. The remainder of the vector problem is solved in the usual manner.

Before the computer can be used, the bearing and distance of the vessel from the intercepting aircraft must be determined. This method of working an interception is used only in the interception of surface craft, since the vessel's speed must be plotted within the limits of the computer face.

Problem:

At 0900 the vessel is at $36^{\circ}30'N-98^{\circ}00'W$ on a true course of 150° at 34 knots.

Your base is at $37^{\circ}47'N-94^{\circ}28'W$.

Wind: $290^{\circ}/22$ knots. TAS 160 knots.

Begin interception at 1000, allowing a 25 nautical mile positive lead.

1000 lead position of ship bears 228° and 190 nautical miles from your base.

Required:

TH (223°)

TC ($215\frac{1}{2}^{\circ}$)

GS (153 knots)

Rate of closure (142 knots)

Time of Interception (1120)

Position of Interception ($35^{\circ}00'N-96^{\circ}55'W$)

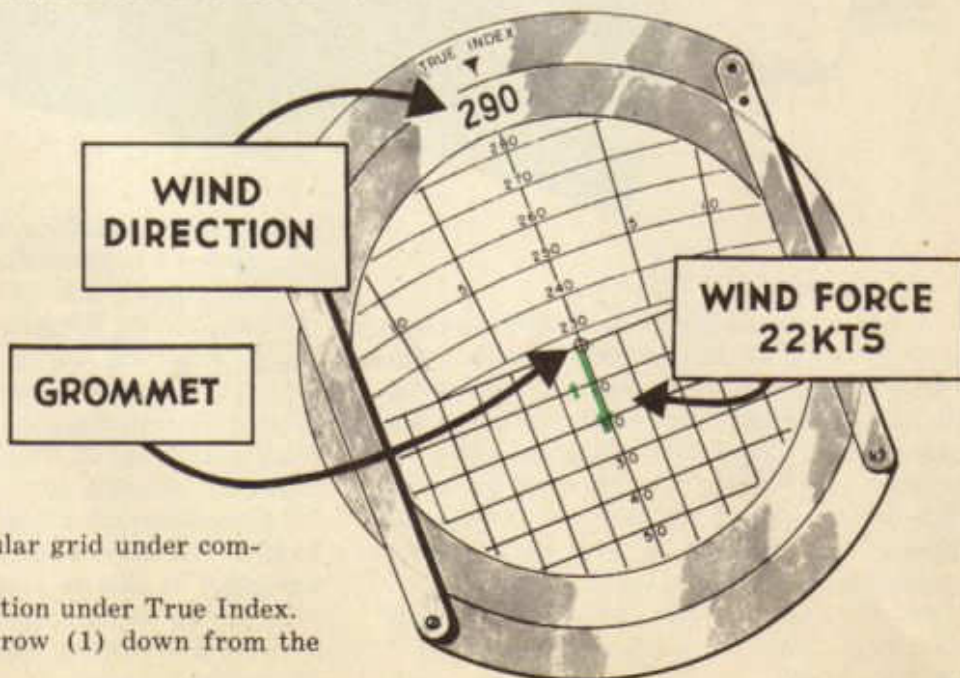

1. Place rectangular grid under computer face.
2. Set wind direction under True Index.
3. Draw wind arrow (1) down from the grommet.

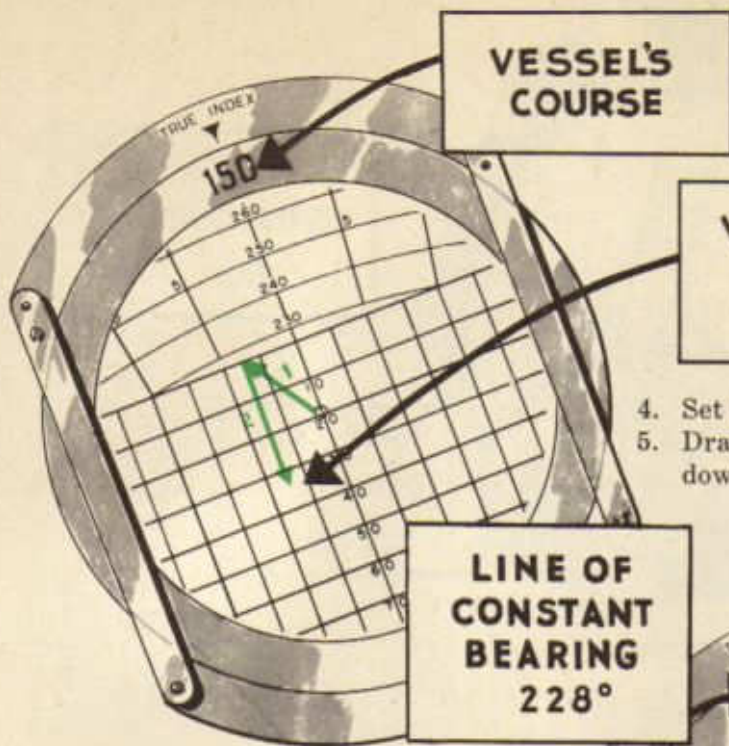

**VESSEL'S
SPEED
34 KTS**

4. Set vessel's course under True Index.
5. Draw arrow for vessel's speed (2) down from head of the wind arrow.

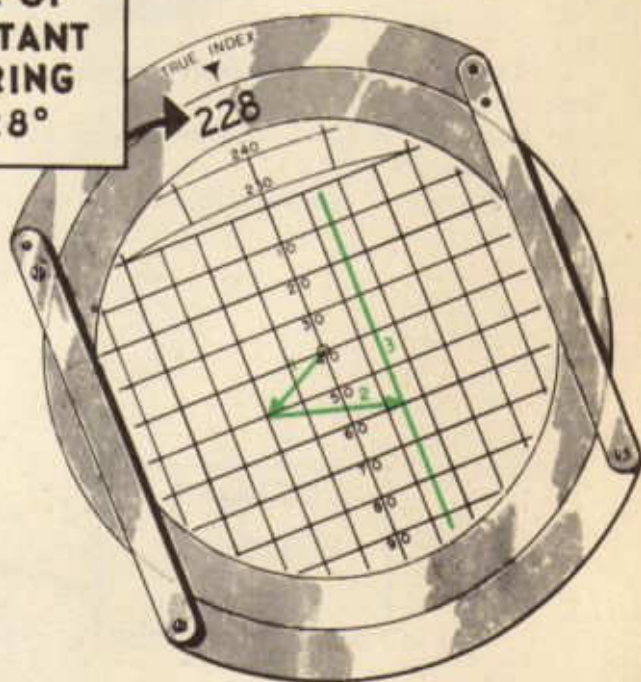

6. Set direction of line of constant bearing under True Index.
7. Draw vertical line (3) paralleling grid lines at head of vessel's arrow.

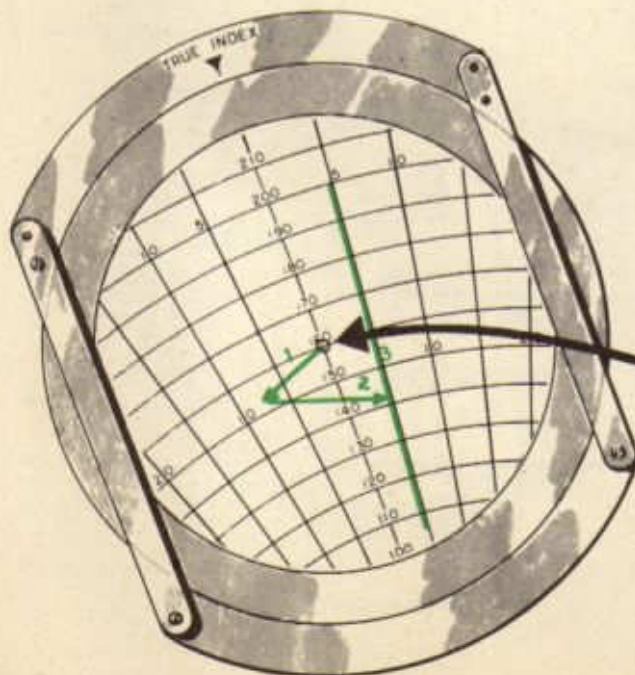

**TAS
160 KTS**

8. Place circular grid under computer face.
9. Place TAS under grommet.
10. Shift computer face until vertical line (3) parallels drift lines on card.

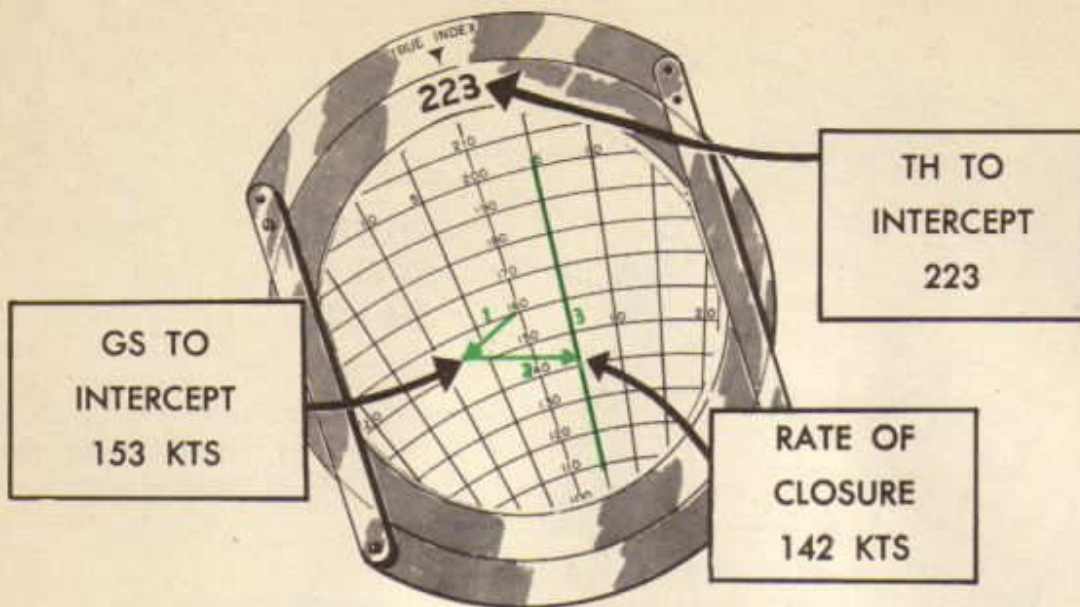

11. Read TH to point of interception under True Index.
12. Read GS to point of interception at head of wind arrow (1).
13. Read rate of closure at head of vessel arrow (2).

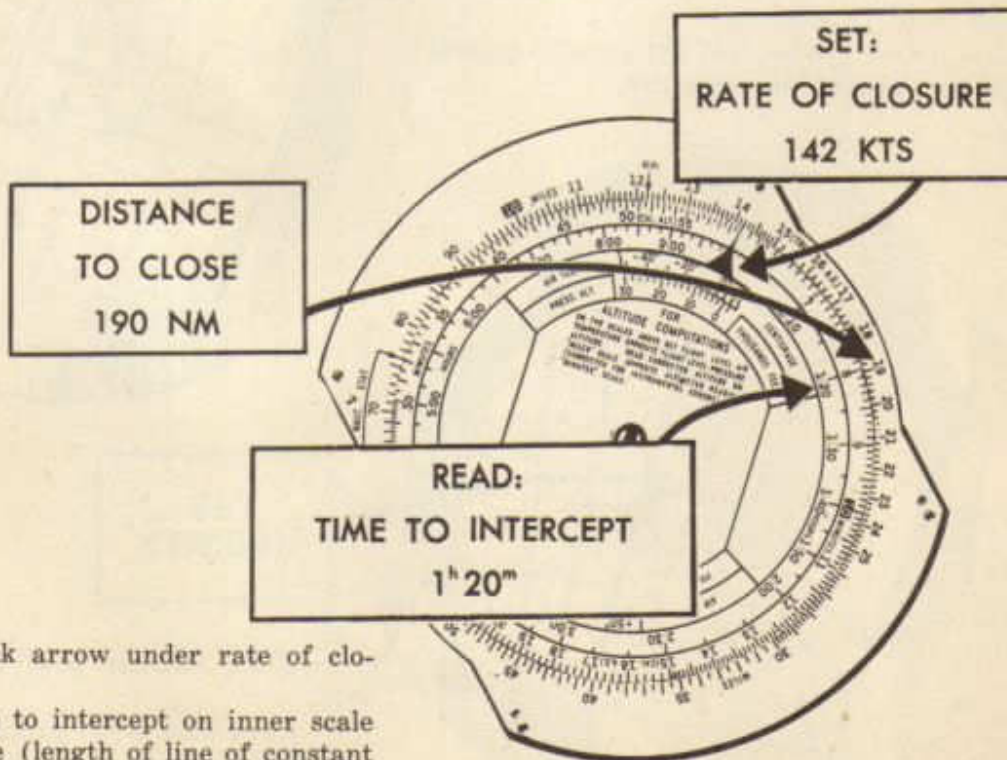

14. Place black arrow under rate of closure.
15. Read time to intercept on inner scale opposite to close (length of line of constant bearing).

Radius of Action to the Same Base

Crew members are constantly working to secure the maximum performance of an aircraft while on tactical duty. When flying on scouting and patrol missions, the navigator must determine how to cover the greatest ground distance in a specified time. One problem of this nature is determination of *Radius of Action*. The radius of action of an aircraft is the greatest ground distance it can fly outward from a given point on a given course before returning to the same or another point within a limited time. In solving this type of problem, the navigator must determine the heading to be flown on the trip out, when and where to make the turn, and the heading to be flown on the return leg.

The radius of action may be plotted or computed before take-off, but once in the air, dead reckoning methods, supplemented by radio and other navigational aids must be used to make good the pre-computed courses and distances.

Various factors enter into the determination of the radius of action of an aircraft.

Each factor, singly or in combination with other factors, is important in determining the distance an aircraft may fly under known conditions. The resultant of certain factors may aid or hinder the aircraft while in flight; therefore, the navigator must have a thorough understanding of the values of each factor, the relation one bears to another, and the correct application of each to the problem under consideration.

There are three basic factors dealt with in working radius of action problems, namely wind, time, and airspeed.

Wind has a pronounced effect on the time required to fly a given distance. For a two-way trip, wind is always a hindrance, unless it changes so that there is a tail wind for both legs. The maximum radius of action results when the wind is at right angles to the course. The minimum radius of action results when the wind is parallel to the course. If the aircraft has been flying with a tail wind and has used half of the gas load, it can never expect to get back to its starting point unless the wind changes.



**R/A CAN BE COMPUTED
BEFORE TAKE-OFF—
THEN CHECKED IN FLIGHT**



Time is affected by the wind, fuel supply, rate of fuel consumption, and fuel safety margin allowance.

A radius of action problem may easily be solved by the use of two wind vector diagrams. These diagrams are used in a manner similar to that explained previously, except that two modifications are introduced.

First the wind is drawn from the point of departure instead of from the end of the true heading and true airspeed vector. Second, the two graphic solutions used are combined into one vector diagram, which is considered the basic diagram for radius of action to the same base.

The two diagrams below picture a plane flying from departure point E, to turning point P, and return. Just prior to departing the navigator had calculated the true airspeed, the true course to be made good, and the prevailing wind speed and direction. In the first diagram the true course was drawn from the departure point in the direction of the turning point. Then the True Airspeed was used to strike an arc from the end of the wind vector and intersecting the true course at the turning point P. The true heading was then drawn and measured from the end of the wind vector W to the turning point P. The groundspeed was then measured from the departure point along the true course to the turning point.

The second diagram is just the reverse of the first and shows the return trip from turning point P to the departure point E. Notice that the turning point P has become the plane's departure point and that the original departure point E has become the destination.

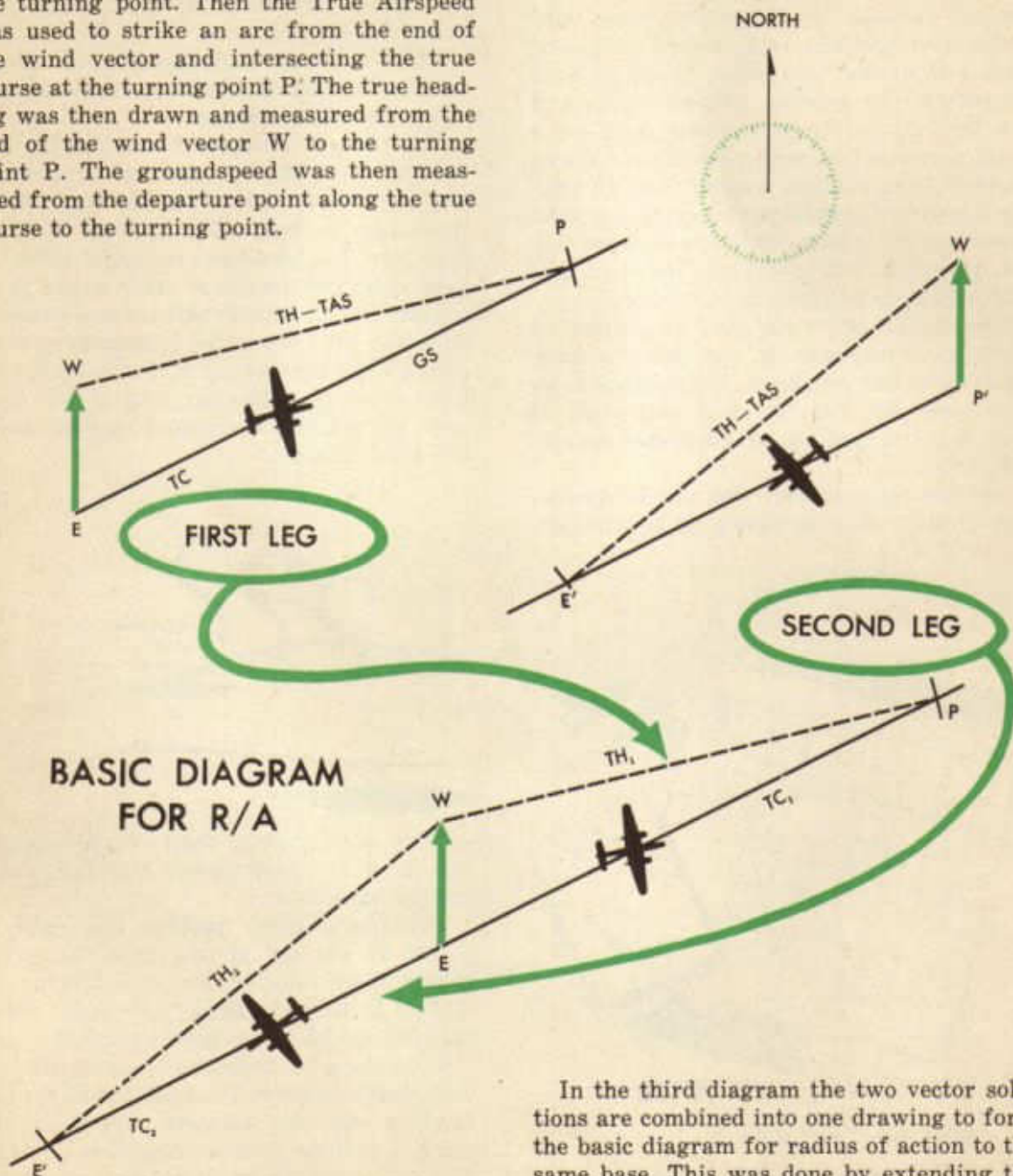

In the third diagram the two vector solutions are combined into one drawing to form the basic diagram for radius of action to the same base. This was done by extending the reciprocal of the true course out beyond the point of departure.

There are definite reasons for drawing the wind from the point of departure. In the first place, the point of departure is always known and the wind force and direction can usually be found.

Also the true airspeed and true course are usually known; therefore, it is a very simple matter to determine the groundspeed by drawing the wind from the point of departure and using the true airspeed to strike an arc on the true course.

Now consider an actual example of radius of action to the same base. The aircraft is ordered to depart at 1200 and to scout a true course of 090 to a maximum distance and return in three hours. A true airspeed of 150 knots is to be maintained with a wind from 320 degrees at 20 knots.

The navigator must calculate the true heading to be flown on both legs and the time to turn at the end of the first leg. The first step is to construct the basic wind vector diagram for radius of action to the same base. It is also necessary to make some distinction between the headings, courses, and speeds. This distinction is made by designating all data pertinent to the trip out as TH_1 , TC_1 , and GS_1 . All data used on the return trip is distinguished by TH_2 , TC_2 , and GS_2 . The wind and the true airspeed remain constant.

The navigator takes the following steps in constructing the basic wind vector diagram for radius of action to the same base. 1. The course (TC_1) is drawn from departure in the direction to be flown on the first leg. 2. The wind vector is drawn downwind from the departure point.

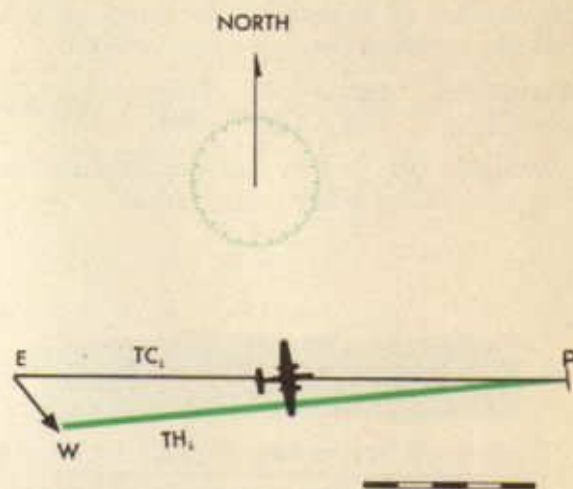

3. The true airspeed (150 knots) is used to strike an arc from the end of the wind vector to the point of intersection with the true course out. 4. The true heading out (TH_1) is measured and found to be 084. 5. The groundspeed out (GS_1) is found to be 162 knots when measured along the TC_1 . 6. The course for the return trip (TC_2) is drawn as the reciprocal of 090 or 270 from the point of departure. 7. The True airspeed (150 knots) is used to strike an arc from the end of the wind vector to the point of intersection with the true course back (TC_2). 8. The true heading back (TH_2) is found to be 276, and the groundspeed back (GS_2) is 136 knots.

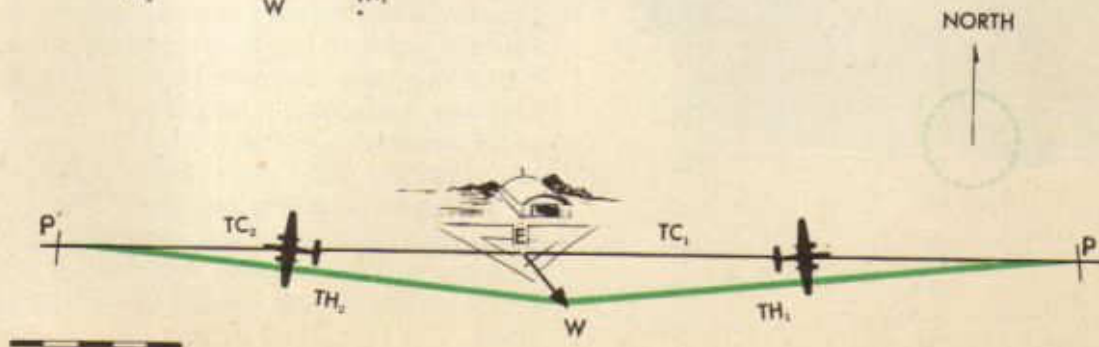
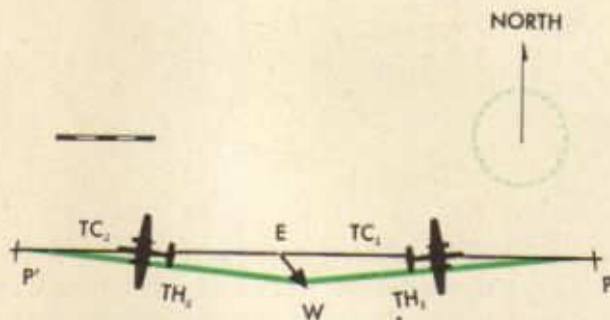

Up to this point the radius of action problem has been merely a wind vector graphic solution to determine headings and ground-speeds. There remains the problem of finding the number of minutes to be flown on the first leg. Knowing the estimated ground-speed for both legs, and the total time allowed for the flight, the navigator can find the number of minutes to be flown on the first leg by using the following formula:

$$\text{Minutes on First Leg} = \frac{180 \times 136}{162 + 136} = \frac{24480}{298} = 82 \text{ min.}$$

Multiply GS₁ × t to obtain R/A distance
R/A = 162 × 1^h22^m = 221 miles.

TIME ON 1ST LEG =

$$\frac{(\text{TOTAL FLT TIME IN MIN}) \times (\text{SPEED OF RETURN})}{(\text{SPEED OF DEPARTURE}) + (\text{SPEED OF RETURN})}$$

$$t = \frac{T \times GS_2}{GS_1 + GS_2}$$

T = TOTAL TIME
MINUS RESERVE

t = TIME ON 1ST LEG

Radius of Action to an Alternate Base

In the preceding section it was found that radius of action to the same base implied the greatest ground distance that an aircraft may travel from a departure base along a given course and still return to the same base in a specified time. Radius of action to an alternate base presents a more difficult problem. The alternate base may be either a moving carrier or a stationary base. In either case it may be thought of as a point moving along a straight line from the departure point to the position of the alternate base. It will be seen that groundspeed ceases to be the rate of departure or return when the base is moving. Thus, in addition to GS, the rate of departure and rate of return must be determined.

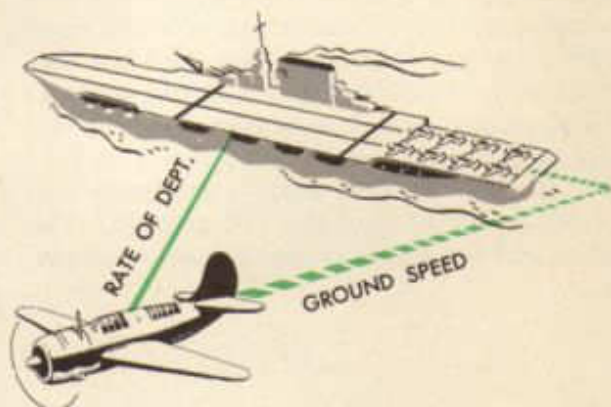

The range of an aircraft is limited by time, fuel, and weather. Completing a mission with the maximum distance covered involves careful calculation of length of flight before turning toward the alternate base. The problem becomes increasingly important when adverse weather conditions make it necessary to change the flight plan during the mission, returning to an emergency base. The ability to calculate accurately and complete the mission as well as possible within the safety limits of fuel supply cannot be over-emphasized.

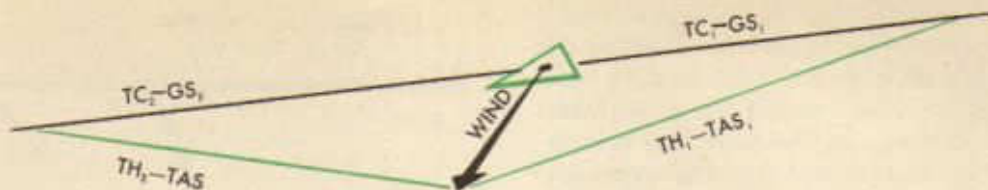

In order to understand better the problem of radius of action to an alternate base, a short review of the simpler problem, radius of action to the same base, should be helpful.

In radius of action to the same base, the groundspeed out (GS_1) is the rate at which the aircraft is leaving the departure point. Upon turning and heading back, the groundspeed back (GS_2) becomes the rate at which it is converging on the departure point. The departure point does not move and the aircraft flies directly away and then returns on a reciprocal course directly toward the base; therefore, the bearing between the aircraft and the departure point remains constant.

On the other hand, in radius of action to an alternate base, the point which the aircraft is leaving and converging on is a moving point; therefore, GS_1 may not be the rate of departure and GS_2 may not be the rate at which the aircraft is converging on this moving point. Below is a diagram showing the location of the moving point at various times.

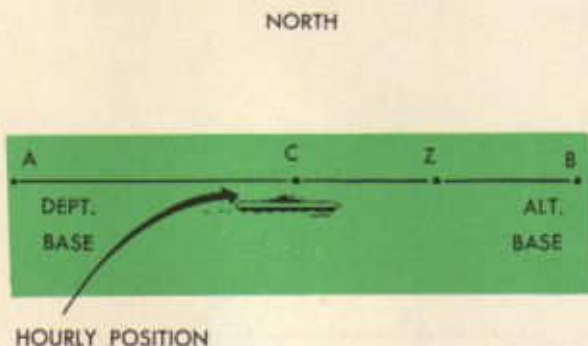

Suppose that the moving point has two hours to get from base A to base B. Then, at an even rate of speed, it will be exactly half way between A and B at the end of one hour. Likewise, after one and a half hours have elapsed, it will be three-fourths of the way (point Z). At the end of two hours this moving point has traced a straight line from A to B. Thus, the total allowable time (T) was two hours; therefore, since the radius of action will be worked on the hourly basis, the moving point will be exactly half way between A and B at the end of one hour or at point C.

An aircraft may be ordered to leave a land base and patrol a certain course and return to a different land base after a given time, or it may be ordered to leave on patrol from a moving base, such as an aircraft carrier, and return to the carrier after a given time. In either case the radius of action problem may be worked in a similar manner.

In order to explain better the moving point concept, take the case of an aircraft which takes off from a carrier and patrols at a uniform speed on a southeast course and then returns to the carrier at a uniform speed on a northeast course at the end of four hours. The carrier continues at a uniform speed on a course of due East between the time of take off and return of the aircraft. A no-wind condition is assumed.

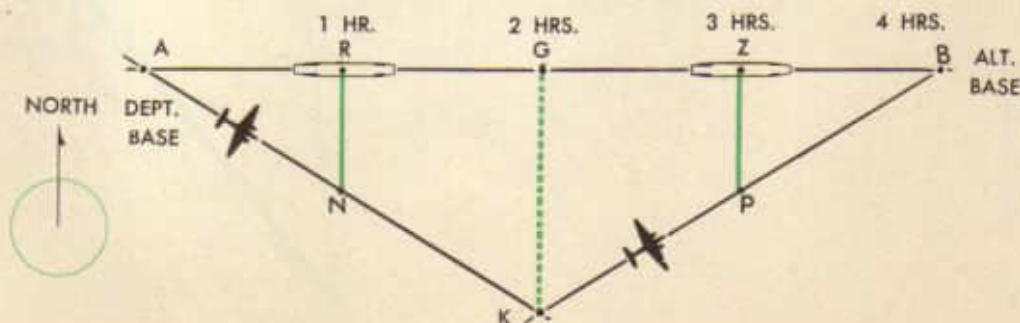

The carrier and the aircraft will move apart at a uniform rate and the bearing of a line joining them at any time will be constant provided each maintains a uniform course and distance. In one hour this rate of departure is represented by the constant bearing line RN . At the end of two hours the length of this constant bearing line has been doubled and appears as line GK in the diagram. At this time the aircraft changes course and begins flying toward the carrier. On the return trip the aircraft and the carrier will move toward each other at a constant rate if each maintains a uniform course and speed. This is called the rate of closure and is represented by the constant bearing line ZP which joins the aircraft and carrier at the end of three hours.

In this case the rate of closure ZP is equal to the rate of departure RN , only because the aircraft is not being affected by a wind. In four hours the aircraft should return to the carrier at the point B .

The radius of action to an alternate base can be solved by using a wind vector diagram similar in appearance and construction to the basic diagram used for R/A to the same base. However, it is necessary to introduce several variations in solving R/A to an alternate base. One difference is the use of a constant bearing line to join the aircraft's position and the position of the moving base at exactly one hour after departure time. Also

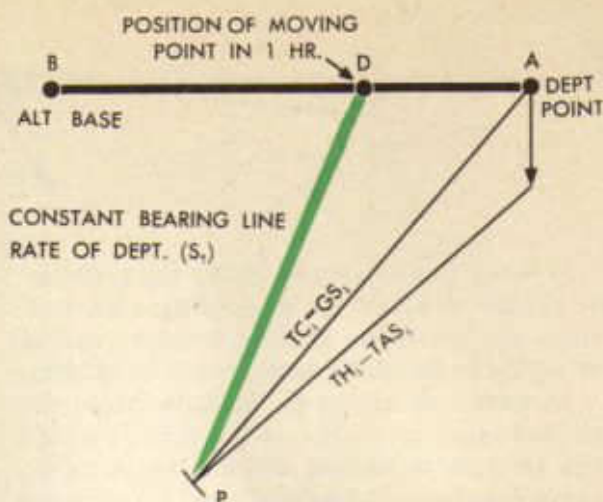

instead of drawing TC_2 as the reciprocal of TC_1 , as is the case in solving R/A to the same base, a different procedure is used. TC_2 is drawn from the departure base to a point where it intersects the constant bearing line projected through and beyond the moving point's hourly position. However, before TC_2 can be drawn, its point of intersection with the extended constant bearing line must be located. This point is located by using the TAS , to scale, to swing an arc from the end of the wind vector and intersecting the extended constant bearing line.

The solution of an actual problem of R/A to an alternate base is shown in the diagram below.

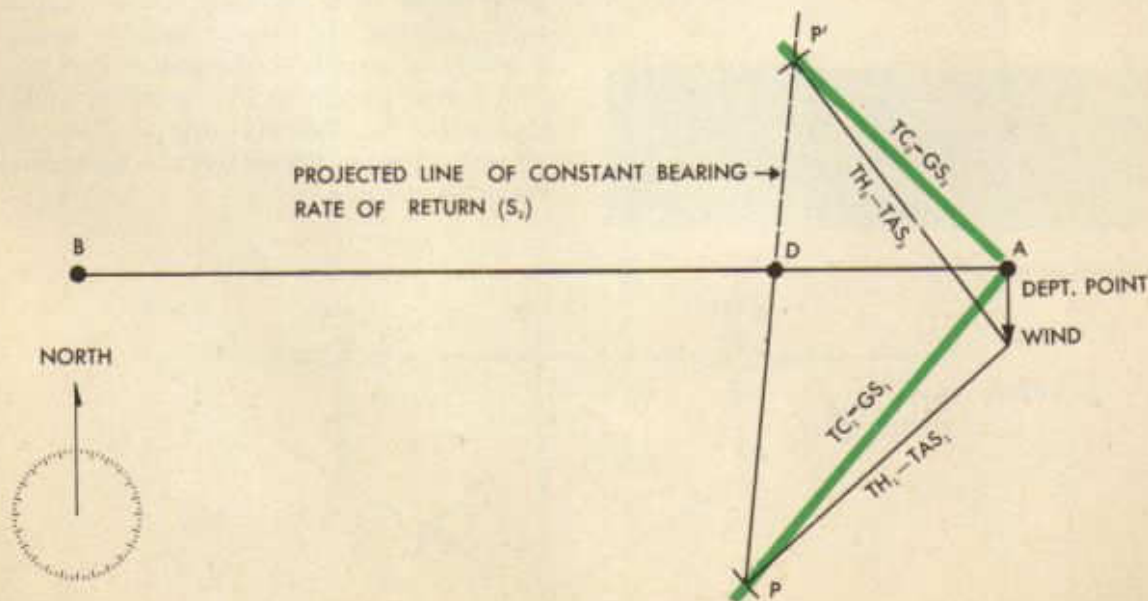

An aircraft with a true airspeed of 140 knots was ordered to patrol a true course of 220 from departure base A and return within four hours to an alternate base B, which is 300 nautical miles on a bearing of 270 from departure base A. The wind is from 000 degrees at 25 knots.

The navigator must find the true headings to be flown on the courses out and back, and when and where to make the turn to come back.

Upon taking off to patrol course AP, the departure base A is imagined to begin moving at a uniform rate on a straight line toward the alternate base B. Since the total allowable time is four hours, the moving base will be at the alternate position B at the end of that time. If the R/A is worked correctly, the aircraft will be at alternate base B when T, the total allowable time, is used up. Then the navigator must determine the R/A in order to get the turning point and direction of the true course back (TC₂) to the alternate base's T position, B. The effect of the wind on the plane must be considered; therefore, the wind is drawn in from the departure point A just as in R/A to the same base. From the end of the wind vector W the TAS, which is constant, is measured to P where it cuts the true course out (TC₁). Now the navigator has completed one vector diagram from which the TH₁ and GS₁ can be determined. However the navigator does not know the rate at which the aircraft has been leaving the departure base. Remember that the departure base has been moving at a uniform speed along a straight line toward the alternate base B.

Notice that the vector diagram is worked for one hour and the navigator can locate

the aircraft at point P at the end of that time. Also, the moving base would be at D on the line joining AB at that time. The rate of movement of the base, sometimes called the hourly increment (HI), was found by dividing the total distance between bases (300 nautical miles) by the total allowable time (T), four hours. Then to find the rate of departure of the aircraft (S₁) a constant bearing line is drawn and measured from P to D.

Before the navigator can complete the problem, the rate at which the aircraft will converge upon the moving base after the turn is made must be determined. Knowing the rate of departure (S₁) and the rate of return (S₂) the navigator obtains the time of turning to intercept, by substituting in the familiar formula,

$$t = \frac{T \times S_2}{S_1 + S_2}$$

In order to find the aircraft's rate of return, or S₂, the navigator projects the constant bearing line PD indefinitely to the opposite side of the AB line. Then with a center at the end of wind vector W and radius the aircraft's TAS, to scale, an arc is drawn cutting the extended PD line at point P'. Then AP' must be the TC₂ (course to fly after the turn) and the GS₂ is scaled along this line. The TH₂ is then drawn and measured from the end of the wind vector W to intersection point P'.

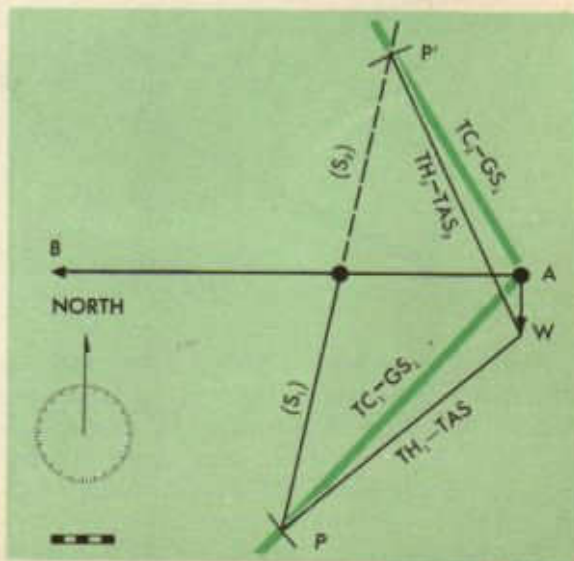
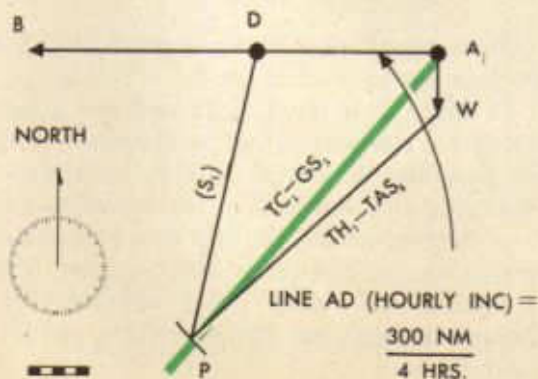

Knowing the time (little t) that can be spent on TC₁ and the GS₁ on that course, the navigator can determine the turning point. This is the aircraft's radius of action or the point at which the flyer changes course from TC₁ to TC₂ in order to arrive at the alternate base B at the exact instant the total allowable time has been used.

$$t = \frac{T \times S_2}{S_1 + S_2}$$

Now by substituting in the radius of action formula, the time of turning (t) to intercept is found to be 1 hour and 50½ minutes:

$$t = \frac{T \times S_2}{S_1 + S_2} = \frac{240 \times 107}{125 + 107} = 110\frac{1}{2} \text{ min.} \\ \text{or } 1^{\text{h}} 50\frac{1}{2} \text{ m}$$

The time to turn can be found by using the computer to solve the above formula. Read (little t) in minutes on the outer scale above (big T) on the inner scale after placing S₂ on the outer scale above the sum of S₁ and S₂ on the inner scale.

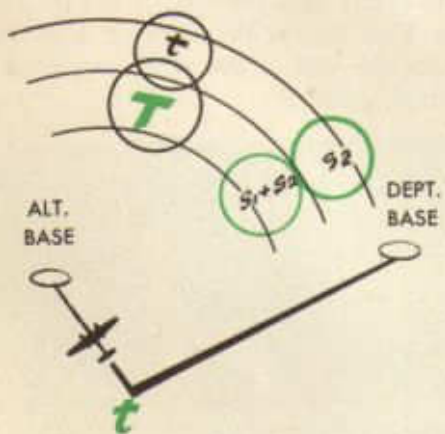

Radius of action logbook procedure is essentially the same as the D.R. logbook procedure described previously. In keeping a record of R/A to an alternate base, the log entries are similar to those used for DR dog-leg flights.

The importance of keeping a log on every flight cannot be overemphasized. While on

R/A missions, entries such as T, HI, S₁, S₂, t, and R/A need to be added to the usual log entries. These items are listed one under the other in the proper column of the logbook.

Most training missions require the navigator to take a double drift on each leg of the R/A. This is allowed for in the total time given for the flight. Accordingly T will be two minutes less than this total time. Therefore, when the ETA to turn is figured it will be one minute greater than t.

When the turning point is reached, a position report is made in the usual manner and a double line is drawn across the log. The position, time, and other D.R. entries, are set down, and the new TC and TH are entered and worked across to MH and CH. The distance from turning point to destination is entered in the Distance to Run column. The T minus t plus one minute (for a double drift) is entered in the Time to Run column.

The ETA to destination should then correspond with starting time plus total air time. A check on your plotting can be made by drawing TC₂ from turning point on the Mercator, and measuring out this line a distance equal to T minus t times GS₂. The point now arrived at should, of course, fall on (or very near) destination.

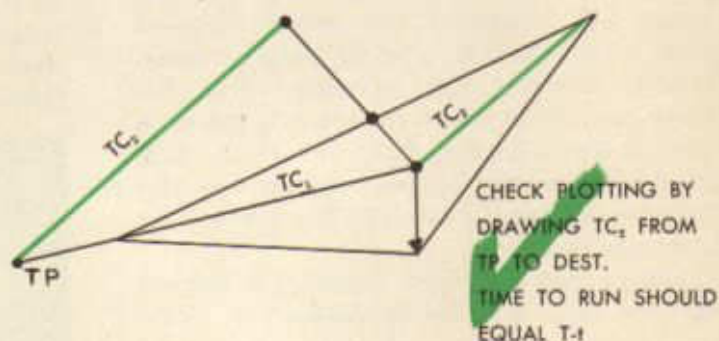

If such a check is made, it should be shown in your log as well as on the Mercator.

If there is a wind shift and the ground-speed on the second leg is changed, it may be possible to control this groundspeed by changing the airspeed in the opposite direction to compensate. In this way you can still arrive at destination on your original ETA.

Should the wind shift severely early enough in flight, the entire problem should be reworked.

RADIUS OF ACTION TO AN ALTERNATE BASE ON E-6B COMPUTER

Before working R/A to an alternate base on the computer, the distance between the bases and the bearing of base B from base A must be determined.

The student should already know the method of solution on a Mercator by vector

diagram.

If distances are too great to be drawn on a computer, all distances may be halved. The answers must be doubled before being used in the formula.

THE FORMULAE:

$$t = \frac{T \times S_2}{S_1 + S_2} \text{ or } \frac{t}{T} = \frac{S_2}{S_1 + S_2}$$

$$R/A = t \times GS_1$$

ILLUSTRATIVE PROBLEM:

Departure is at 29°21'N-99°09'W

Alternate base is at 30°51'N-99°09'W

Alternate base bears 360° and 90 nautical miles from departure. Total Time = 4 hours. Allowing 25% reserve, we get T = 3 hours.

Wind is from 135° at 20 K.

Plane is to patrol a TC of 270° at TAS of 150 K.

1. Set distance over time (T) and read hourly increment at arrow.

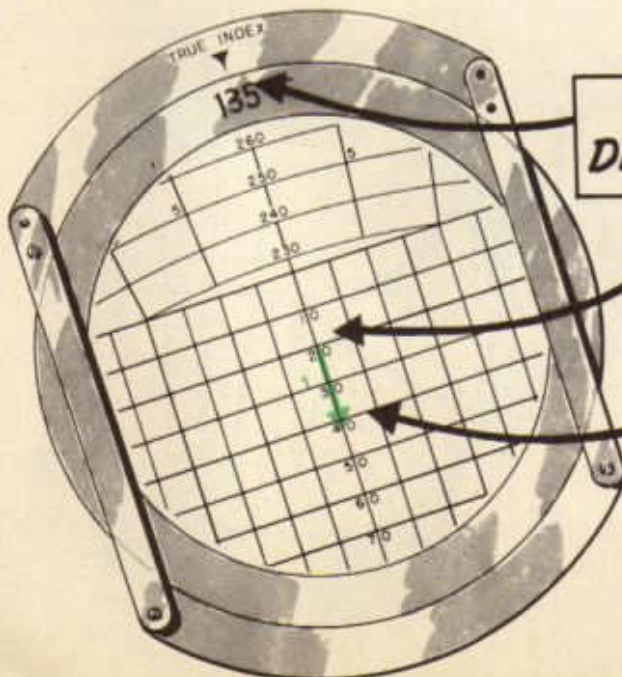
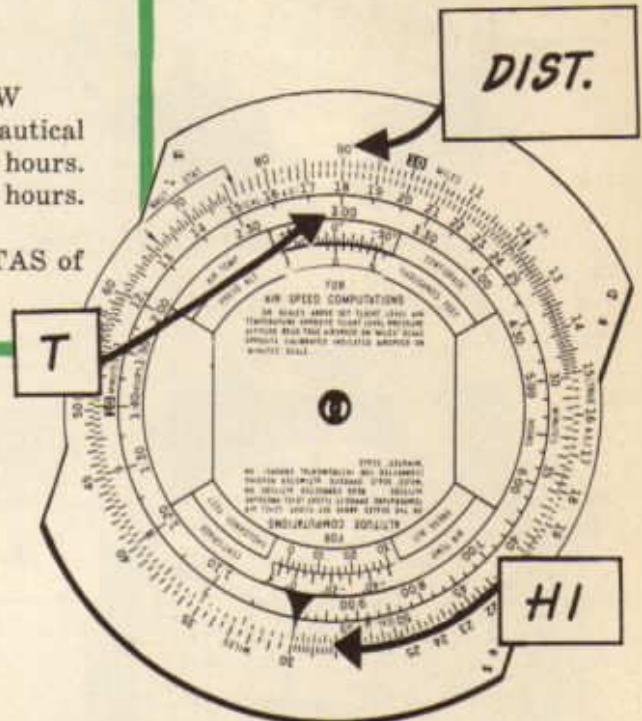

2. Place rectangular grid under computer face.
3. Place wind direction under True Index.
4. Draw wind arrow (1) down from

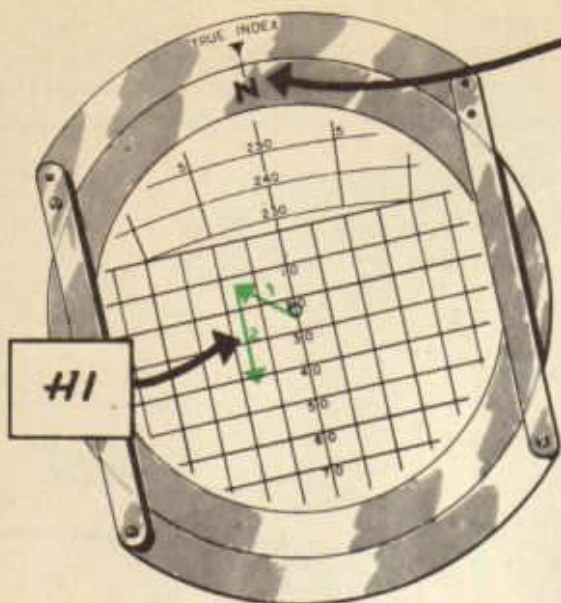

**BEARING OF
"B" FROM "A"**

grommet.

5. Place bearing of alternate base under True Index.

6. Draw HI arrow (2) down from end of wind arrow.

7. Place course to patrol under True Index.

8. Draw vertical line (3) at end of wind arrow (1).

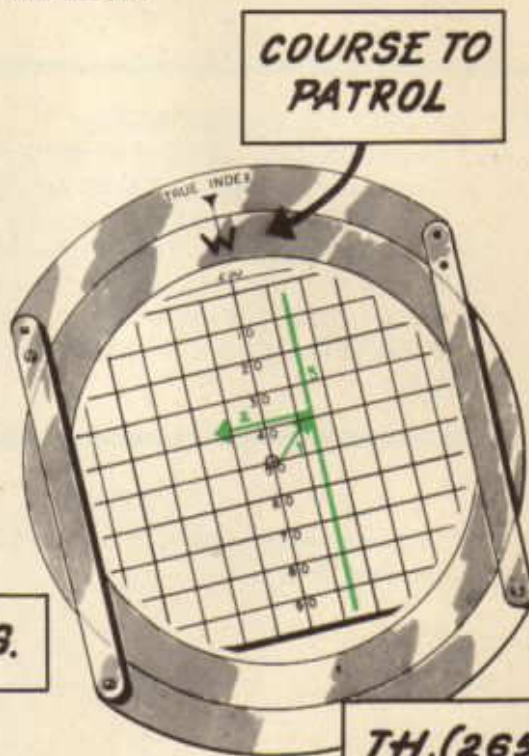

T.A.S.

TH, (265°)

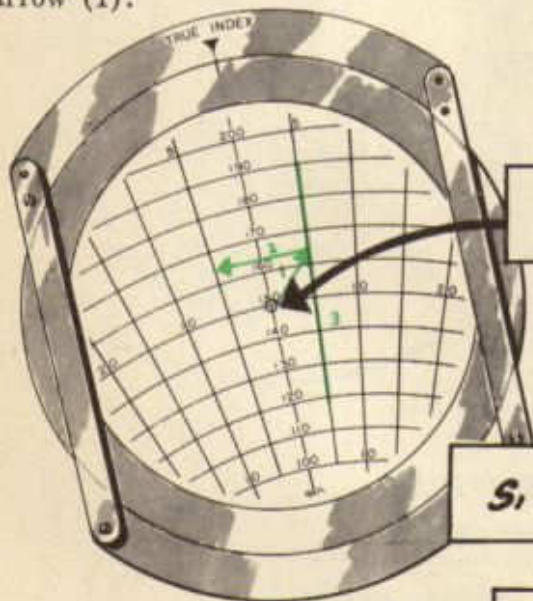

S, 166

GS, (163K)

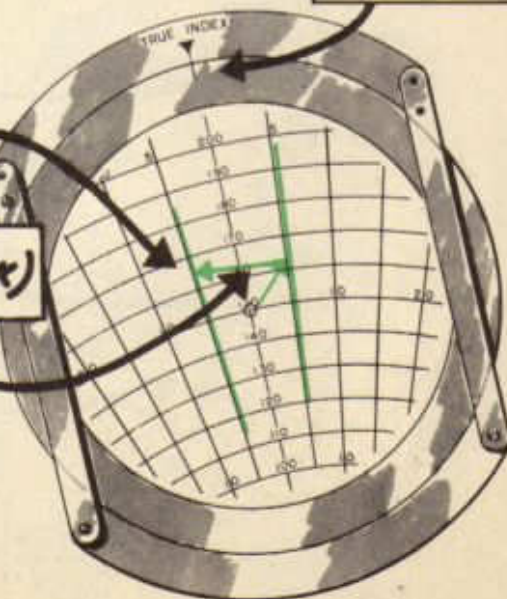

9. Place circular grid under computer face.

10. Place TAS under grommet.

11. Shift computer face until vertical line (3) parallels drift lines on card.

12. Read:

TH₁ under True Index.

GS₁ at end of wind arrow (1).

S₁ at end of HI arrow (2).

13. Draw in line (4) at end of HI arrow (2), paralleling drift lines on card.

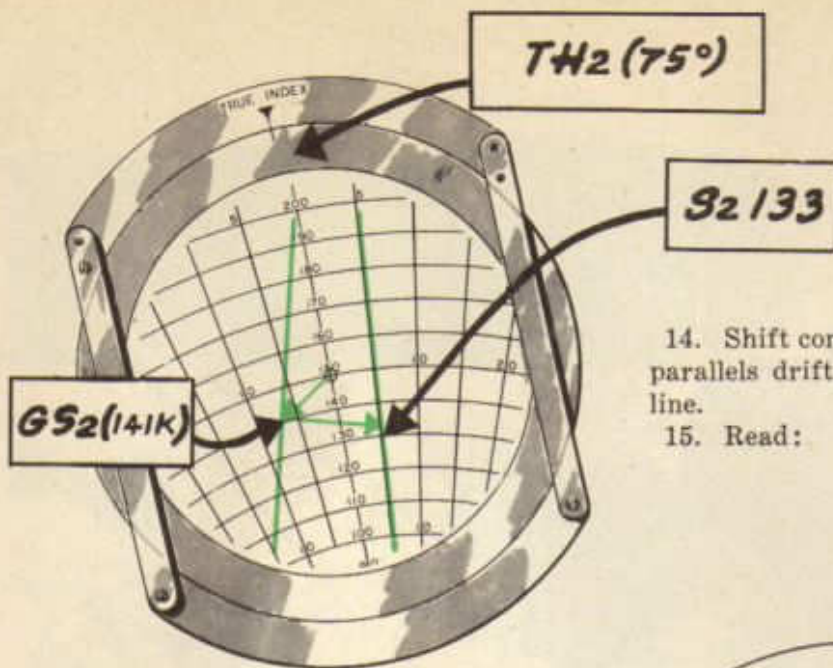

14. Shift computer face until drift line (4) parallels drift lines on opposite side of TH line.

15. Read:

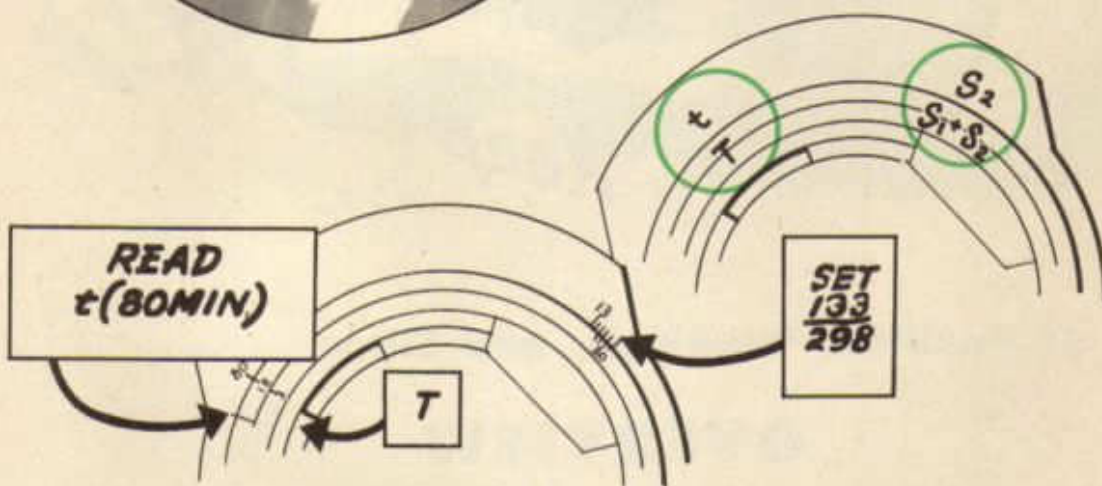

16. To find t , set up formula as shown in upper diagram. Values in illustrative problem are shown in lower diagram.

17. To find R/A set up ordinary time, speed and distance problem as shown.

ANSWERS:

Hourly Increment = 30 mi.

$TH_1 = 265^\circ$

$TH_2 = 75^\circ$

$TC_2 = 67\frac{1}{2}^\circ$

$GS_1 = 163 K$

$GS_2 = 141 K$

$S_1 = 166$

$S_2 = 133$

$t = 1^h 20^m$

R/A = 217 naut. mi.

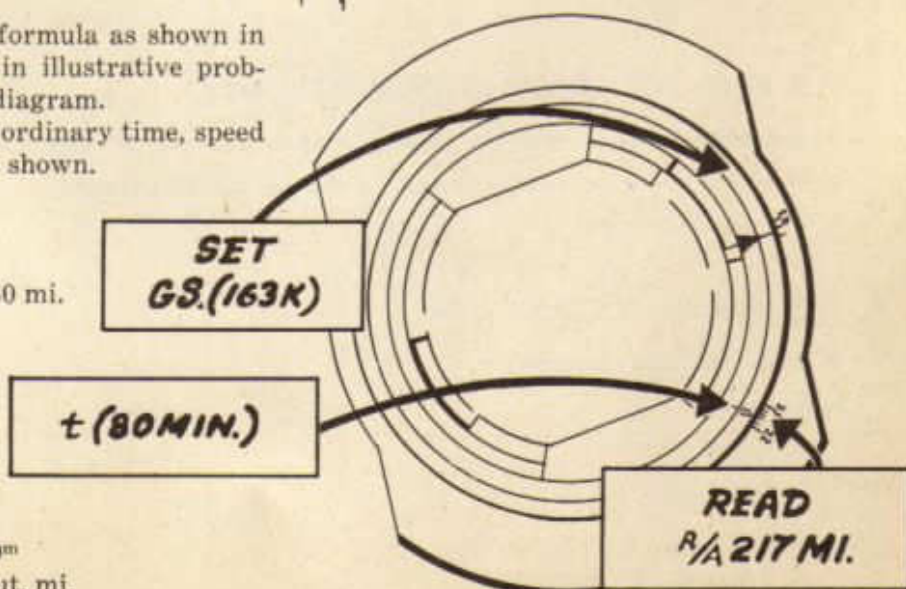



Lines of Position, Bearings, and Fixes

OVERVIEW

I. THE NEED FOR CHECKING DEAD-RECKONING

- A. Reliability of dead-reckoning dependent upon accuracy of calculations
- B. Need for checking dead-reckoning calculations by observations
- C. The idea of origins

II. THE LINE OF POSITION (LOP)

- A. Basic idea and examples
- B. Kinds of LOP's
 - 1. Visual
 - 2. Geographic
 - 3. Radio
 - 4. Celestial

- C. Types of LOP's
 - 1. Course lines
 - 2. Speed lines
- D. Advancing an LOP

III. BEARINGS

- A. Basic idea and measurement of bearings
- B. True, magnetic, and compass bearings
- C. Relative bearings
- D. Relations between true and relative bearings
- E. Reciprocal bearings and LOP's

IV. THE FIX

- A. True fix: intersection of two or more simultaneous LOP's
- B. Running fix by advancing one or more LOP's
- C. Order of taking LOP's for fix; course line to advance to speed line
- D. Spacing LOP's to get good cut
- E. Fix from three LOP's
 - 1. Order of taking LOP's
 - 2. Advancing LOP's
 - 3. The "cocked hat"
- F. Combining various kinds of LOP's to get a fix

V. PLOTTING AND LABELING LOP's AND FIXES

- A. Plot LOP's to be advanced as broken lines
- B. Plot LOP's establishing a fix as solid lines
- C. Labeling LOP's
- D. Indicating and labeling fixes

VI. AIRCRAFT INSTRUMENTS FOR MEASURING BEARINGS

- A. Driftmeter
- B. Compass
- C. Astro-compass
- D. Radio instruments
- E. Celestial instruments
- F. Leading or trailing edge of wing, etc.

LINES OF POSITION, BEARINGS, AND FIXES

In previous chapters the importance of dead reckoning to navigation has been emphasized. It should be remembered that navigation contains one basic element, dead reckoning, which is supplemented by three aids: map-reading, radio, and celestial. Dead reckoning is considered the fundamental element of navigation because it is the only method available at all times. The aids to dead reckoning listed above may become ineffectual while flying over water, above an overcast, or during a storm. A reckoning of the course and speed must be kept or an aircraft will be continuously lost, except during instances when definite positions are determined by map-reading, radio, and celestial.

lated course, distance, time, and wind. Since dead reckoning computations may be in error at almost any instant during a flight, there is need for checking the aircraft's position by means other than dead reckoning. When flying over water or above an overcast, the aircraft's position may be checked by means of visual or radio observations of a known object. This object may be a mountain peak, a radio station, or celestial body and will be hereafter referred to as the *origin*. The use of visual or radio observations of an origin to fix the position of an aircraft involves the use of lines of position.

A *line of position* should be thought of as

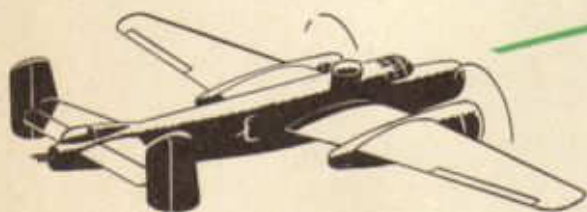

Therefore dead reckoning is never abandoned by the trained navigator. The accuracy of DR depends on the reliability of the calcu-

a line upon which the navigator is certain the aircraft is located. This may be a line on the surface of the earth such as a river, a coast line, or a railroad track, or it may be only a line drawn on a chart or plotting sheet.

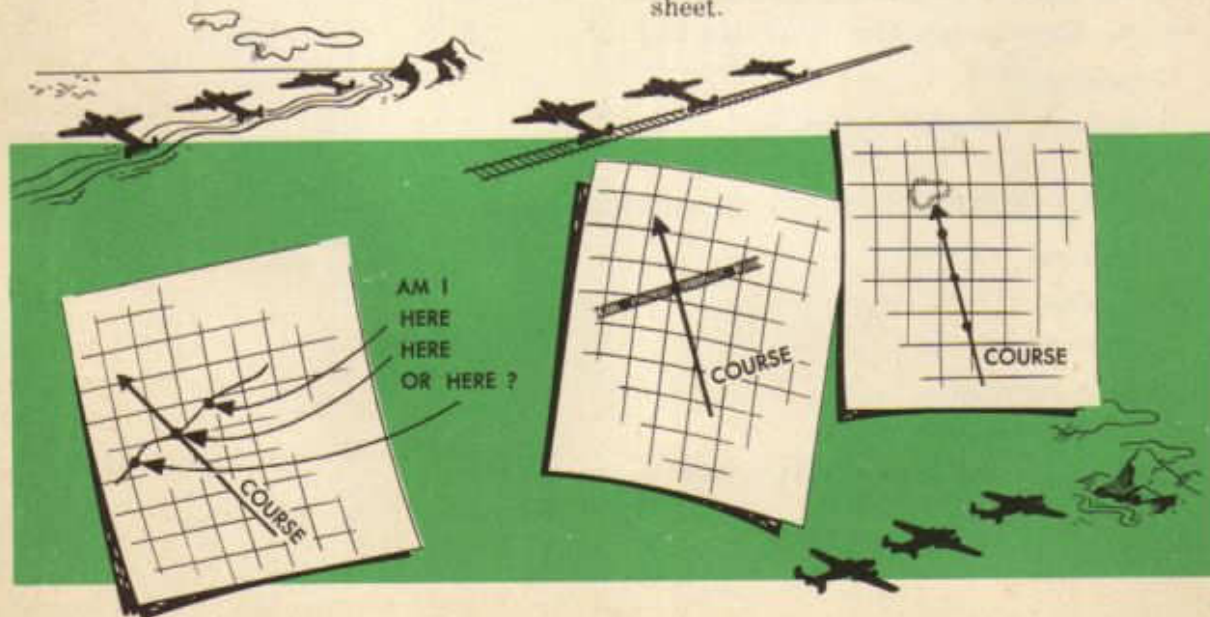

An aircraft is located somewhere on each of the lines of position shown; however the navigator does not know the exact position of the aircraft on the line.

If an aircraft is located on two lines of position at the same instant, it must be at the intersection of these lines. In the illustration below an aircraft crosses a well known river while flying on a line of position toward a mountain peak. It can be seen that the aircraft will be located on two lines of position at the instant of crossing the river. The navigator uses this means to locate definitely the position of an aircraft and calls the procedure *establishing a fix*. In the other illustration the aircraft flies directly over the point of intersection of two railroad tracks, thus establishing a fix.

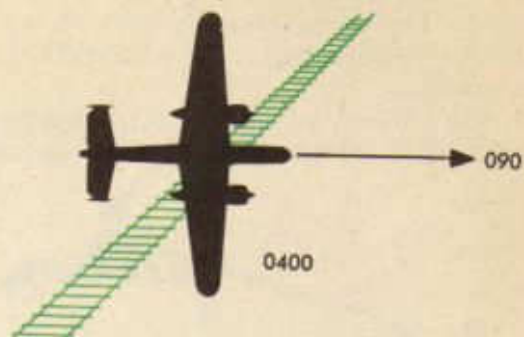
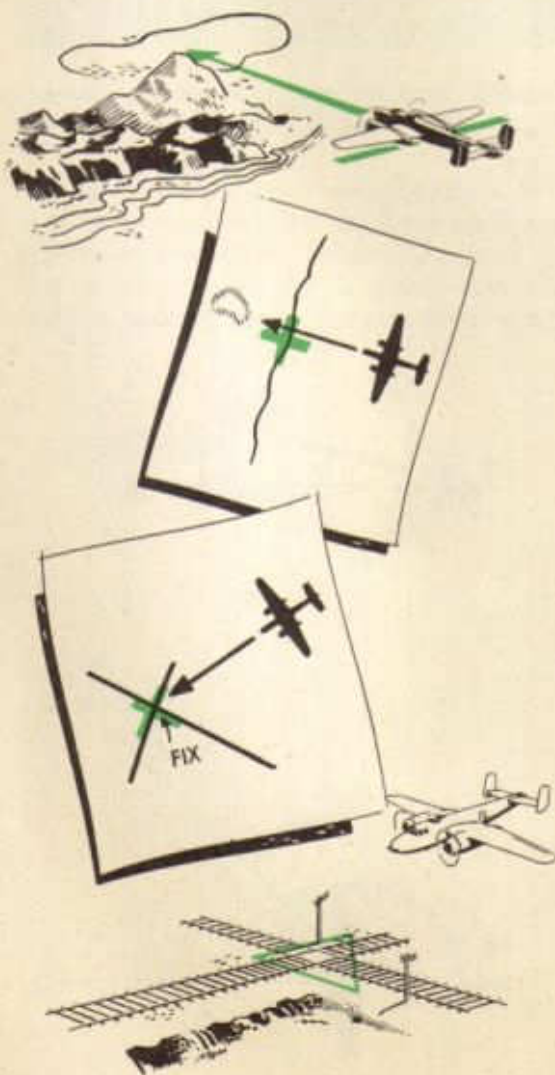

An aircraft is crossing a railroad track at 0400. This establishes a line of position. At the time of crossing the railroad track the aircraft is making good a track of 090 and a groundspeed of 120 knots. Suppose it continues at the above direction and speed for ten minutes without crossing another landmark; at 0410 the aircraft must be 20 nautical miles East of the railroad track. The broken line represents the aircraft's position at 0410. This broken line is called an *advanced line of position*.

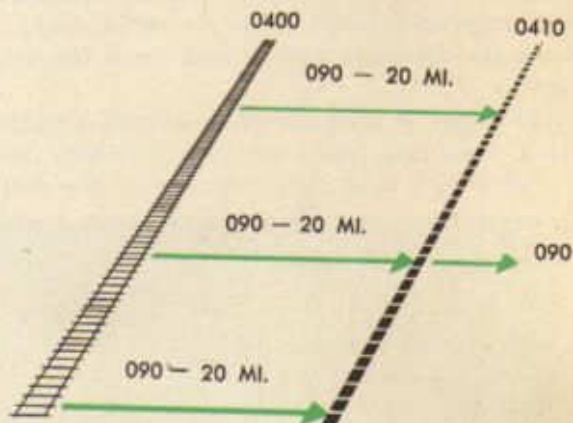

An understanding of bearings is necessary if lines of position are to be used for fixing the position of an aircraft. The direction of an object from an aircraft expressed as an angle measured clockwise from some reference point is called a *bearing*. Bearings are named according to the reference points from which they are measured. For example, the direction of an object from an aircraft

measured clockwise from True North is called a **TRUE BEARING**. The direction of an object from an aircraft measured clockwise from the longitudinal axis of the aircraft is called a **RELATIVE BEARING**. For example:

The nose of the aircraft is pointed to true north and the navigator sights a mountain

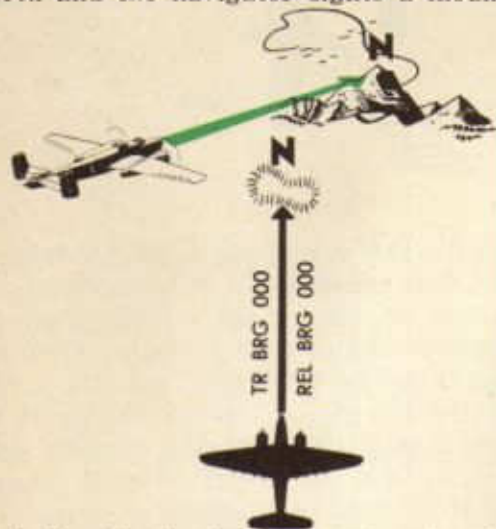

peak directly ahead. The true bearing of the peak is zero because it lies on a straight line in the direction of true north from the aircraft instead of at an angle. The relative bearing of the mountain is also zero because the longitudinal axis of the aircraft coincides with the direction of the peak from the aircraft.

The nose of the aircraft is pointed directly at a mountain peak that lies half way between North and East. By use of the defi-

nition of a true bearing it can be seen that the angle measured clockwise from true north to the peak is 045. The relative bearing of the peak is zero because the aircraft's longitudinal axis is in line with the direction of the peak.

The aircraft's nose is pointed East toward a mountain peak. The true bearing measured clockwise from true north to the peak is 090 and the relative bearing is zero because the

aircraft's longitudinal axis still coincides with the direction of the mountain from the aircraft.

The aircraft's nose is pointed due East and a mountain peak lies half way between North and East. Measuring the angle clockwise from true north to the peak gives a true bearing of 45 degrees, while the angle meas-

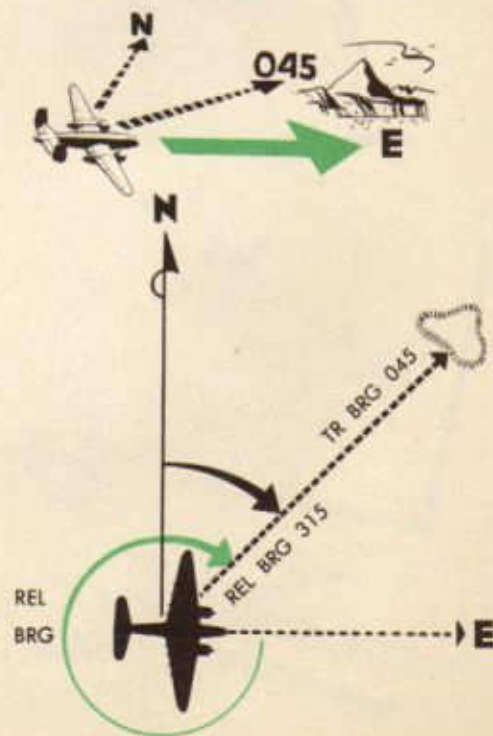

ured clockwise from the longitudinal axis of the plane to the peak gives a relative bearing of 315.

The true bearing of the aircraft from an origin, whether it be a mountain peak, radio station or celestial body, is the bearing required for plotting, since an origin affords a known position on the chart from which to draw the desired Line of Position. The navigator's equipment does not give the *true* bearing of an origin directly. It gives what is known as a relative bearing. This relative bearing must be converted to a true bearing before it can be used.

For example, most aircraft carry radio direction finding equipment which measures the relative bearing of radio stations. The figure below is a diagram of a RDF installation in a plane. Note that 0° and 180° are in line with the fore and aft axis of the plane. Consequently the *relative* bearing of a station dead ahead of the craft, regardless of the craft's heading, would be 000 or 360°. The relative bearing of a station dead astern would be 180°. A station on the right wing would have a relative bearing of 090° and one on the left wing a relative bearing of 270°. Obviously, to determine the true bearing of these stations, the direction the craft is pointing or its *true heading*, must be considered.



The diagram below shows a craft on a true heading of 090°. A radio station dead ahead would have a relative bearing of 000 or 360°. Note that the true bearing of the station from the aircraft would be 090°. A station on the aircraft's right wing would have a relative bearing of 090°. Its true bearing from the aircraft would be 180°. The relative bearing of a station dead astern would be 180°, its true bearing 270°. A station on the left wing would bear 270° relative. Its true bearing would be 360°. Notice that in every case the *true bearing* of the station is equal to the *relative bearing plus the true heading* of the aircraft. The above method can be used to obtain the true bearing of any origin.

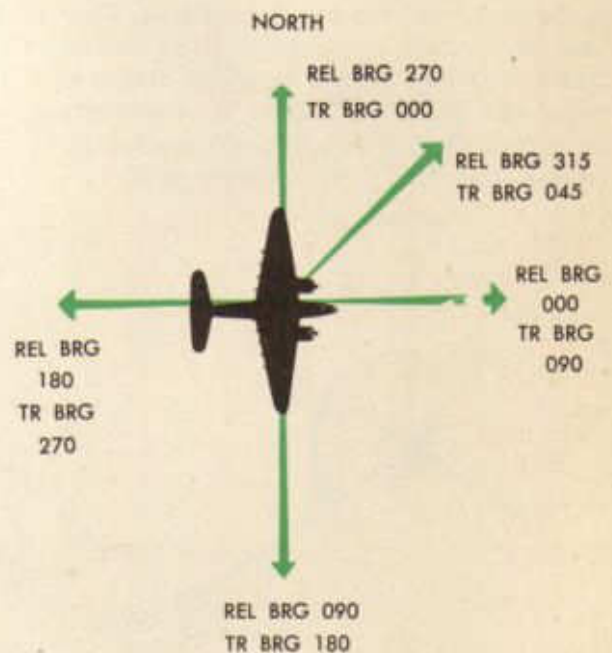

Occasionally it may be desirable to secure the relative bearing of an origin, knowing its true bearing and the aircraft's true heading. In this case the relative bearing is equal to the true bearing minus the true heading. (Add 360 degrees, if necessary, in order to subtract.)

As stated before, the navigator's equipment measures the bearing of an origin from the aircraft. The navigator does not have a point from which to plot such a bearing since the aircraft's position is uncertain. (Its dead

reckoning position is merely an estimated position that is being checked.) However, the navigator does know that if an origin bears 0° from the aircraft, the aircraft bears 180° from the origin. In a case where an origin bears 90° from the aircraft, the aircraft bears 270° from the origin. In other words, the bearing of the aircraft from the charted position of an origin is the exact opposite, or RECIPROCAL, of the bearing of the origin from the aircraft. The true bearing of the aircraft from an origin is, therefore, obtained by adding 180° to the true bearing of the origin from the aircraft. Always remember that the true bearing of the aircraft from an origin is the bearing required for plotting since an origin affords a known position on the chart from which to draw the desired line of position. Thus a true bearing of 120° obtained by the navigator would be plotted from the origin as a reciprocal bearing of 300° . It is important to remember that the line of position must always be plotted from a known point.

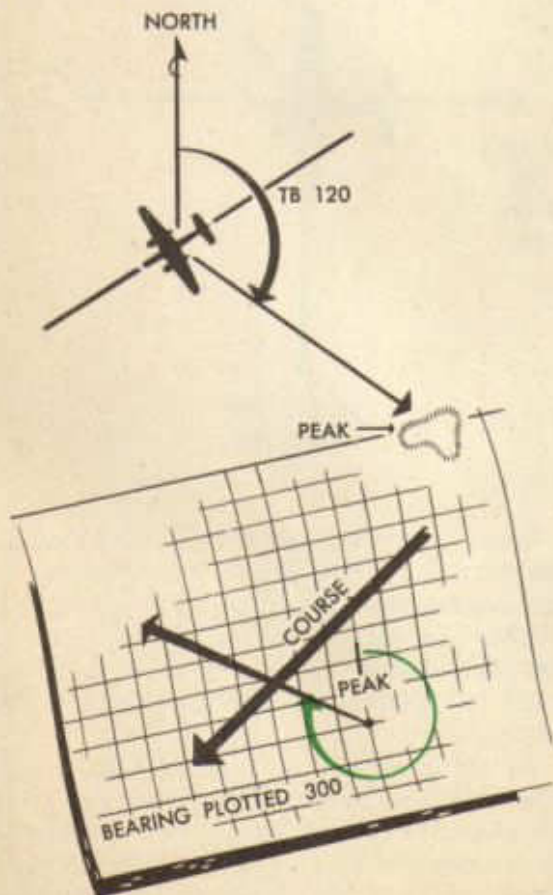

At present the navigator does not have an instrument for finding more than one line of position at a time. Therefore, a period of minutes sometimes intervenes between the times of obtaining the bearings required for a fix. Since the intersection of two or more lines of position for different times would not indicate the position of the aircraft at any one given instant, the lines of position must be advanced to a common time. A fix obtained by advancing LOP's is known as a *running fix*. A running fix is usually obtained by advancing all lines of position to the time of the last one obtained.

To advance an LOP from the instant of obtaining the bearing to a later time desired for a fix, the course and the predicted ground-speed of the aircraft must be considered. For example, suppose an aircraft were traveling on a course of 045° with a groundspeed of 120 knots. At 120 knots groundspeed the aircraft will travel over the ground at a speed of two miles per minute. At 1050 the navigator found by use of the RDF set that the aircraft was somewhere on a line that bears 270° from a known radio station. If this speed and direction were continued for ten minutes at 1100 the aircraft would have moved to a new line of position, parallel to the first a distance of 20 nautical miles along its track. Notice that the original line of position was advanced in the direction of movement over the ground the distance traveled in ten minutes. Remember to use the track and not the heading when advancing lines of position. Lines of position must be advanced in the manner described above regardless of the manner in which they were obtained.

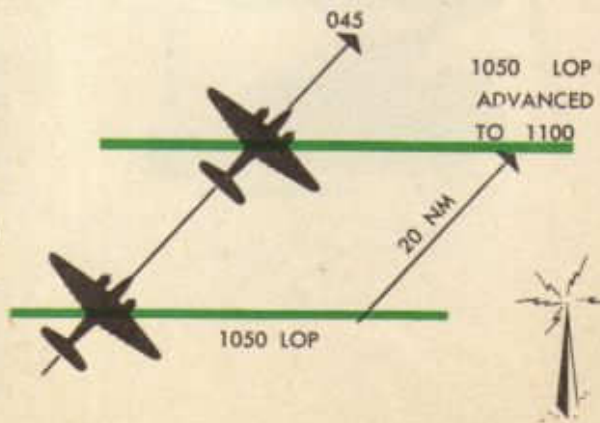

It is possible to obtain a running fix by taking two bearings at different times from a single object whose position is known. By using groundspeed to advance the first bearing along the aircraft's track to the time of the second bearing the running fix is obtained.

A fix can be obtained by taking a bearing on two objects. First take a bearing on some object nearly ahead of or nearly behind the aircraft. When the reciprocal of the bearing thus obtained is plotted it will be found that it nearly parallels the aircraft's track. Because of this feature it is called a *course line* and is always taken first. The next step is to take a bearing on some object to the right or left of the aircraft. This object should be at a large angle to the other (between 60° and 90°). When the reciprocal of the bearing thus obtained is plotted, an LOP cutting the aircraft's track near the perpendicular is obtained. Due to this feature, it gives a much better indication of the

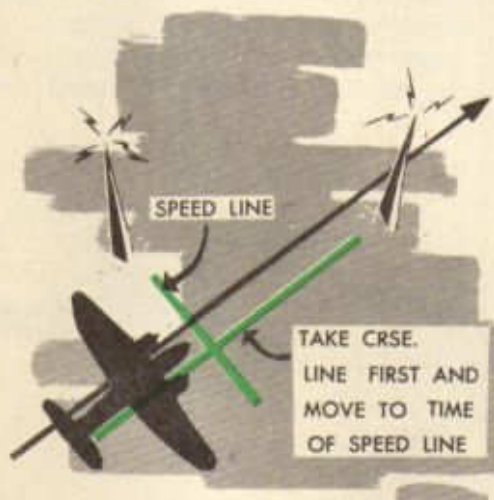

aircraft's groundspeed and is called the *speed line*. The course line can be moved up to the time of the speed line to obtain a running fix.

It is also possible to obtain a fix by taking a bearing on three objects. First a bearing is taken on an object just ahead or behind the aircraft to establish a course line. The other two objects should be selected so that they will be between 100° and 120° from the

course line and each other. Because there are three bearings, there will be three different times to deal with. In this case the first two bearings must be moved up to the time of the third bearing. Here is a situation where we have an intersection of three lines of position; this intersection will cause a triangle to be formed (just as a wind star is formed on a computer in calculating a double drift). This triangle is called a "cocked hat" in British navigation. We must select a definite point from the triangle formed and the point that is selected is really the intersection of the three lines bisecting the angles of the "cocked hat." This point is considered the fix position.

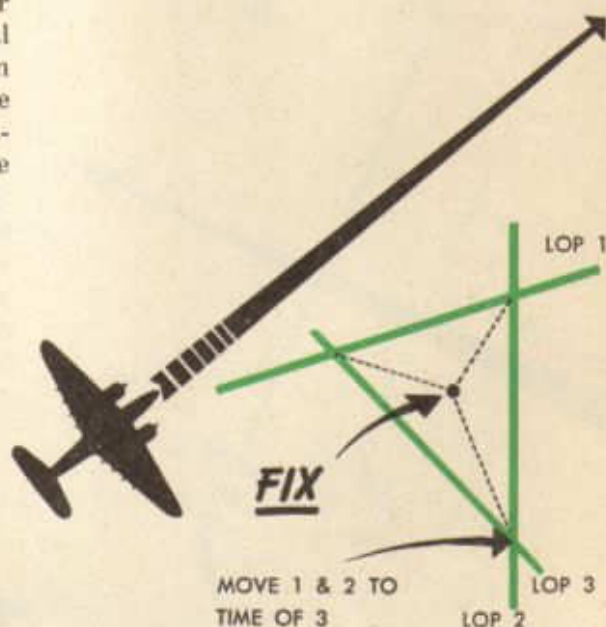

Visual bearings can be used with other bearings. One might want to cross an LOP secured from a radio bearing with an LOP secured from a visual bearing. Many times a navigator can obtain only one line of position. Even though this cannot give a fix position, it is very useful for it can usually give the groundspeed or distance off course. While on a patrol mission, the navigator can make very good use of visual bearings to establish the position of an enemy force.

The navigator should adopt a standard method for labeling LOP's. Lines of position intersecting to establish a fix should be drawn as solid lines. Above the line should be indicated the reference point upon which the bearing was taken, as well as the time of the bearing and the time to which it was advanced or retired.

A line of position which is to be advanced should be drawn as a broken line. Above the line the reference point and the time of the bearing should be indicated. Below the line the true bearing of the reference point from the aircraft should be shown.

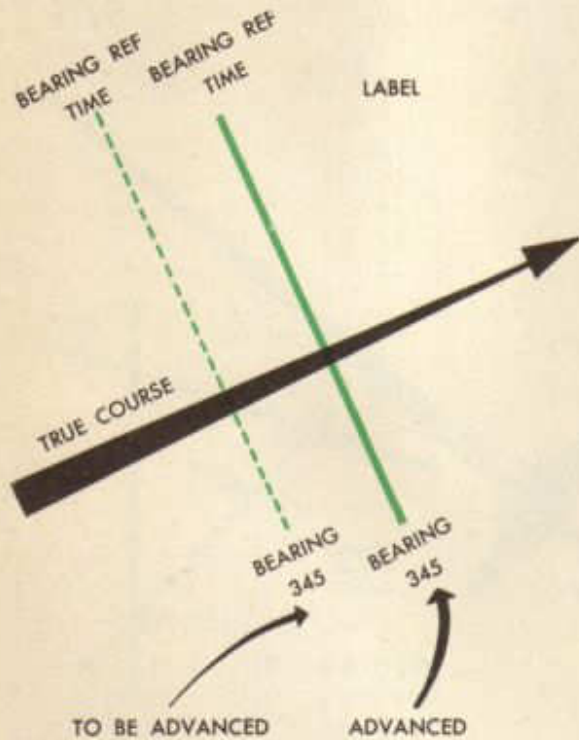

A relative bearing was defined above as the angular direction of an object measured clockwise from the true heading of an aircraft. It is necessary therefore to have some instrument within the aircraft with which the navigator can measure this angle. One such instrument is the *driftmeter*. By sighting an object through the driftmeter and placing the intersection of the center grid lines and the center transverse wire on that object, one can read the relative bearing of

that object on the azimuth scale of the driftmeter. By always using the full benefit of the trial angle, one will always read the correct relative bearing from the azimuth scale. The time should also be read immediately upon



reading relative bearing.

Another instrument that can be used to measure relative bearings is the astro-compass. This instrument is so installed in the aircraft that when the sighting device is in line with the longitudinal axis of the aircraft the azimuth scale reads zero. Therefore, providing the instrument is turned in a clockwise direction, the relative bearing of the object sighted is read on the azimuth scale. The time should be read immediately upon sighting the object.



There are a few other methods which may be used in the absence of precise instruments to measure relative bearings. By sighting off the leading edge of the wing, one can determine when the aircraft is 090 or 270° from the object. By placing a compass rose in an appropriate position in the aircraft and by having the 360° mark in line with the longitudinal axis of the aircraft, one may sight an object and read the approximate relative bearing of the object off the compass rose. Navigators on tactical duty sometimes calibrate the top gunner's turret so that when the gun is aimed at any point the relative bearing may be obtained.





Supplementing Dead-Reckoning by Radio

OVERVIEW

I. THE RADIO LINE OF POSITION

A. The instruments and their use

1. The antennas

a. The direction-finding loop

- (1) Maximum and minimum positions
- (2) Aural null

b. Other antennas

- (1) The non-directional antenna and the left-right indicator
- (2) The visual null

2. The receiver

a. The remote control panel

b. Tuning the receiver from the remote-control panel

- (1) Position switch
- (2) Control button
- (3) Band change switch

- (4) Tuning crank
- (5) Tuning meter
- (6) Audio knob
- 3. The azimuth dial
 - a. The manually-operated dial
 - b. The automatic dial
- B. Obtaining the uncorrected radio bearing
 - 1. The aural null method
 - 2. The visual null method
 - a. The manually operated azimuth dial
 - (1) Select antennas
 - (2) Tune receiver
 - (3) Note left-right indicator
 - (4) Turn azimuth dial crank
 - (5) Check azimuth dial, time, and compass heading
 - b. The automatic azimuth dial
 - (1) Select antennas
 - (2) Tune receiver
 - (3) Check azimuth dial, time, and compass heading
- C. Converting uncorrected radio bearing to radio line of position
 - 1. Uncorrected radio bearing (indicated relative bearing)
 - 2. Quadrantal correction
 - 3. Corrected radio bearing (corrected relative bearing)
 - 4. True heading of aircraft
 - 5. True radio bearing (station from aircraft)
 - 6. Chart (Lambert or Mercator) correction
 - 7. Reciprocal bearing (aircraft from station)
 - 8. Radio line of position
- D. The radio fix and log
- E. Other radio and communication equipment in the aircraft

II. ADDITIONAL RADIO AIDS

- A. Radio range stations
- B. Marker beacons
 - 1. Class M markers
 - 2. Class Z markers
 - 3. FM (fan marker) beacons

RADIO

The Radio Line of Position

Every navigator must know how to make the fullest possible use of radio as a navigational aid. Obviously, it would be foolish to underestimate radio's importance merely because the use of radio alone does not necessarily mean safe and certain navigation under all circumstances. It should never be forgotten that the proper use of radio equipment has saved many an airplane.

Radio as a navigational aid is based on the ability of directional, loop-equipped apparatus to show the direction of the line on which radio waves move.

All such apparatus is based fundamentally on the direction-finding loop, of which there have been several refinements. The loop consists of a coil of insulated wire wound within a streamlined duraluminum housing. The plane of the loop, which is mounted on the fuselage, may be turned through 360° per-



pendicular to the horizontal plane of the aircraft. As the loop is turned, its position relative to the aircraft's longitudinal axis is shown on an azimuth scale. When the plane of the loop is perpendicular to the longitudinal axis, the needle on the azimuth scale indicates 0° or 180°.

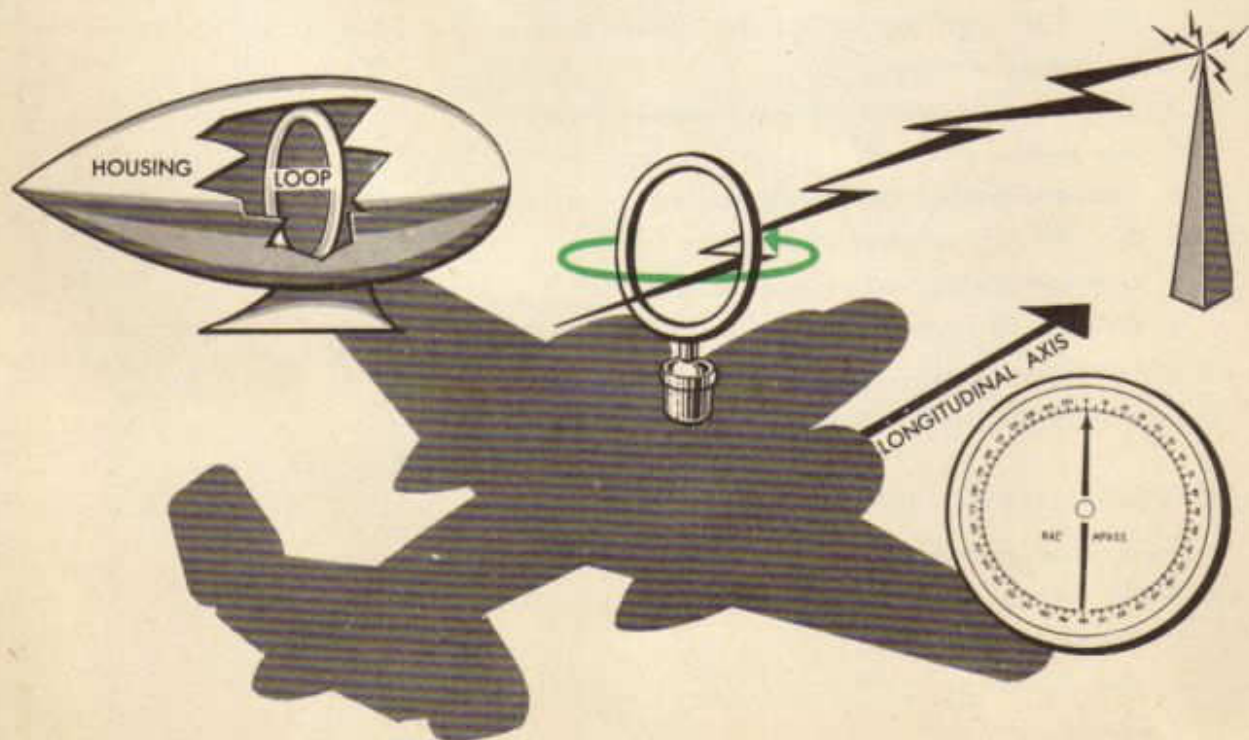

The loop's sensitivity to the direction of the line on which radio waves move is shown by the large increase or decrease of signal strength as the plane of the loop is turned. When the loop's plane is parallel to the incoming waves, the signals are strongest; the loop now is in its *maximum* position. On the other hand, the signal strength dwindles to a minimum or disappears entirely when the loop's plane is at right angles to the incoming waves; the loop now is in its *null* position.

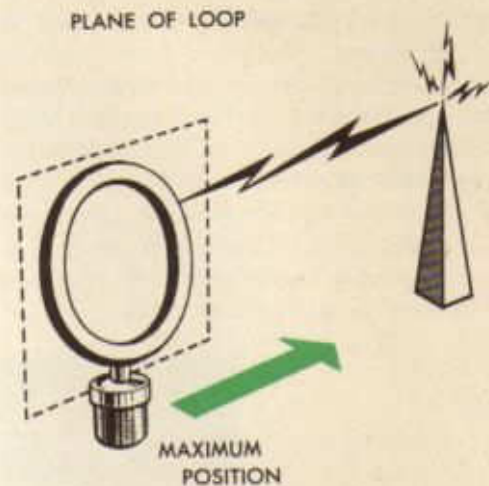
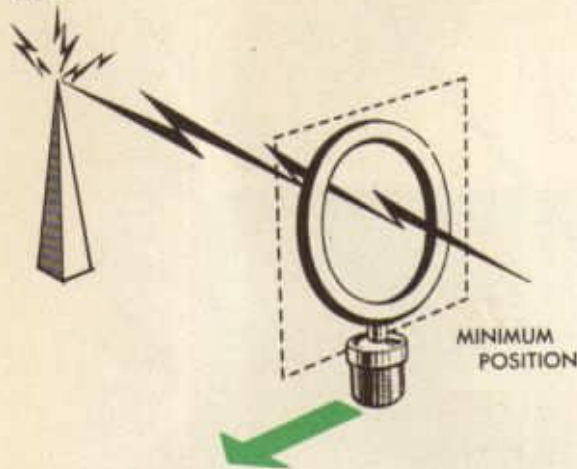

A primary fault of the simple aural-null loop is the fact that, while it shows the direction of the line on which the waves are moving, it does not show which direction the waves are coming from. The transmitting station might be right of the loop or left of it. This difficulty has been corrected by adding an attachment, a left-right indicator, which shows visually which way the station is from the airplane.

The left-right indicator is used with a non-directional antenna as well as the loop, and the waves picked up separately by each antenna are fed into a special receiver circuit which detects from which side of the loop the waves are coming.



It is a lucky thing that it is no longer necessary for the navigator to determine bearings by aural means, because the change of signal strength is so gradual that it covers a wide area on the azimuth scale. This is particularly true when the loop is in maximum position. For this reason, the null position is preferred for direction finding. Even then, the null position may vary in width from 2° or 3° to 30° . The bearing taken by the aural-null method is found by visually splitting the null width on the azimuth scale.

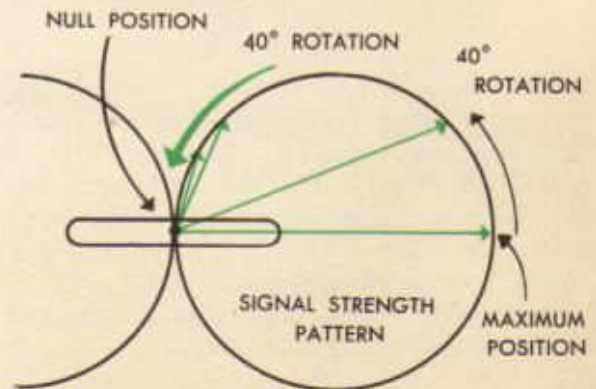

Under normal conditions, the null width is controlled by volume. High signal volume produces a sharp null, and a low volume gives a wide null. Volume is controlled by receiver volume and by the distance away from the transmitter.

Under normal conditions, use of the controls on the panel depends on the method of obtaining bearings. The radio is as easy to tune as any home model, but the tuning must be extremely accurate. Remote control panels, for the pilot as well as the navigator, include a band selector, tuning crank and meter volume or audio control, position switch, control button and light, loop L-R switch (sometimes replaced by a compass sensitivity knob), and control light.

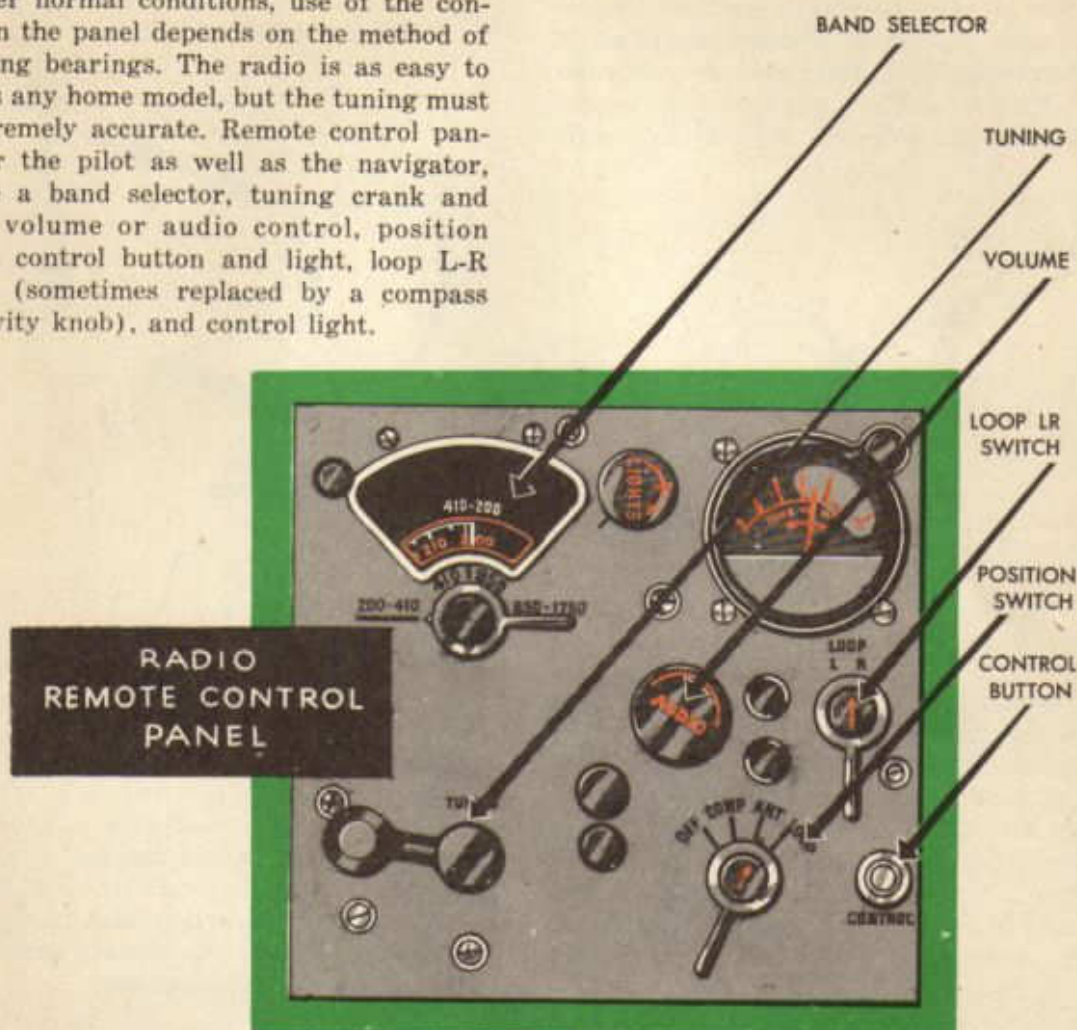

Regardless of the method by which the bearing is being taken, receivers are tuned in exactly this manner:

1. POSITION SWITCH. This activates the radio set, and selects either the non-directional antenna (ANT), the loop antenna (LOOP), or both together (COMP.).

Turn to ANT. This gives clearer reception when you are tuning in a station.

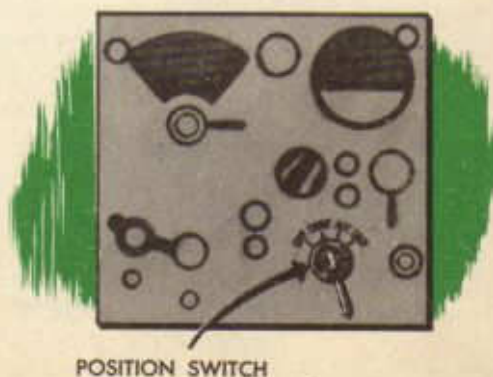

2. **CONTROL BUTTON.** This enables the operator of a remote control panel to take over operation of it. As soon as the green light is on, the radio may be controlled from the panel. If the light is not on and the position switch is on ANT, the pilot has control. If permissible, push on the control button until a clicking sound is heard and the light comes on. This operation may be repeated several times before the green light shows that control of the set has been shifted.

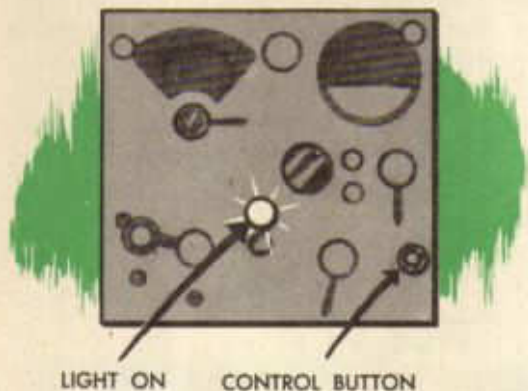

LIGHT ON CONTROL BUTTON

3. **BAND CHANGE SWITCH.** Turning the switch gives the desired one of three frequency bands: 200 to 410 KC, 410 to 850 KC, and 850 to 1750 KC.



BAND SELECTOR SWITCH

4. **TUNING CRANK.** This gives the exact frequency desired. The crank is turned back and forth until the loudest signal is heard or until the needle of the . . .

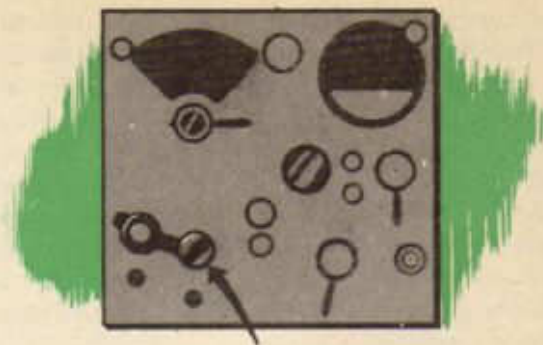

TUNING CRANK

5. **TUNING METER** is deflected as far as possible to the right. This shows the signal is the best; it is similar to the "magic eye" of home-model radios. Identify the station by means of its identification signals.

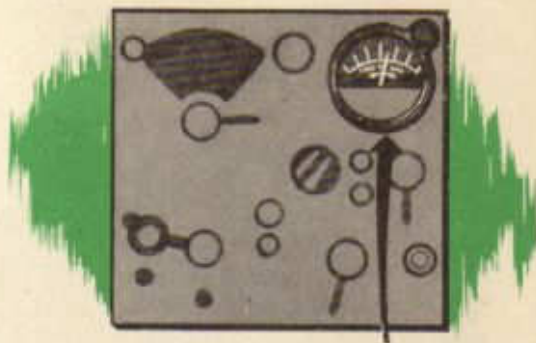

TUNING METER

6. **AUDIO KNOB** controls the volume of sound.

As a memory-aid in this procedure, remember P-C-B-T-T-A—"Pupils Can Blast Tokyo This Autumn." The initial letters, of course, stand for Position switch, Control Button, etc.



AUDIO KNOB

REMEMBER
P-C-B-T-T-A
 "PUPILS CAN BLAST TOKYO
 THIS AUTUMN"

From this point, how the radio is used for direction finding depends on which method is used. Aural-null reception requires the use of the loop only; therefore, the position switch is placed on LOOP. For the visual-null method, both loop and non-directional antennas are used; therefore, the position switch is placed on COMP. Because of its two major faults, the aural-null method is seldom used. The visual-null method is commonly employed.

Visual-null procedure employs both the left-right or visual radio compass indicator and the azimuth dial; therefore both antennas are needed. After tuning in the desired station, turn the position switch to COMP while the azimuth dial needle is placed on zero.

needle may fail to move, due to lack of power; therefore the COMPASS sensitivity knob should be rotated slightly. The movement of the left-right indicator shows the direction in which to turn the azimuth dial needle. For instance, if the indicator swings to the right, the azimuth needle is turned to the right (clockwise). When the azimuth crank is turned to the right and the left-right needle moves from the right to the center, the loop is in the correct null position. On the other hand, when the azimuth crank is turned to the left and the needle swings from left to the center, the loop is in the correct null position. As the needle reaches the center position, the COMPASS sensitivity knob should be turned to full power while the needle remains centered. The relative bearing of the transmitter from the aircraft may be read directly from the azimuth dial.

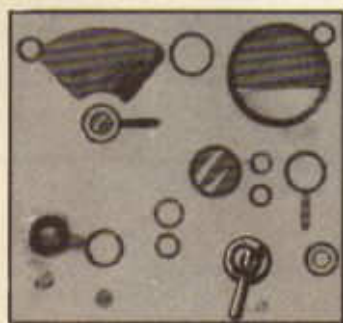

POSITION ON COMP.

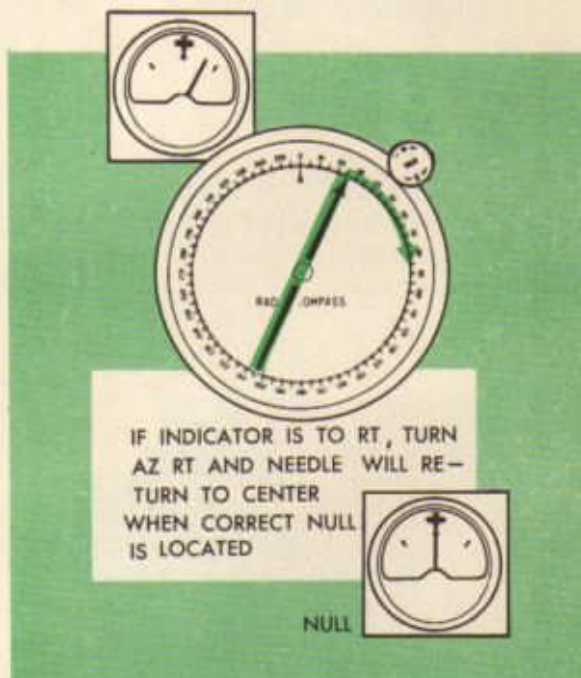
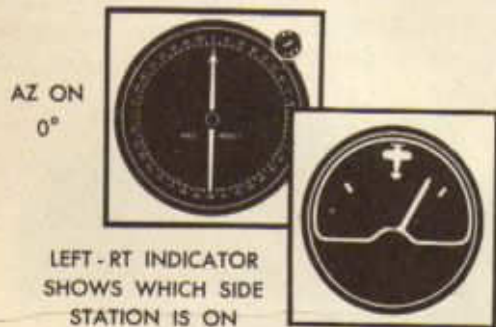

The needle of the left-right indicator immediately swings to the right or left, provided the radio waves are not entering the loop along the longitudinal axis of the aircraft. In that event, the needle remains centered, showing that the transmitter is directly ahead or behind the aircraft. The

At various times, when the left-right needle is centered at the beginning, there may be some doubt as to whether the station is directly ahead or astern. This may be cleared up by turning the azimuth crank to the right. If the left-right needle swings to the right, the transmitter is behind the air-

craft. If the needle swings left, when the loop is turned to the right, the transmitter is ahead of the aircraft. This is of particular interest to pilots when "homing;" however, in that instance the aircraft is turned instead of turning the loop.

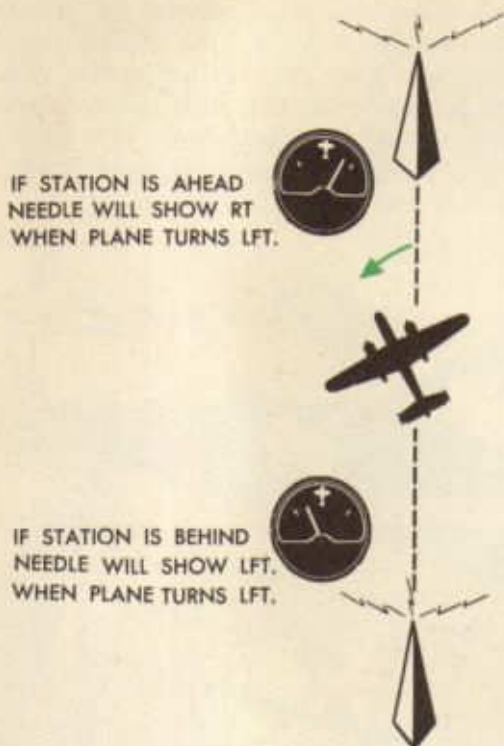

At the instant the left-right needle is definitely centered, the azimuth indication, compass reading, and time must be noted. With this data, in addition to a knowledge of the radio and compass errors, the navigator can calculate a corrected relative bearing. Since relative bearing is the clockwise angle between the true heading of the aircraft and the object, it is necessary to calculate true heading by applying variation and deviation to the compass reading at the time the bearing was taken.

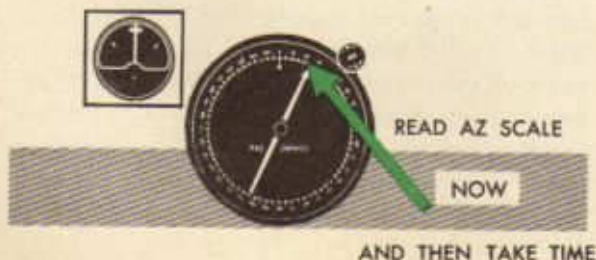

But the radio, like the compass, is subject to error; for this reason, a correction must be applied to the indicated bearing in order to get a corrected relative bearing. *Quadrantal error* is caused by the bending of the radio waves by the metal and electric currents in the aircraft. The term "quadrantal" is used because the error is greatest at the quadrantal points measured from the longitudinal axis of the aircraft. The bent waves give a false indication of the direction of the transmitter. This error can be measured by ground swinging, but the preferred procedure is to take bearings over a known position while in flight. The correction for this error is usually found recorded near the azimuth dial in the form of a correction curve. Applying this correction to the indicated relative bearing results in a *corrected relative bearing*.

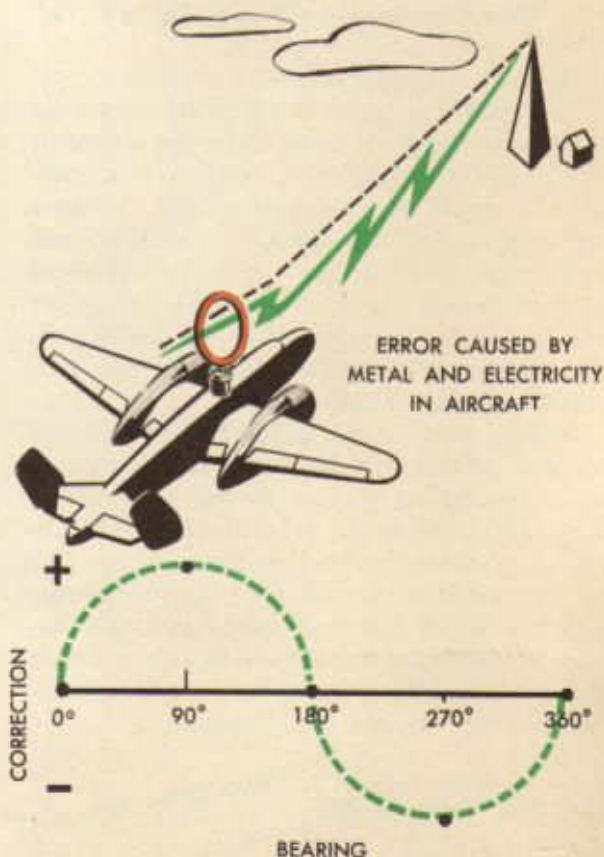

QUADRANTAL ERROR

Since true heading is measured from true north to the longitudinal axis of the aircraft, and since relative bearing is measured from this point to the object, the sum of the two is the *true bearing* of the object from the aircraft. In other words, $TH + \text{corrected RB} = TB$.

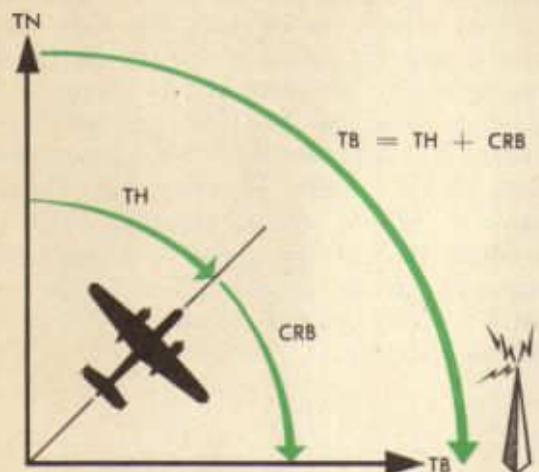

Recent improvements have made it possible to design a receiver which automatically indicates relative bearing when the station is tuned in. The equipment consists of a combined control and indicating unit, a sense antenna, a specially designed receiver, and a pair of shielded loops mounted at right angles. Tuning the set is the same, except for the fact that the azimuth needle automatically indicates the relative bearing. The left-right indicator is not needed.

Besides being much quicker, the automatic set may be compensated for quadrantal error by adjusting 24 screws in the base of the loop. This permits the azimuth needle to indicate corrected relative bearing directly. One of the great advantages of the automatic compass is the fact that, once tuned to a station, it continues to indicate the direction of that station regardless of the aircraft's heading or progress over the ground.



Knowing the true bearing of the transmitter from the aircraft and the exact location of the transmitter, the navigator can determine a line of position for the aircraft. This bearing is, in effect, an extension of a visual line of sight which provides all possible locations of the aircraft at a particular instant. Since the exact position of the aircraft is unknown at the time the bearing is obtained and since the location of the range station is known, the true bearing is changed by 180° in order to plot from this known position. Thus, the true bearing of the aircraft from the station is obtained.

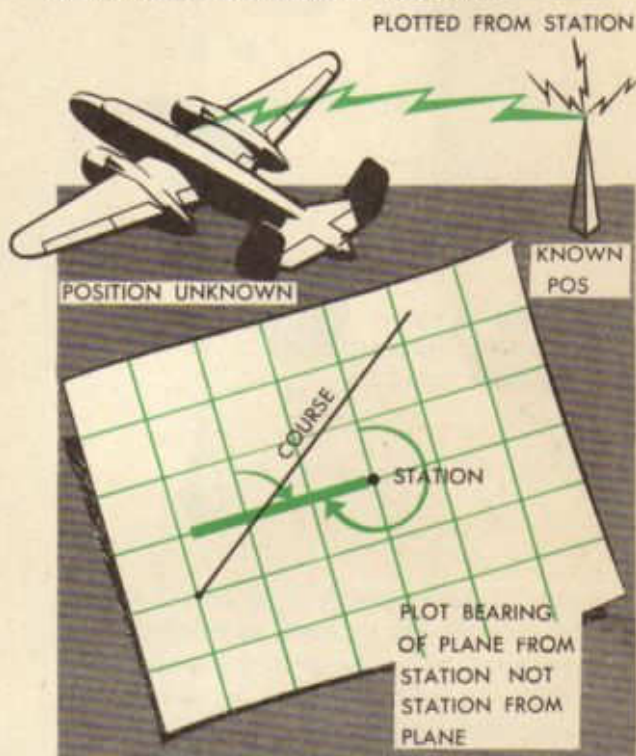

Before plotting the line of position, the navigator must remember that radio bearings travel in great circles over the earth. These great circles do not cut all meridians at the same angle except along the equator; therefore the type of chart upon which the bearing is plotted governs the plotting technique. For instance, aeronautical charts for radio direction finding are constructed on the Lambert conformal conic projection. Only a slight correction must be made when plotting radio bearings. On the other hand, a larger correction is necessary when plotting on Mercator charts.

Regardless of the type of chart, the correction is always made in the same manner. If the aircraft is east of the radio station, subtract; if the aircraft is west, add. The rule, "East is least, and west is best," may be applied whenever bearings are taken by the aircraft in the northern hemisphere. The opposite is true south of the equator. The correction is always applied at the point from which the bearing is taken toward the equator.

NORTHERN HEMISPHERE

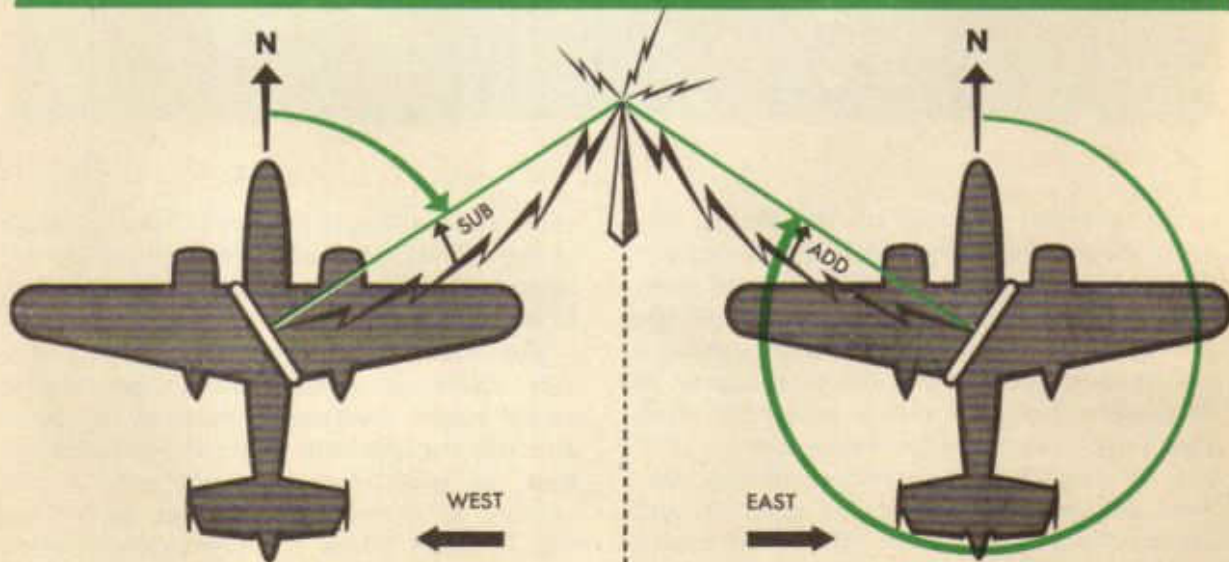
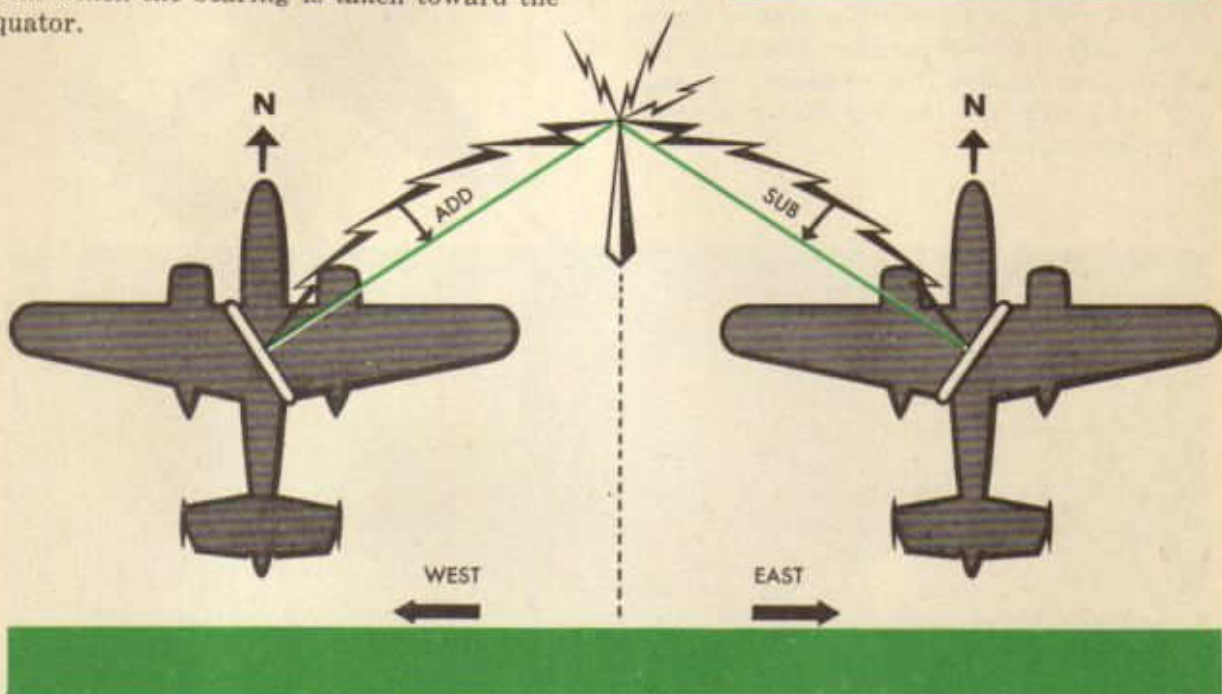

SOUTHERN HEMISPHERE

To aid in the plotting of radio bearings on DF charts, there is printed around each radio range station a special compass rose oriented to the magnetic meridian instead of the true meridian. This saves the navigator one step, in that magnetic bearing instead of true bearing is required. To plot a radio bearing, it is necessary only to draw a line from the range station through the corresponding graduation of the compass rose, using the OUTER (larger) figures. The line so drawn is the desired line of position. The outer circle of figures makes it unnecessary to apply 180° to obtain the bearing of the aircraft from the station.

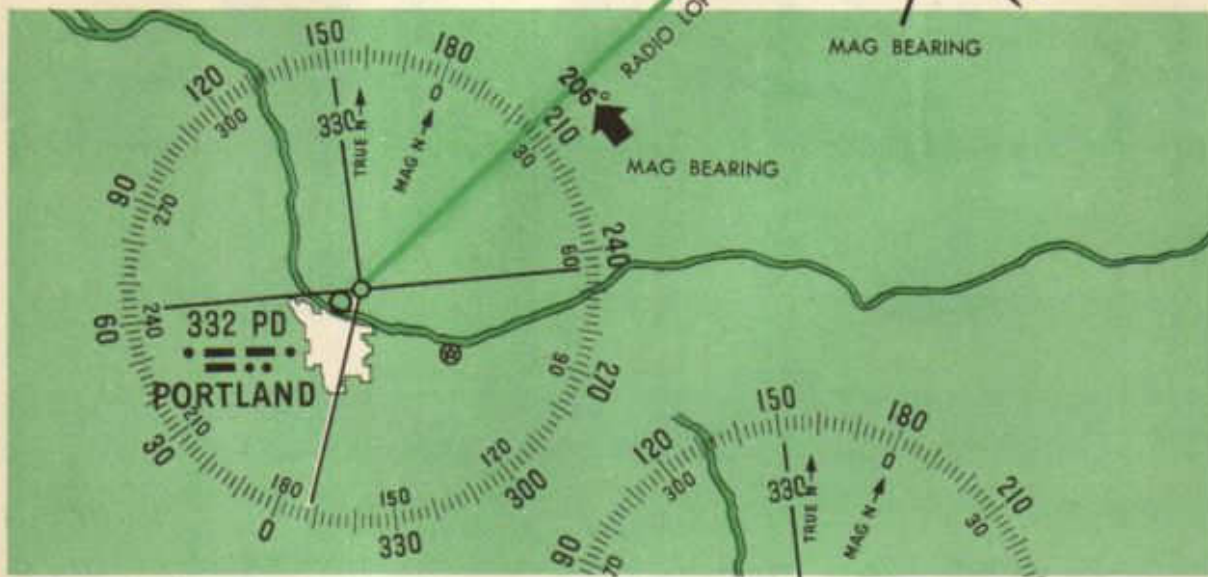
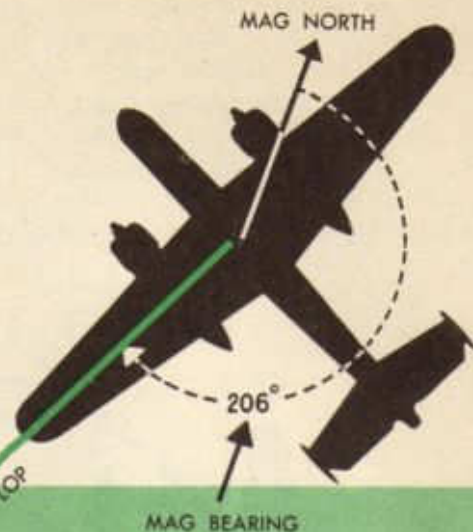

For greatest accuracy on DF charts, corrections may be applied for the convergence of meridians and for the difference of magnetic variation at the aircraft and at the radio station. The correction for convergence of the meridians is 0.6° for each degree of longitude. This correction is sufficiently accurate to use for Lambert charts between 25° and 45° latitude. The correction should, however, decrease to zero at the equator, and increase to 1° at the poles. Remember to add in the north hemisphere if the aircraft is west of the station and to subtract if the aircraft is east. The difference between the magnetic variation at the aircraft and at the

radio station should be added if the variation at the aircraft is smaller westerly or greater easterly than at the radio station; subtracted, if the reverse.

For practical navigation purposes, however, these corrections may be disregarded on DF charts. Ordinarily, bearings are taken on radio stations only a few degrees of longitude, at most, from the aircraft; so the amount of correction is seldom more than two degrees. Thus, for practical purposes, the magnetic rose around a range station may be used to establish lines of position when the aircraft is not too far distant from the transmitter. When several degrees of

longitude separate the aircraft and station, the correction can be avoided by measuring the bearing at the mid-meridian.

Mercator charts, however, present a different problem. The meridians do not converge at the poles, and the parallels of latitude expand as the distance from the equator increases. Thus, great circles, except at the equator, are markedly curved lines; so in actual practice no attempt is made to plot a radio bearing on this chart. Instead, the bearing is plotted as a straight line on the chart as if it had arrived at the aircraft along a rhumb line track. To do this, the angular difference at the aircraft between this rhumb line track and the great circle track is calculated, and the value is applied as a correction to the observed bearing. The application of this correction provides the

angle of the rhumb line. Tables on page 275, TM 1-205, computed on the basis of mid-latitude and difference in longitude, furnish the desired correction factor by inspection. Suppose, by comparison of the dead reckoning position of the aircraft and the actual location of the range station, the mid-latitude and difference in longitude were found to be 30° N and 4° , respectively. By inspecting the table, the amount of the correction is found to be 1° . If the aircraft is east of the station, subtract this correction from the radio bearing; if the aircraft is west, add. The reverse of this is true in the southern hemisphere. During the remainder of this discussion it will be assumed that Mercator correction is to be applied.

Assuming that a radio line of position is to be plotted on a Mercator chart, the follow-

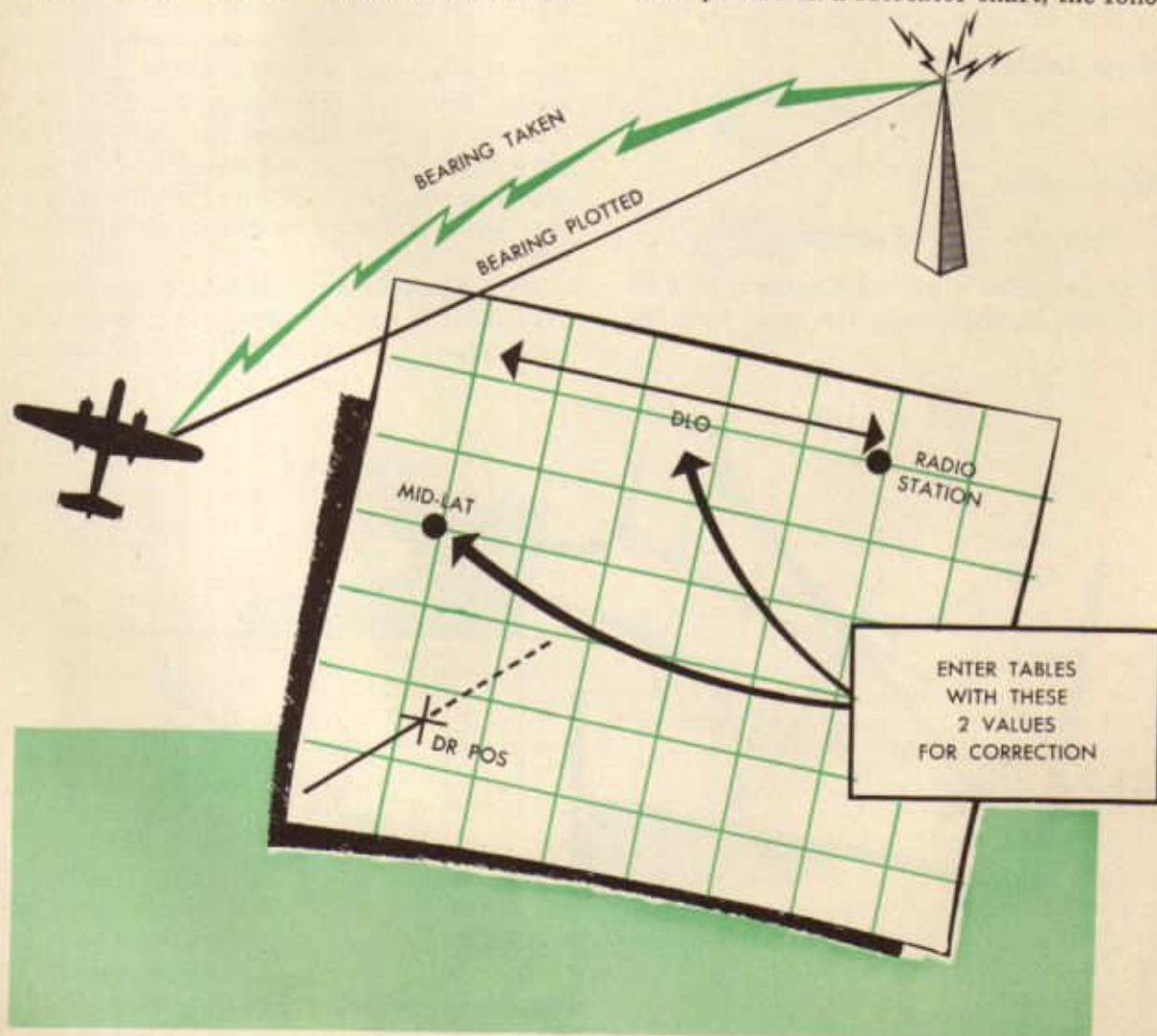

ing summary can be made of data and calculations for obtaining and calculating a radio line of position.

1. Indicated relative bearing, 90° (from azimuth dial)
2. Quadrantal correction, -10° (from graph)
3. Corrected relative bearing, 80° ($90 - 10$)
4. True heading of aircraft, 20° (Calculated from CH)
5. True bearing of station from aircraft, 100° ($80 + 20$)
6. Mercator correction*, -1° (mid-Lat 30°N , DLo 4°)
7. Mercator bearing of station from aircraft, 99° ($100 - 1$)
8. $\pm 180^\circ$
9. Mercator bearing of aircraft from station, 279° (LOP to plot from station)

*North Latitudes:

Aircraft $\frac{\text{East}}{\text{West}}$ of station $\frac{\text{Subtract}}{\text{Add}}$

South Latitudes:

Aircraft $\frac{\text{East}}{\text{West}}$ of station $\frac{\text{Add}}{\text{Subtract}}$

The navigator's log must contain this information in addition to the exact time the

bearing was taken, the range station used plus its frequency, and the compass heading. Most log forms provide room for these notations and calculations.

In the discussion of visual bearing it was decided that two or more lines of position taken at the same time provide a fix. It was also shown that lines of position can be moved to the time of a later bearing in order to ascertain a fix. Since radio bearings are merely extensions of visual lines of position, they may be dealt with in the same manner, resulting in radio bearings and fixes.

Since it is customary to move fixes along the true course (never backward), it follows that bearings which fall parallel or nearly so to the true course should be taken first. These course lines are obtained from stations ahead or behind the aircraft. Lines of position which fall perpendicular or nearly so to the true course are called speed lines, because they give the best indication of the aircraft's speed. Thus, the intersection of these two lines of position taken at the same instant show the relation of the aircraft to its true course as well as its distance from the departure point. In other words, a fix is established.

With the automatic radio it is possible to take radio bearings within a few seconds of each other, preventing the need of moving

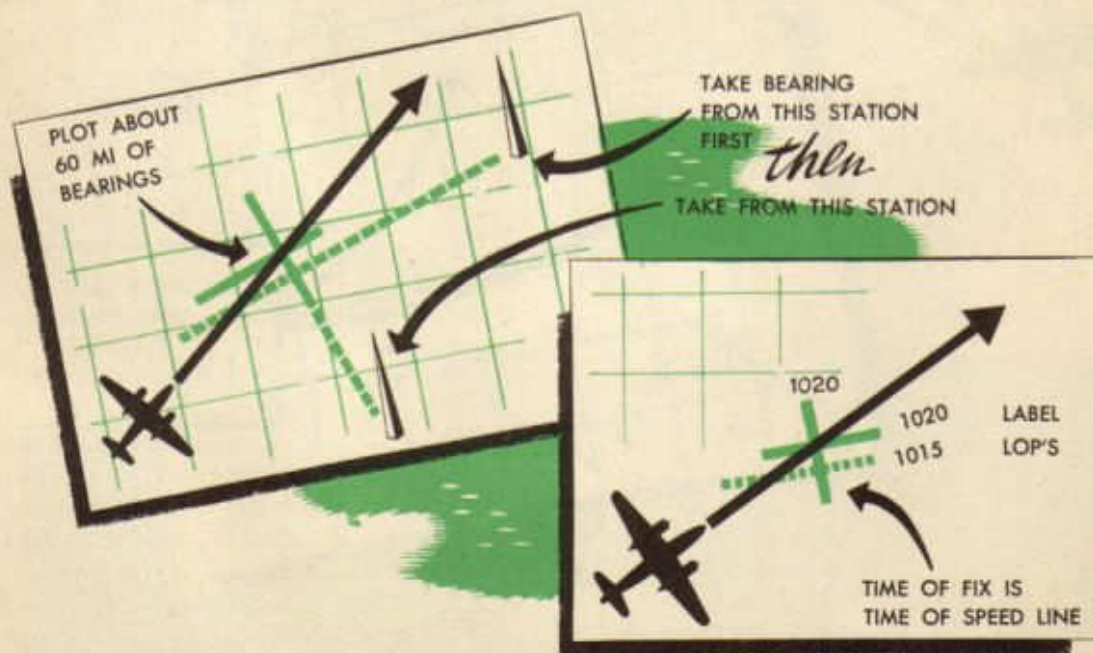

lines of position. However, it must be remembered that the time of the speed line must be taken as the time of the fix.

In order to provide various means of communication, a microphone, an earphone set, and a jackbox are provided at each position in the aircraft. When using the radio compass receiver, the jackbox or selector switch must be placed on COMP and the volume control left in any position, since the microphone is automatically disconnected. The *liaison* position permits the signal from the liaison receiver to be heard in the head-set. When

the microphone button is pushed in, a signal is sent out from the liaison transmitter. The volume control on the headset controls the volume of the signal. The *command* position permits the reception and transmission of command signals between the aircraft and outside stations. Communication is provided between stations inside the aircraft when the selector switch is on *interphone* position. When the message is ended, the microphone button must be released before reception can begin. Emergency calls can be made to all positions inside the aircraft, regardless of the position of the switches at the receiving jackboxes, by *holding* the selector switch on CALL and depressing the microphone button while the message is sent.



With these various positions of the selector switch, the following conditions could exist at the same time. The pilot could listen to the command receiver, the radio operator could send a signal from the liaison transmitter, the navigator could take a bearing with the radio compass receiver, and two gunners could hold a conversation over the interphone system. If the bombardier suddenly located the target, he could put the selector switch in CALL position, depress the microphone button, and talk to all stations inside the aircraft.

Additional Radio Aids

A well-known method of giving radio navigational aid is the directional-transmitter system used in radio range stations. Radio ranges, located throughout the United States, Canada, and Alaska, give aircraft clearly defined, radio-marked "skyways."



The range stations send out four beams of A and N signals. These beams may be sent in any desired direction, but usually they are transmitted along the center line of certain civil airways. The ranges provide voice communication between the ground and the aircraft, weather reports, and traffic instructions to pilots.

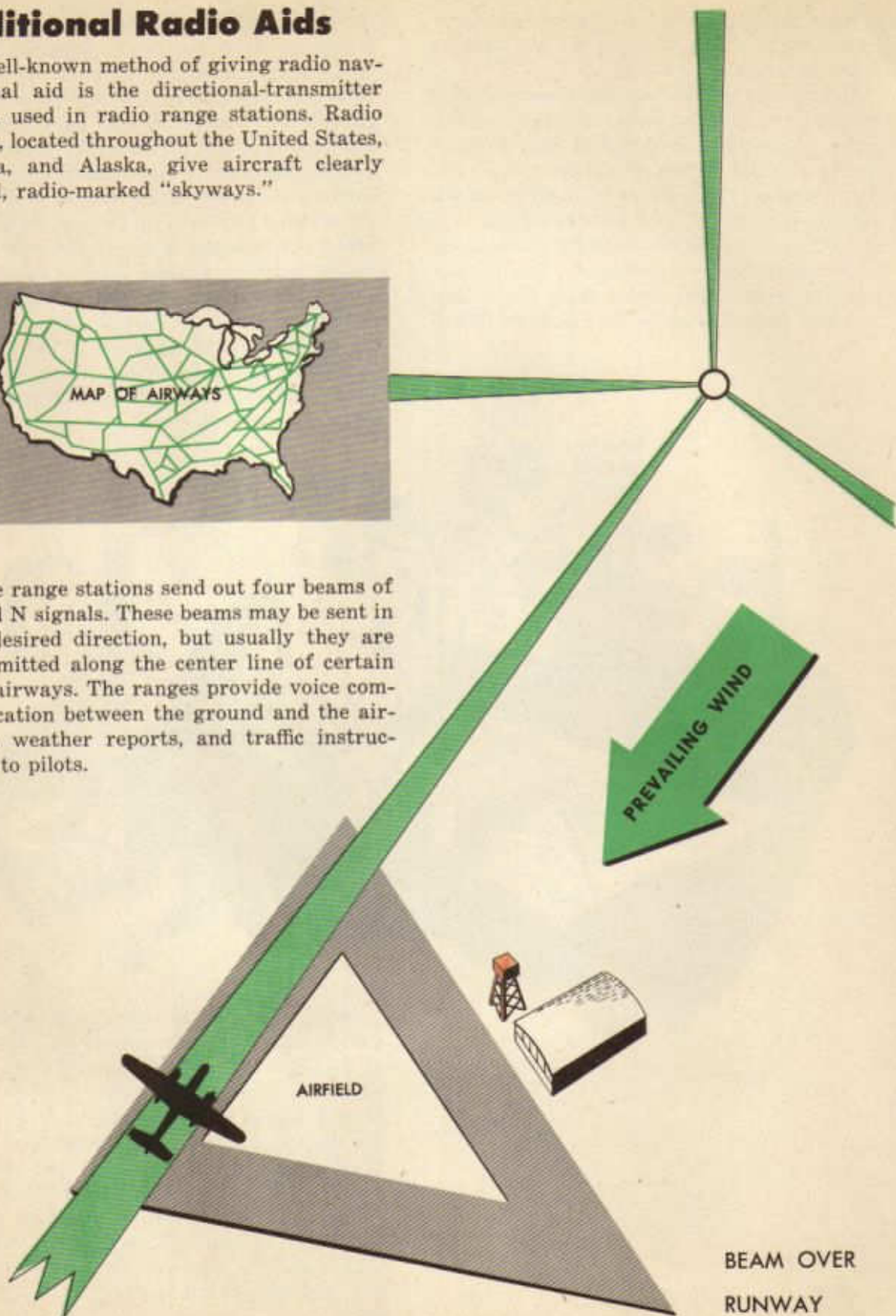

Navigators also use receiving apparatus of directional sensing character. Such an apparatus may be one of the following: a radio direction finder, a D/F loop receiver, or a radio compass. Such equipment makes it possible to establish a relative bearing on any type of radio transmitter. Ground direction finders and aircraft direction finders are examples of the practical adaptation of this principle.

In general, ground direction finders make it possible to get a directional indication or bearing on an aircraft transmitter. Two or more of these stations, operating together, can locate an aircraft by two or more lines of position. The resultant solution of position can be radioed to the aircraft.

A more useful method is to carry the direction finder in the aircraft. It enables the navigator to take and plot bearings on any ground station within his range. This system

can be used with any type of ground transmitter.

Strictly speaking, neither radio transmitter nor receiver is "directional." This is purely a function of the antenna. Ordinary antennas transmit or receive radio energy with about the same efficiency and are considered to be nondirectional. A closed loop or a coil of wire, however, makes an antenna which is highly directional for either transmission or reception. An alternating current passed through a loop sets up an electromagnetic field of force which is not of equal strength in all directions. It is greatest in a plane parallel to the loop and decreases nearly to zero in a plane at right angles to the loop.

If this alternating current is of radio frequency, the loop is acting as a directional antenna for the transmission of a radio field or voice. The action of a closed loop used as a receiving antenna is almost the opposite; therefore the reception is directional. When the plane of the loop is parallel to the direction of the wave the induced voltage is at a maximum. It is at a minimum when the plane of the loop is at right angles to the direction of the incoming wave.

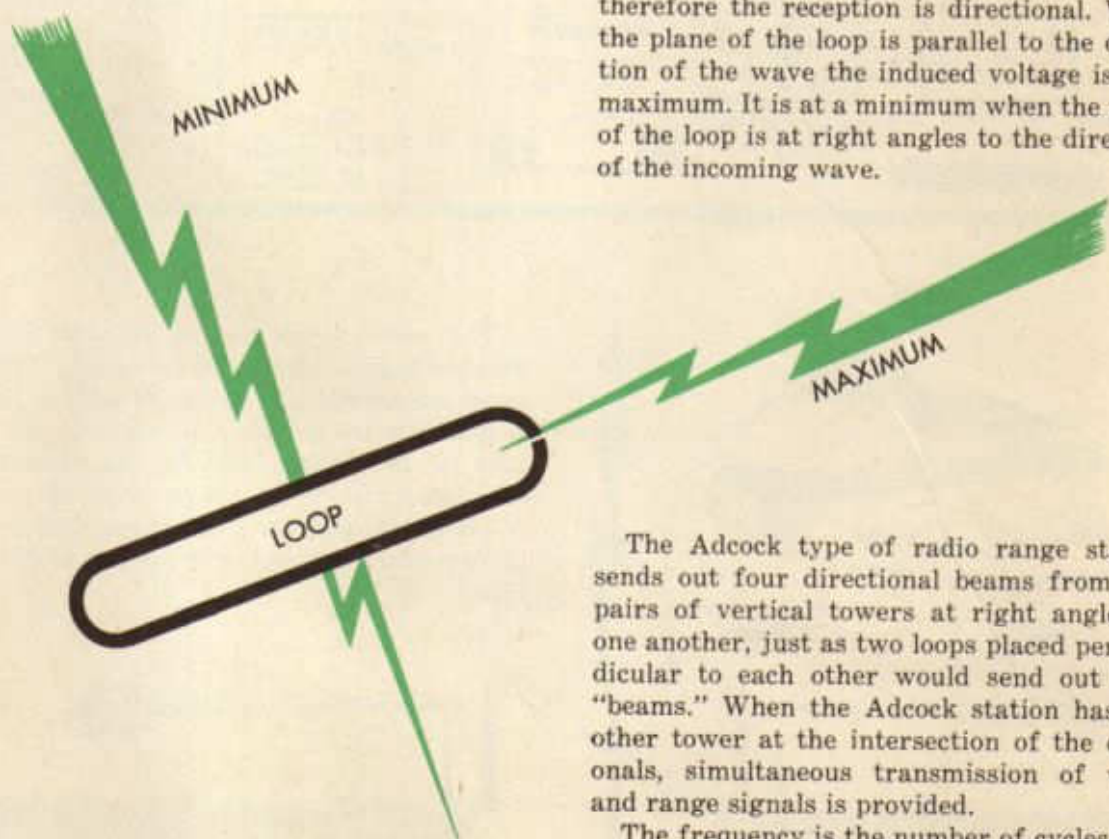

The Adcock type of radio range station sends out four directional beams from two pairs of vertical towers at right angles to one another, just as two loops placed perpendicular to each other would send out four "beams." When the Adcock station has another tower at the intersection of the diagonals, simultaneous transmission of voice and range signals is provided.

The frequency is the number of cycles that occur per second; therefore the greater the frequency the shorter the wave length. Frequencies below 500 kilocycles are used in some army and marine services and radio

range transmissions; frequencies between 500 and 1,500 kilocycles are used for standard broadcasting; and frequencies above 1,500 kilocycles are used for many types of

operation, including amateur, police, general commercial, Army radio communication, Army Air Forces communication, and Navy communication.

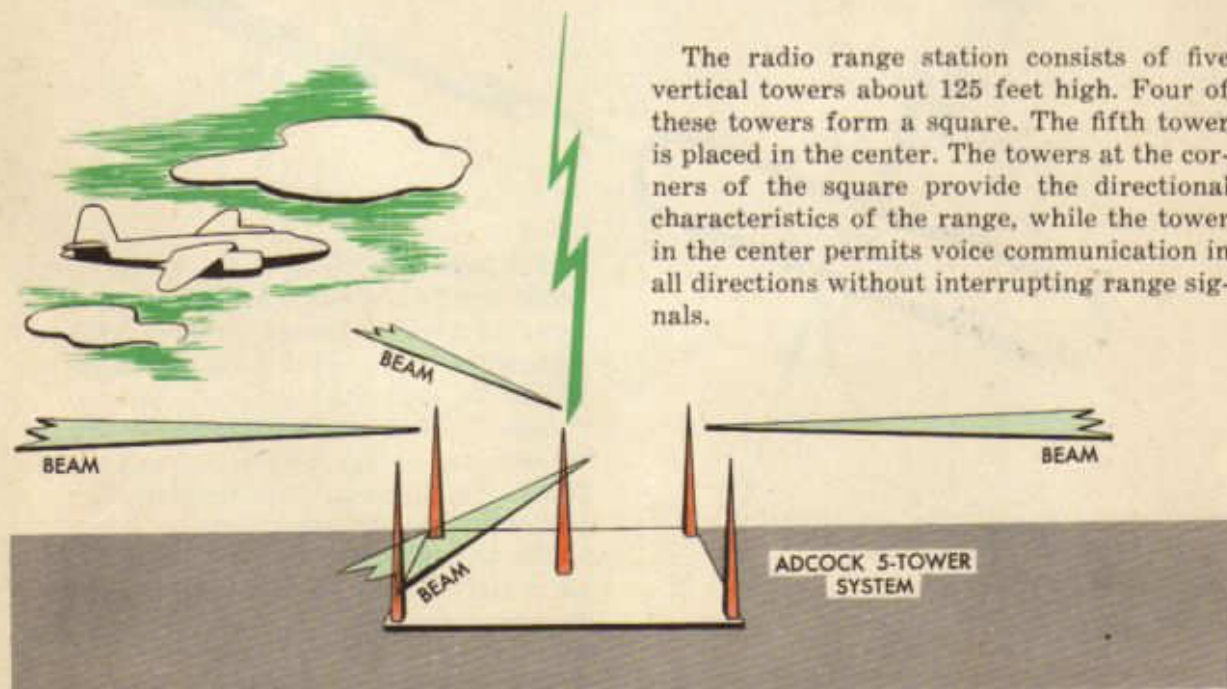
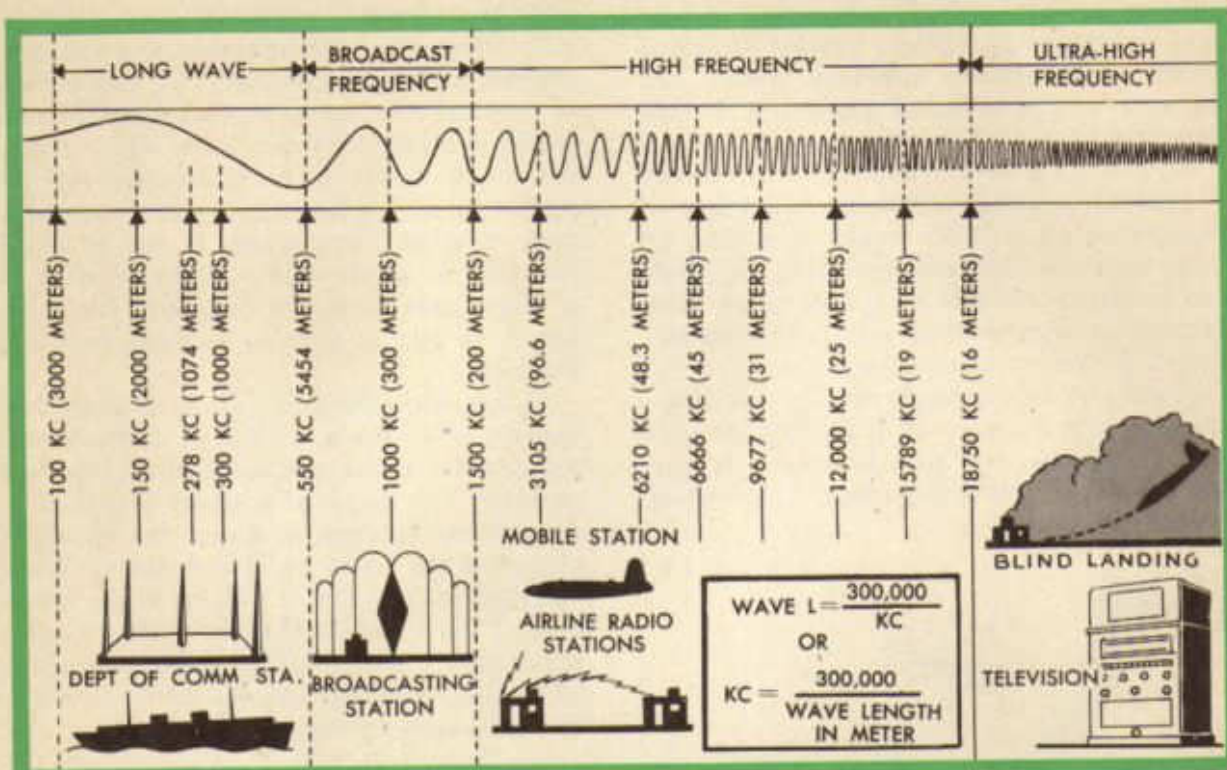

The four vertical towers forming the square provide two transmitting antennas at right angles to one another for sending out the directional signals. A single transmitter feeds a coded signal to each of these two antennas. One antenna emits the signal N (— ·) while the other produces A (· —). These signals are so timed that they interlock perfectly. In other words, as the dah dit of the N is being sent on one antenna while the dit dah of the A is being sent on the other antenna: the dit fits exactly into the interval between the two parts of the N. The remaining dah of the A fits exactly in the interval between the last and first parts of succeeding N signals. Thus, if the A and N signals are received with equal strength, it is impossible to hear either the A as such or the N as such. Instead, the two signals are blended into the continuous hum of the "on-course" signal. The signal means the aircraft is on the radio beam.

Beam widths are usually 3° wide but vary somewhat according to the radio range station. There is also indicated a bisignal zone

in which not only an undertone of the beam can be heard but also the "A" or the "N" tone will predominate. When passing out of the bisignal zone, the "hum" or beam tone is very loud near the beam with the "A" or "N" tone much weaker. Going away from the beam, the "hum" becomes weaker until the "A" or the "N" off course sectors are reached.

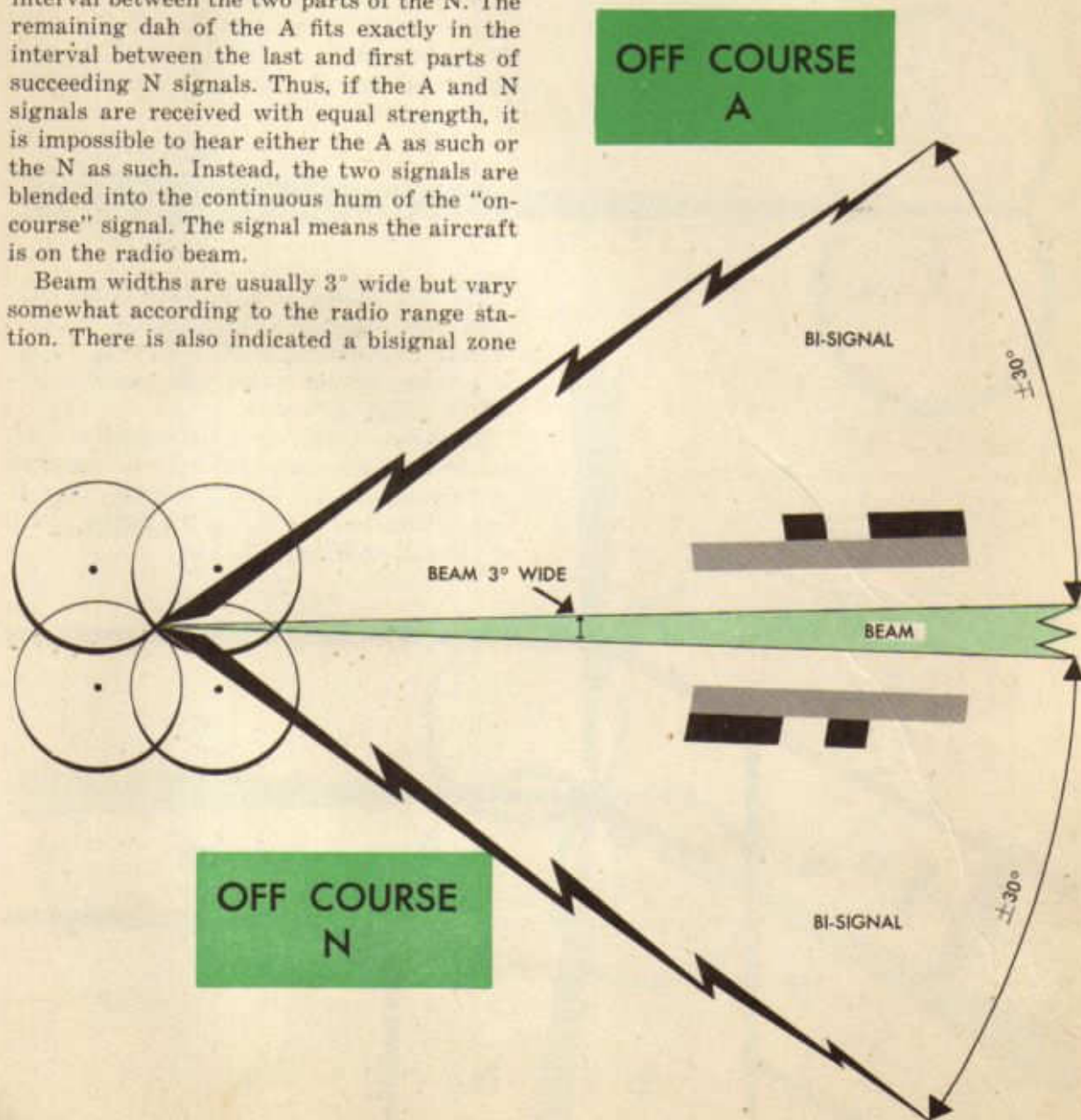

Not only do these radio-transmitting towers transmit an "A" signal or an "N" signal but at frequent intervals (approximately every 30 seconds), first on the "N" towers and then on the "A" towers, the call letter or letters are transmitted. The strength of the call letters varies exactly with the strength of the "A's" or the "N's" which are being received. The strength at which these identification letters are received identifies

another point on the pattern which is known as the twilight band. This is the border between the bisignal and the beam. In the "N" bisignal zone, the first station identification signal heard is the one broadcast by the "N" towers. The second station identification signal transmitted by the "A" towers is much weaker. Theoretically, when approaching the beam, the identification signals become more and more of the same strength. Just before the "A" and the "N" identification signals become the same strength, the twilight band is reached. The ear is not acoustically sensitive enough to detect this change at exactly the right instant, so the extent of the twilight band depends mostly on the sharpness of the ear.

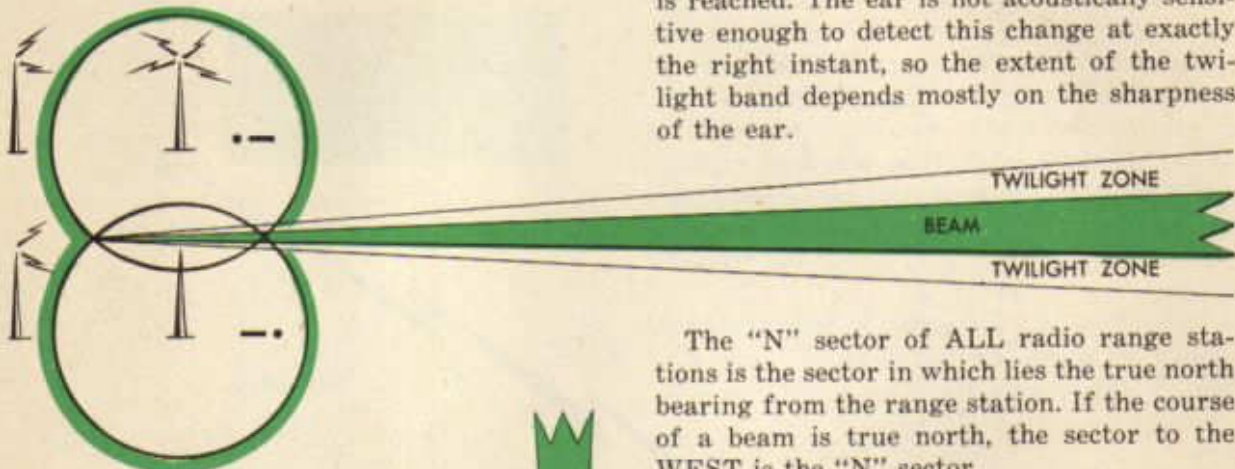

The "N" sector of ALL radio range stations is the sector in which lies the true north bearing from the range station. If the course of a beam is true north, the sector to the WEST is the "N" sector.

Ranges or beams of a radio station need not be at right angles but may be deflected to correspond to the air routes. This is accomplished by increasing the power in one or more of the quadrants.

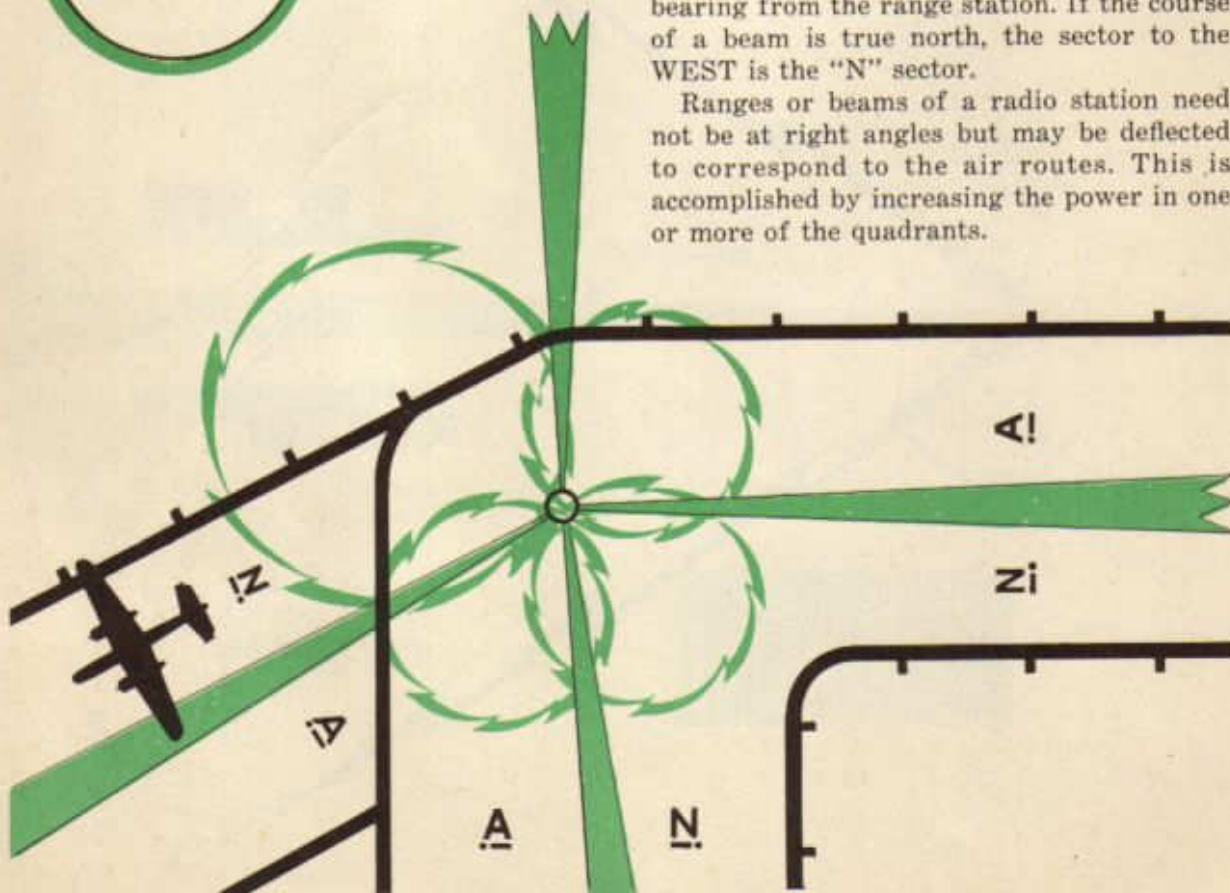

Above the radio range station is a space in which there is no signal. This is known as the *cone of silence*, and, as the name implies, it is an inverted cone with the apex at the beam station. If the aircraft antenna has a vertical component, and the aircraft is on the beam approaching the transmitting station, the beam signal increases in volume as the distance to the station decreases. This increase will continue at a constant rate until just before the cone of silence is reached, at which time there will be noticed a rapid build-up of signal strength and then silence. After passing through the cone of silence, the very loud signal is again heard, rapidly diminishing to a constant rate of decrease in volume as the distance is increased away

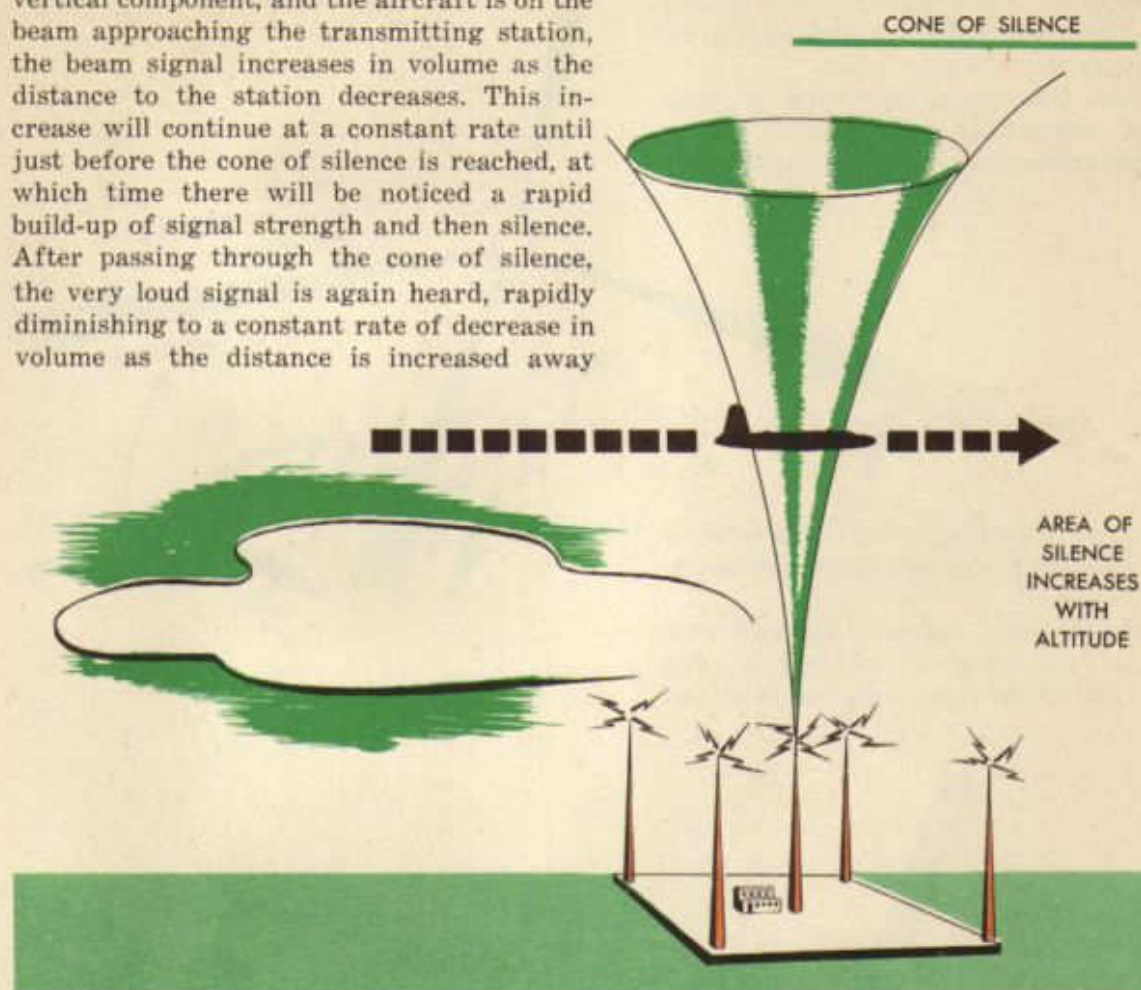

from the station. In flying the beam, the beam signals may possibly fade, and when this occurs, the navigator may believe that the cone of silence has been passed. There is no need for this belief because in order to pass through the cone of silence, there must occur the rapid build-up, the silence, the surge of volume and then the diminishing of the beam signal. If the navigator observes closely for these characteristics, he will have no difficulty in locating the true cone of silence.

The range station which gives the true cone of silence, that is, vertically above the beam station, is one in which the "A" and

the "N" quadrants are 90° apart. Where the "A" and "N" sectors are unequal, the cone of silence will be tilted from the vertical. Peculiarities exist at some stations where no true cone of silence will be obtained.

Radio ranges have other problems, among which are severe *static* disturbances. Low frequency wave bands are often troubled with static during thunderstorms, rain, and snow.

Certain peculiarities are found when flying the radio beam. The on-course signal is heard when the A and N signals are received with equal intensity. But mountainous terrain sometimes absorbs part of the radio

waves normally received in the bisignal zones; thus there is a chance that both signals may be received with equal intensity. When this occurs, it results in one or more other beams which are not the true beam. These *multiple beams* take the form of long ellipses. They are usually found in the bisignal zones near the true beam.

Also, the true beam may *bend or shift* direction, because of metallic ores in the earth, mountainous terrain, or large bodies

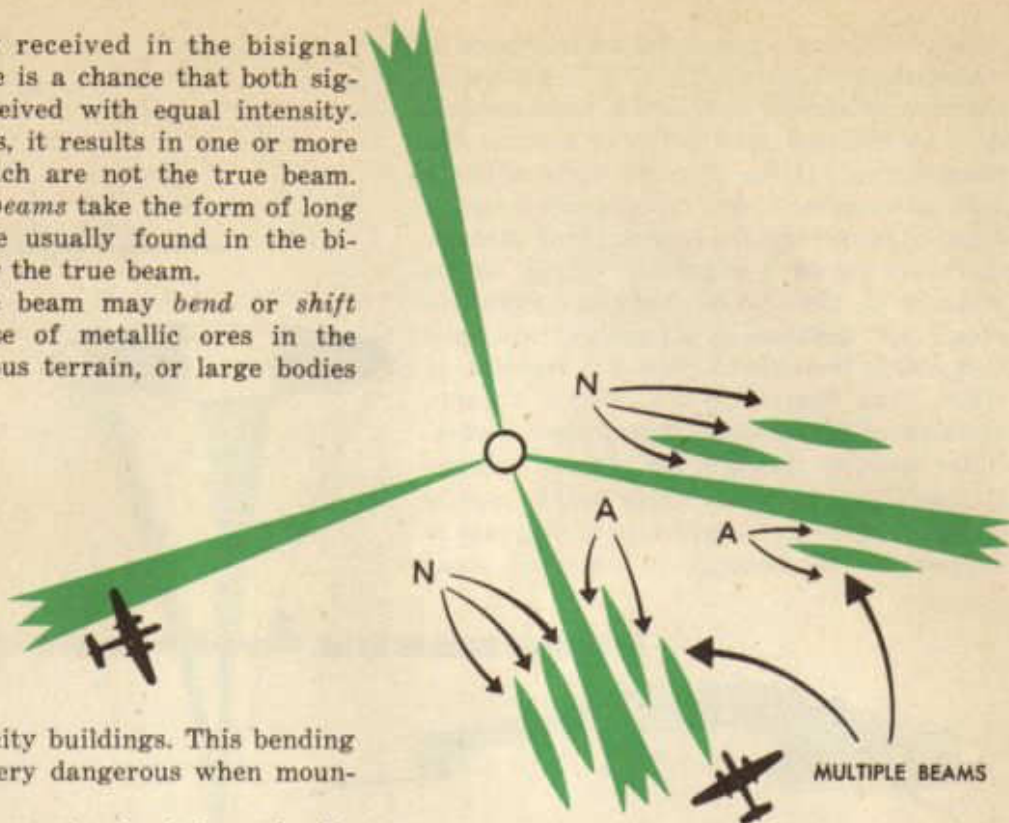

of metals, as in city buildings. This bending of the beam is very dangerous when mountains are near.

Sometimes range signals *fade and skip* because of the peculiar reactions of two waves. Low frequency stations send out

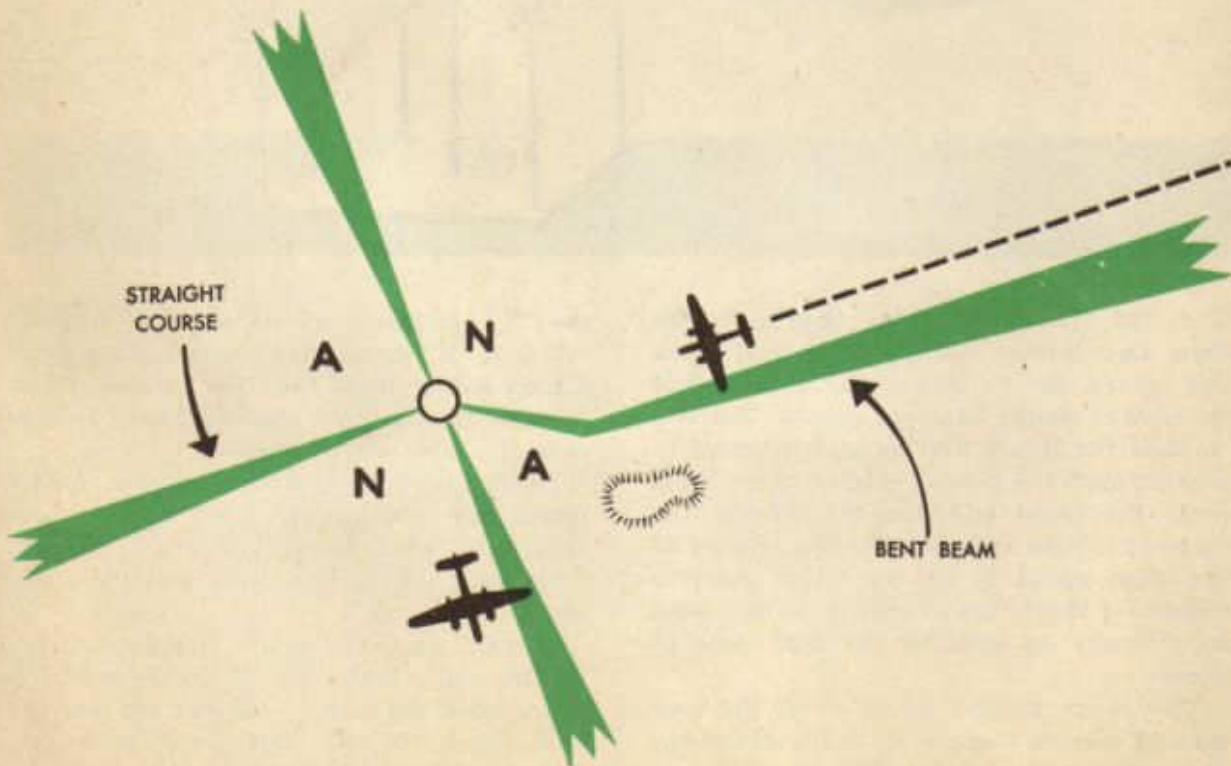

ground waves and sky waves. Normally signals from such stations travel in the ground wave which travels nearly horizontal to the earth. The sky wave ordinarily travels sharply away from the earth's surface. But, when the sky wave is reflected earthward, the signals fluctuate in volume or shift from their correct position. This effect most often takes place during morning and evening twilight.

Some range stations have *swinging beams*. The on-course signal moves from side to side,

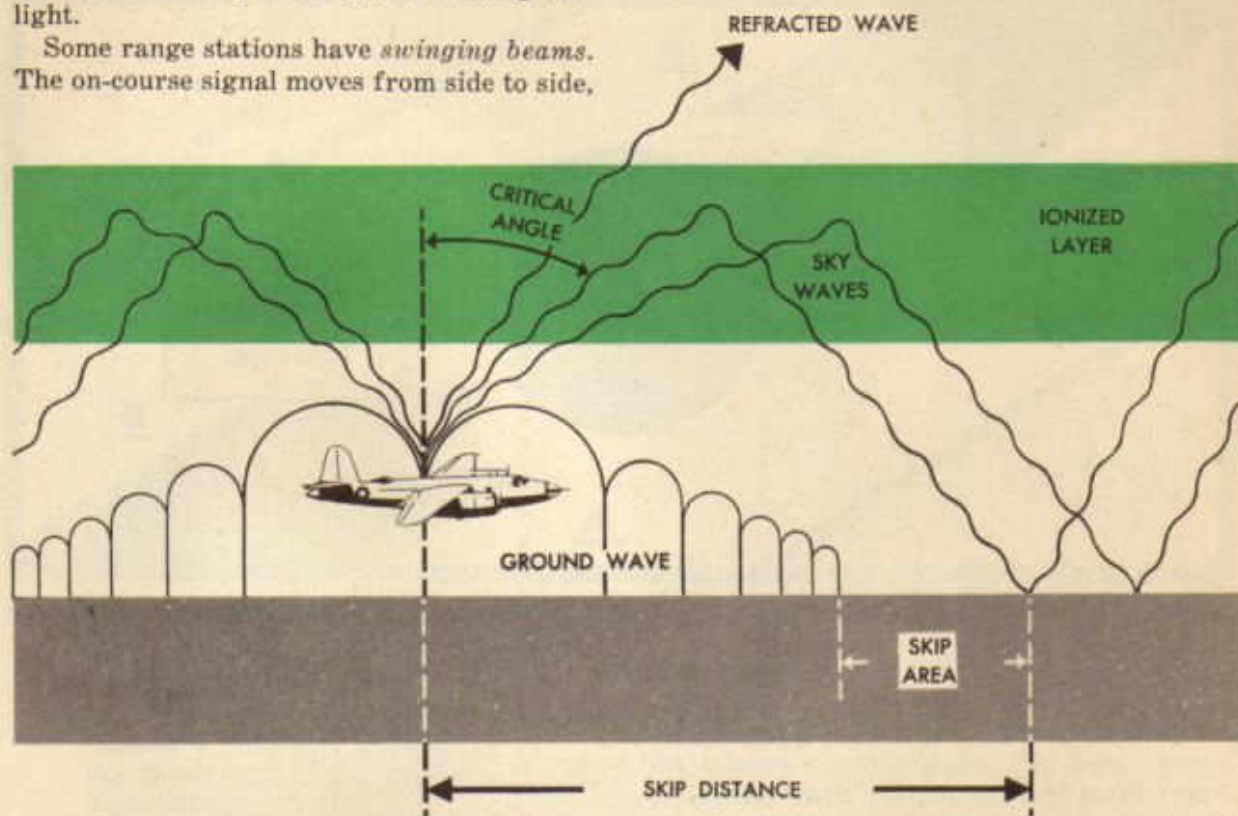

making it almost impossible to get a steady compass heading.

In an effort to solve some of these radio range problems, the M, Z, and Fan-type marker beacons have been devised. When an aircraft passes into the cone of silence above a range station, the position of the aircraft is established; in other words, a "fix" is obtained. Other radio navigation aids, such as marker beacons, aid in obtaining fixes at the cone of silence as well as at other points along the airways.

A class "M" marker beacon is a low-powered, nondirectional radio station which transmits a characteristic signal, such as "R" (·—·) once every few seconds. Class "M" marker beacons are normally equipped

for voice communication with aircraft. The range of these marker beacons is from 3 to 10 miles, depending on the weather as well as the type and condition of receiving equipment. M-type marker beacons are usually placed at the intersection of two range courses, thus indicating when to tune to the next station. In such cases the characteristic signals are transmitted on the same frequencies as the adjacent radio ranges so that they can be heard if the receiver is tuned to either range. Marker beacons may also be placed on or near some obstruction, such as a radio tower, or at some particular point along the airway. An M-type beacon does not operate continuously, but it is turned on when the local ceiling is more than one-tenth overcast

or the visibility is less than five miles, or at any time on request.

Class "Z" markers are located at most radio range stations and give a positive indication at the time a cone of silence should be received. The Z-type marker has an antenna

M-TYPE MARKER BEACON

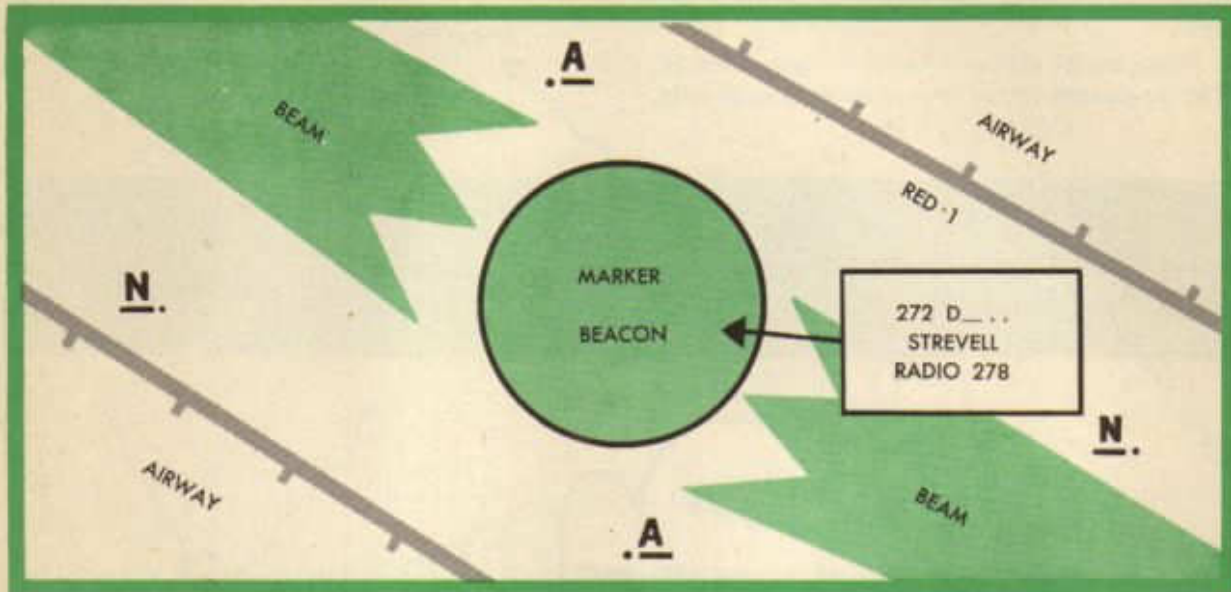

which produces a high intensity signal in a space shaped like a tear-drop immediately above the station. Owing to the high frequency used (75 megacycles), a special receiver must be installed for their reception. Z-type markers furnish a position check both visually and aurally; the first by means of a small amber light on the instrument panel and, second, by a steady high-pitched signal which reaches maximum intensity over the station. Like the cone of silence, the duration of the Z-type marker indication increases with increasing flight altitude.

The "FM" or *fan-type* marker beacons are the ultra-high frequency type. This type of marker beacon has a type of antenna which

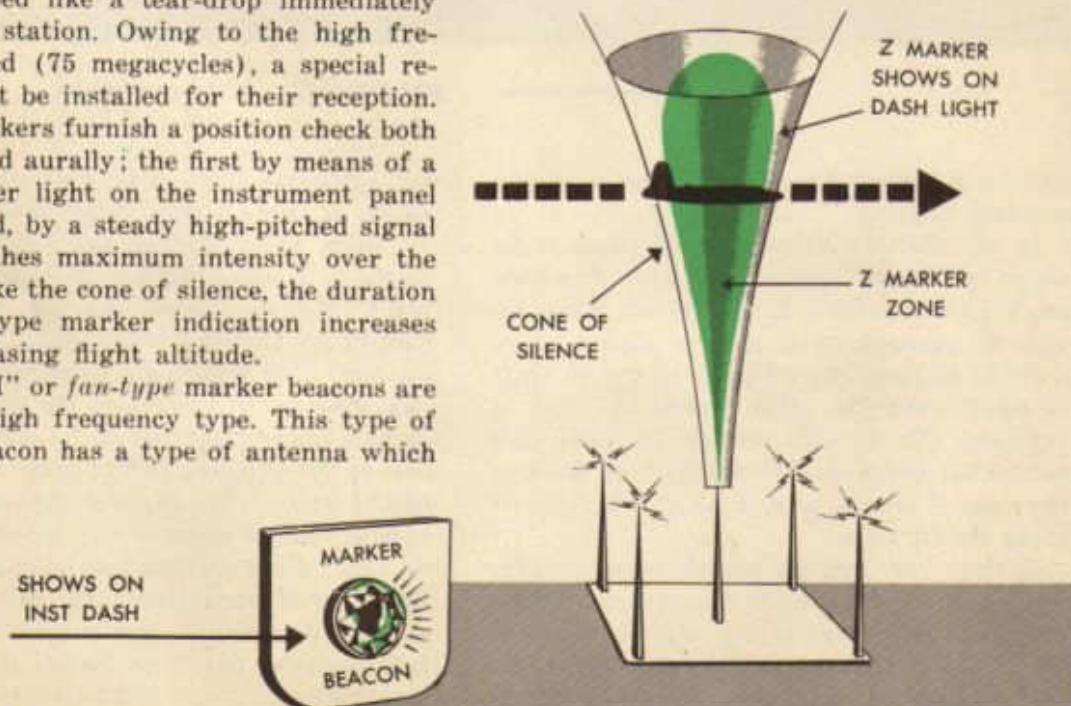

produces a high intensity signal in a space immediately above the station, roughly corresponding to a thick fan. This fan is placed so that its plane is at right angles to the airway. These beacons operate on a frequency of 75 megacycles, and they have no facilities for voice communication. From one to four fan markers may be located around any given range station, usually at a distance of

about 20 miles. The markers around a given radio range station are identified by a succession of single dashes, or by groups of two, three, or four dashes. The single-dash identification is always assigned to a course directly true north from a station, or to the first course in a clockwise direction; therefore the groups of two, three, or four dashes are assigned respectively to the second, third, and fourth courses of the station, proceeding clockwise from the single-dash beacon.

The signal of a fan marker beacon, then, identifies a particular course of a range in addition to a position along that course; it

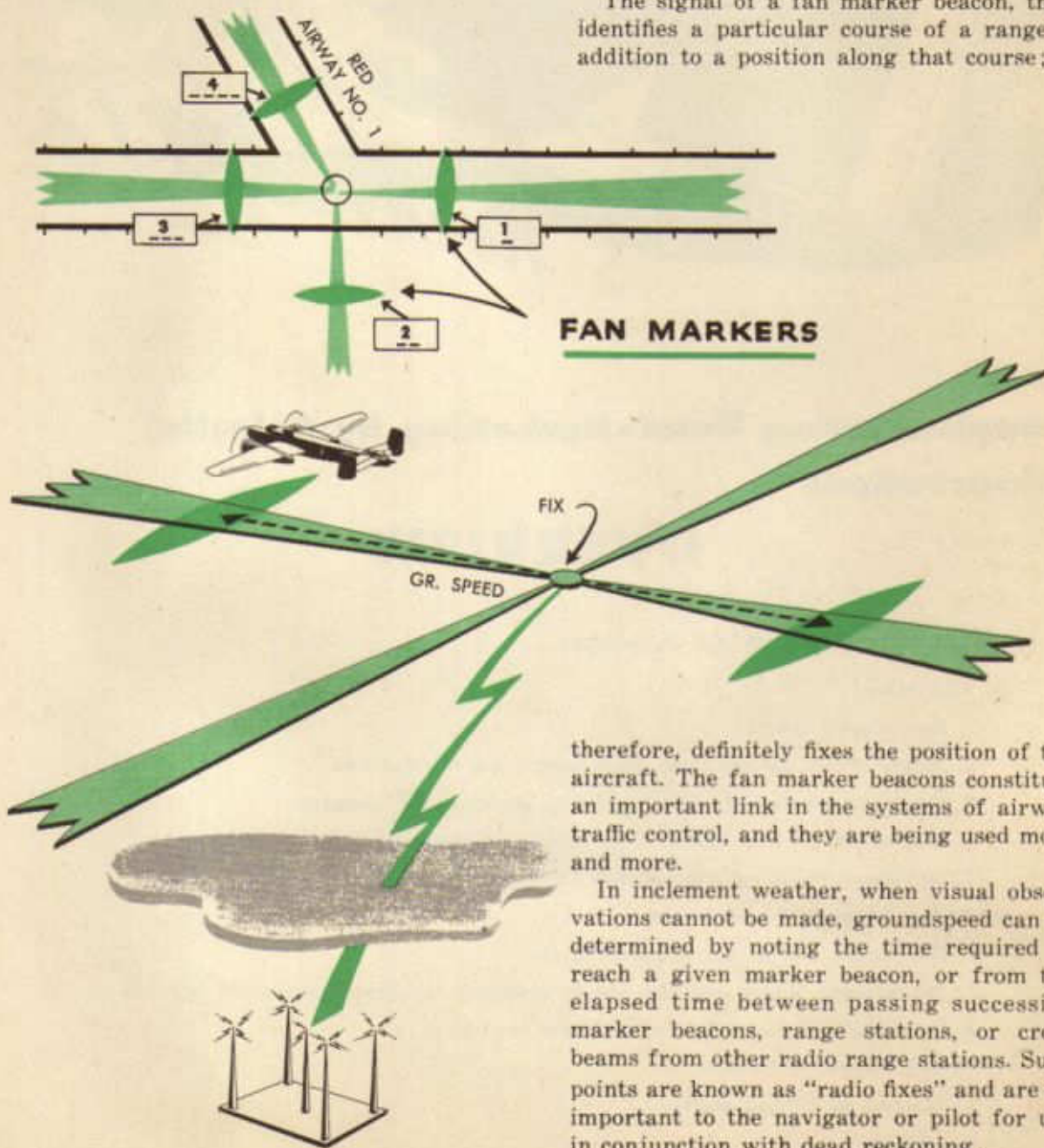

FAN MARKERS

therefore, definitely fixes the position of the aircraft. The fan marker beacons constitute an important link in the systems of airway traffic control, and they are being used more and more.

In inclement weather, when visual observations cannot be made, groundspeed can be determined by noting the time required to reach a given marker beacon, or from the elapsed time between passing successive marker beacons, range stations, or cross beams from other radio range stations. Such points are known as "radio fixes" and are all important to the navigator or pilot for use in conjunction with dead reckoning.



Supplementing Dead-Reckoning by Celestial Observations

OVERVIEW

I. OBTAINING THE LINE OF POSITION

A. Basic ideas

1. The celestial sphere
2. Minute of arc on any great circle equals one nautical mile
3. Ideas of horizon, HO, azimuth, plotting position, and intercept
4. Location of celestial bodies: LHA, azimuth, declination
5. Definition of and relation between CWT and GCT, LHA and GHA

B. Solving for azimuth and intercept

1. The sextant and its use in obtaining Ho
2. The Almanac Tables and their use in obtaining arguments for entering HO 218
3. Using HO 218 for finding azimuth and intercept

C. Plotting the line of position

1. Assumed or plotting position
2. Azimuth

3. Intercept
 4. Short-cuts for quick, accurate plotting
- D. Classifying lines of position
1. Speed lines
 2. Course lines
 3. Other uses

II. USING LINES OF POSITION IN SIMPLE PROBLEMS

- A. As a check
1. Sextant check by HO 218
 2. Latitude by Polaris
- B. The landfall
1. General technique of the landfall
 2. Landfall procedure and log

III. SOME OF THE THEORY BEHIND THE LINE OF POSITION

- A. The celestial sphere
- B. The heavenly bodies
1. Identification
 2. Motions
- C. Time and the chronometer

IV. USING THE LINE OF POSITION IN MORE COMPLEX PROBLEMS

- A. Latitude by meridional altitude
- B. Compass correction
1. Instruments: Astro-compass, driftmeter, shadow-pin
 2. Air swinging by celestial azimuth
 3. On-course deviation
- C. Pre-computation
1. Methods of solution
 2. Applications
- D. Position-finding: the fix
1. Obtaining the fix
 2. Aids to obtaining the fix
 3. Interpretation of the fix
 4. The fix mission and log

OBTAINING THE LINE OF POSITION

Basic Ideas

Celestial observations result in obtaining lines of position which may be used either singly or in conjunction with others as fixes. However used, celestial lines of position supplement and confirm the results obtained from dead reckoning.

For navigational purposes the universe is regarded as a hollow sphere, traditionally called the *celestial sphere*, with the earth at the center and with a radius of infinite length. The stars, sun, moon, and planets are projected onto the celestial sphere so that a line from any body to the center of the earth represents the radius of the celestial sphere. This concept is far from fact since actually the distance of the stars from the earth is a measurable and varying quantity, but this does not affect the validity for navigational purposes of the trigonometric solutions which are based on the infinite distance of the stars and planets.

actually move perceptibly, it appears to move by reason of the earth's revolution in its orbit. Therefore, the mathematical computations involved when observations are taken on the sun, planets, and moon differ somewhat from those when the stars are observed.

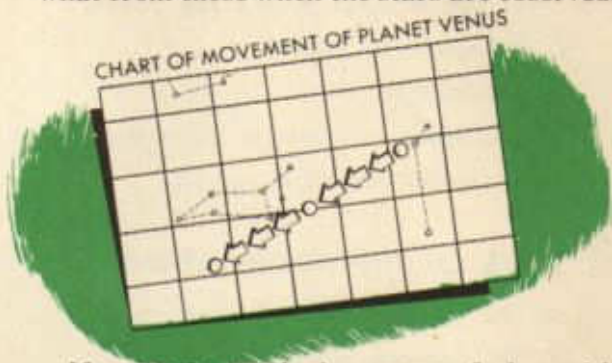

If a navigator had a range finder with which he could calculate the distance from a terrestrial landmark, he would be able to obtain a fix when two or more landmarks were visible by striking arcs from the landmarks on his chart with radii equal to the distance of the aircraft from the landmarks. The intersection of the arcs would constitute a fix. Basically, a celestial fix is obtained in the same way.



The stars are regarded as fixed pinpoints of light which do not change position relative to each other. This is also contrary to fact, but the movement of the stars is not distinguishable to an earth-bound observer and does not affect the mathematical calculations used in navigation. However, the actual motion of the planets and moon is apparent to an observer and, while the sun does not

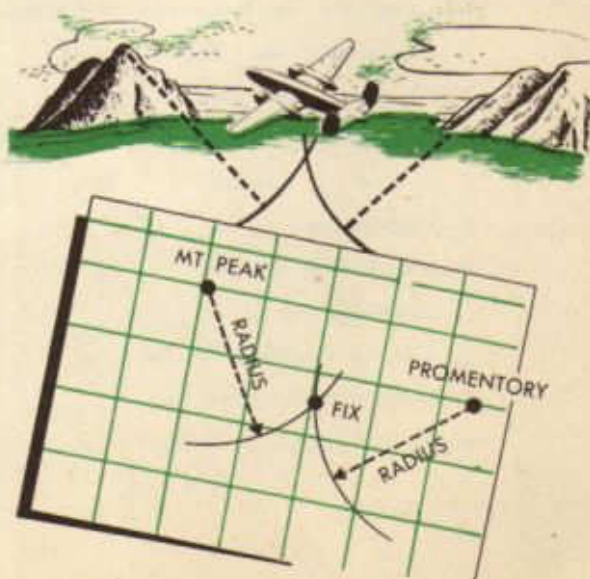

A line from the body to the center of the earth will intersect the earth's surface at some point vertically beneath the body. This point on the earth is called the *subpoint* of the body. The subpoint of the body corresponds to the terrestrial landmarks in the

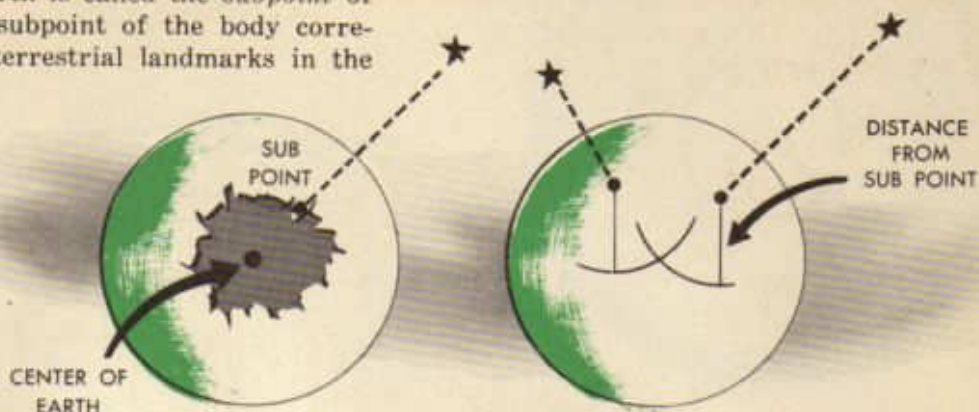

illustration previously given, so that if the navigator can determine the distance from his position to two or more subpoints, he can obtain a fix in a similar manner.

To comprehend the method by which the navigator calculates his distance to the subpoint, several basic definitions and concepts must be understood.

1. Zenith and nadir

That point on the celestial sphere directly over the head of an observer is called the *zenith* and the point directly below him the *nadir*. A line joining zenith and nadir, called the zenith-nadir axis, will pass through the observer's position and the center of the earth as shown by the diagram.

In this and the following diagrams, the outer figure represents the celestial sphere

and the inner one, of course, the earth.

2. Horizon

The simplest conception of horizon is the line which appears to an observer at sea to mark the intersection of earth and sky. This horizon, called the *visible horizon*, varies with the elevation of the observer above the earth and, therefore, is not of much use to the aerial navigator, who must make celestial observations at all altitudes. The diagram shows how the visible horizon varies with altitude.

The *sensible* or *bubble* horizon is a plane tangent to the earth at the observer's position and perpendicular to the zenith-nadir axis.

The visible horizon of an observer whose eye is at ground level will coincide with the

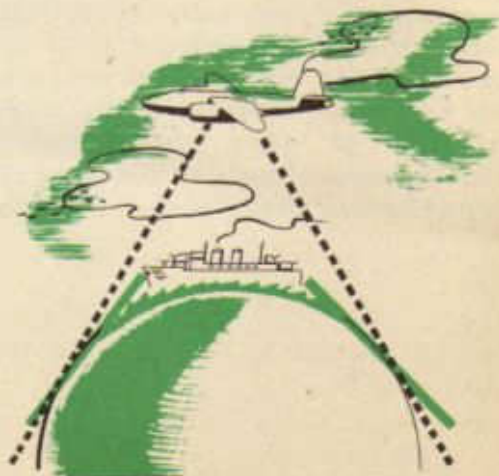
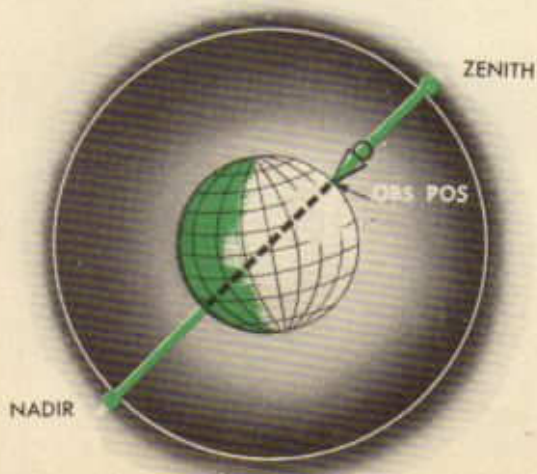

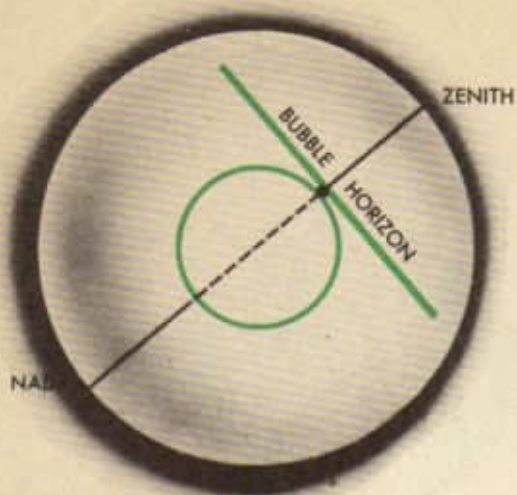

bubble horizon. The spirit level of an aircraft sextant is aligned in a plane parallel to the bubble horizon and enables the navigator to determine the angular distance of bodies above this plane.

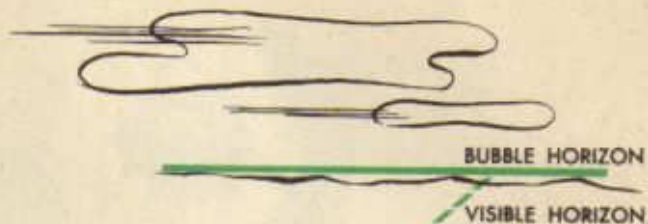

An observer will be able to see all points on the celestial sphere 90° away from his zenith. Thus, if the equator could be projected onto the celestial sphere, an observer at the north pole could see any body on or above this imaginary line. A and B are two bodies on the imaginary line representing the extension of the equator to the celestial sphere. Observers at either P or S (north and south poles) will be able to view A or B. This line on the celestial sphere which is everywhere 90° away from the zenith is called the celestial horizon. The plane of the celestial horizon passes through the center of

the earth and since both are perpendicular to the zenith-nadir axis the celestial horizon and bubble horizon are parallel.

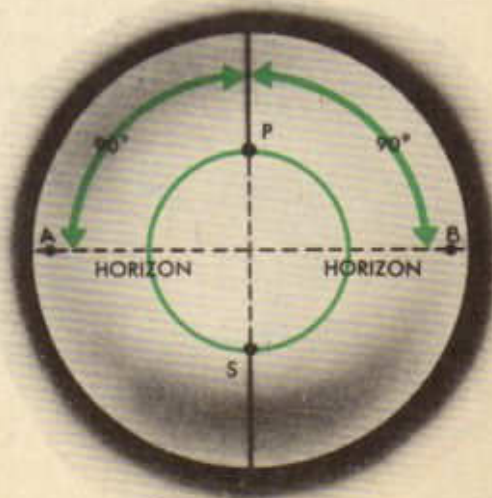

Because of the infinite distance of the stars from the earth, the sensible horizon and celestial horizons appear to intersect on the celestial sphere at the same point in the same manner that the rails of a railroad track appear to converge. For navigational pur-

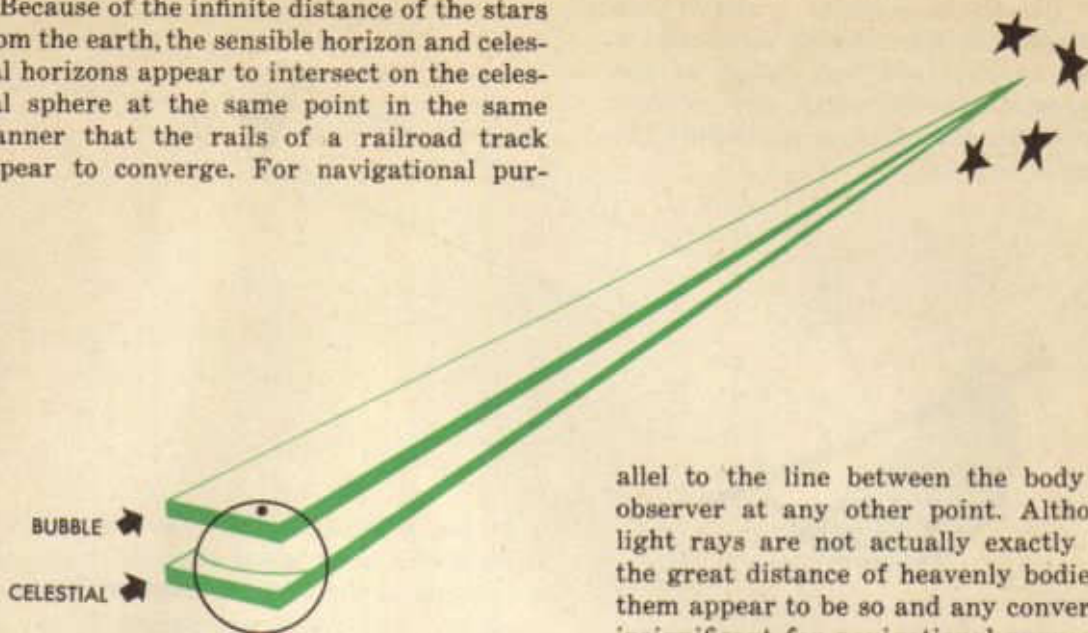

allel to the line between the body and an observer at any other point. Although the light rays are not actually exactly parallel, the great distance of heavenly bodies makes them appear to be so and any convergence is insignificant for navigational purposes.

poses the sensible and celestial horizons are assumed to be coincident, the length of the earth's radius which separates the two horizons being a negligible factor when projected onto the celestial sphere.

From the foregoing it is apparent that it is immaterial whether the angular distance

With one important exception, the rays of light from any heavenly body appear to be parallel; that is, a line between an observer at any point on the earth and a body is par-

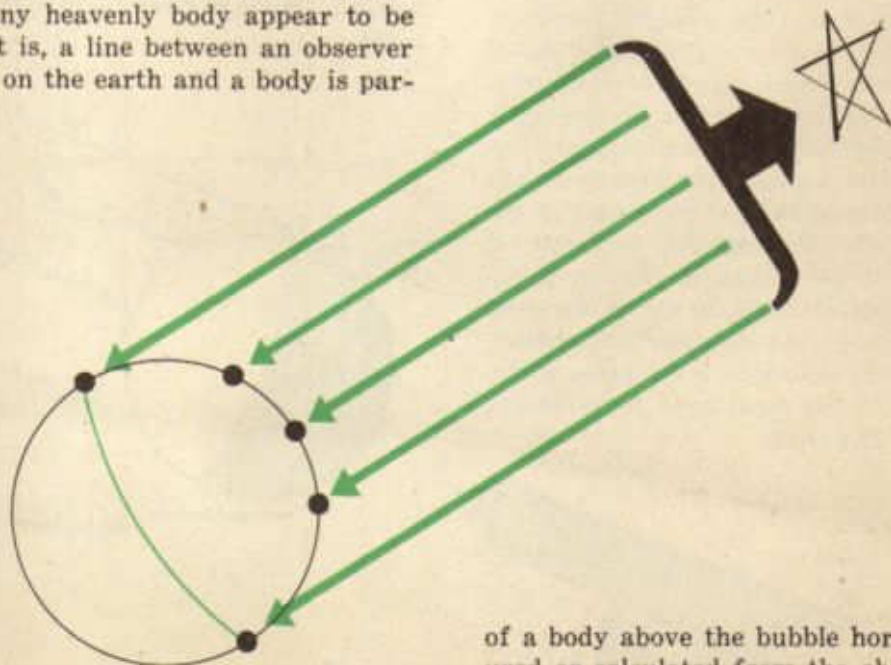

of a body above the bubble horizon is measured or calculated from the observer's position or from the center of the earth using the celestial horizon as the reference plane. In fact, all celestial computations assume that the eye of the observer is at the center of the

earth. In the diagram angles A and A' are equal. The exception previously mentioned is the moon, whose rays, by reason of the moon's proximity to the earth, are not parallel, and which, therefore, requires different treatment in solution.

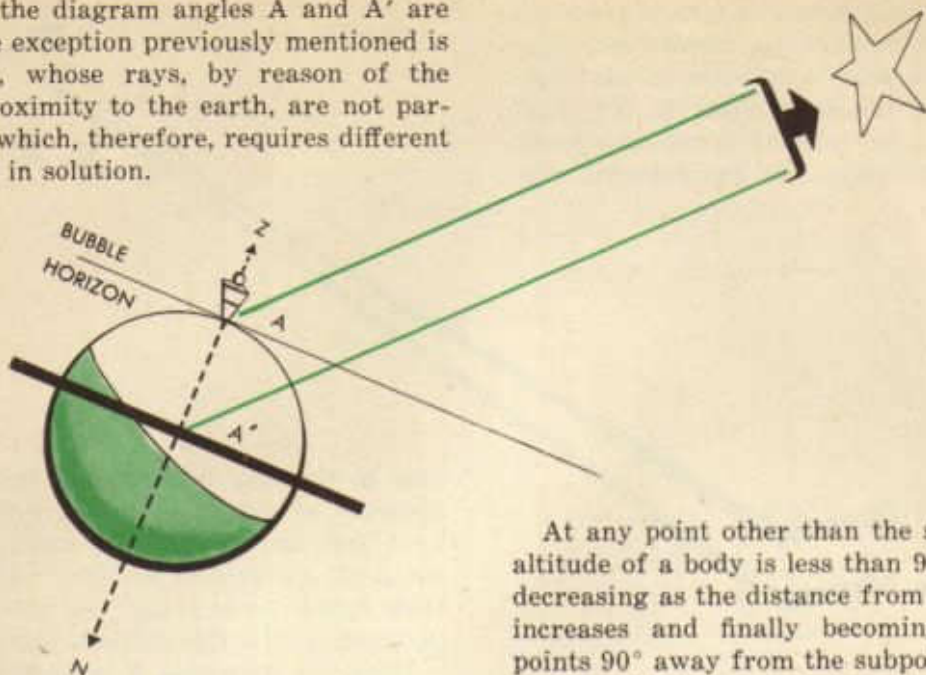

3. Altitude

If a body is directly over an observer or at his zenith, that is, if the observer is located at its subpoint, the angle between the bubble horizon at his position and the ray of light from the body to him is 90° . This angle between the horizon and the straight line from the body of the observer's position is called *altitude*, or more specifically, *observed altitude (H_o)*, to distinguish it from other types of altitude of concern to the navigator. Remember that in celestial computations the observer is assumed to be at the center of the earth so that altitude may also be regarded as the angle at the center of the earth between the celestial horizon and a straight line from the body. As previously discussed, the magnitude of the angle is the same wherever the observer is considered to be except in the case of the moon.

At any point other than the subpoint, the altitude of a body is less than 90° , the angle decreasing as the distance from the subpoint increases and finally becoming 0° at all points 90° away from the subpoint. The altitude of the body at A, its subpoint, is 90° , while the altitude at B, a distance of 90° on the surface of the earth from A, is 0° . Since 90° on the surface of the earth is equal to 5400 nautical miles, it is apparent that there is a definite relationship between H_o and the linear distance of the observer from the subpoint.

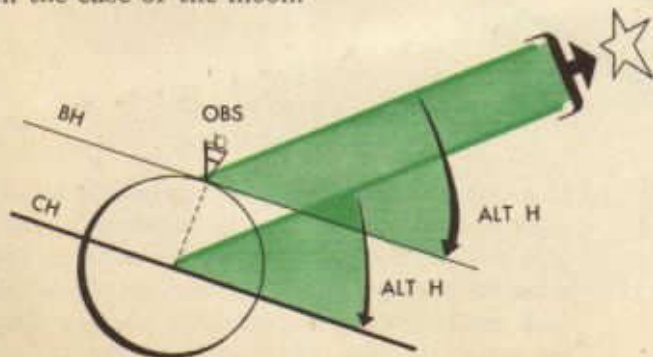
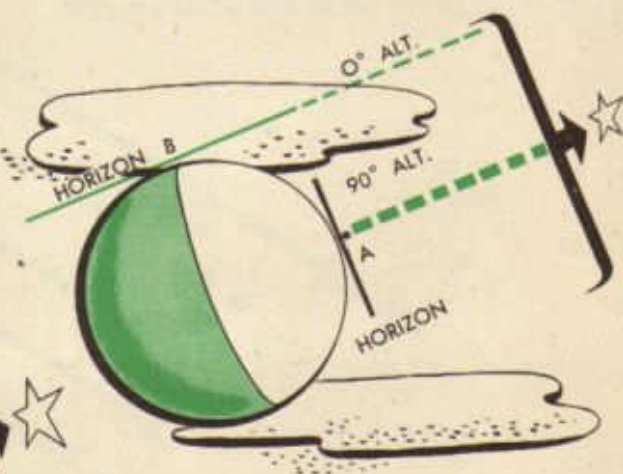

For instance, at a point 1' away from the subpoint, the Ho would be $89^{\circ}59'$; at a point 1800 nautical miles or 30° , away, 60° , etc. Thus it is seen that the distance of the observer away from the subpoint is the complement of the Ho converted to linear measure. This distance is called *co-altitude (Co-alt)* or *zenith distance* and may be expressed as an angle or converted to linear measurement.

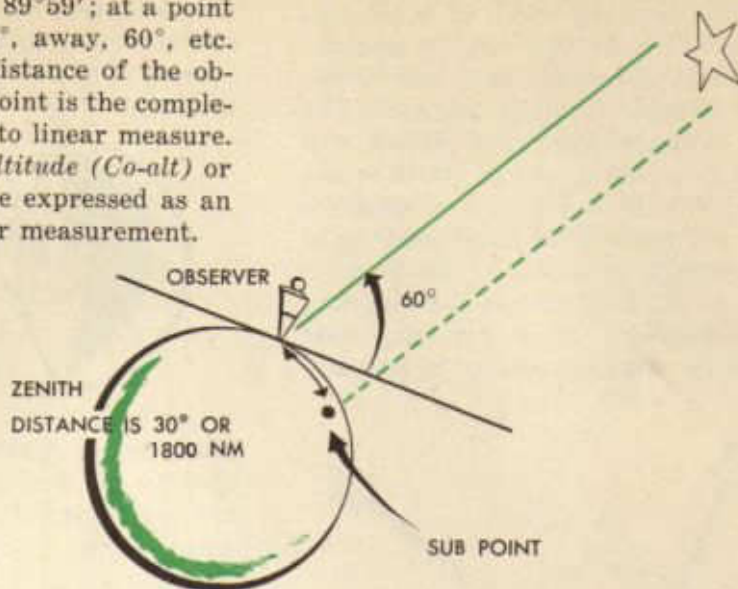

In the sextant the navigator has the means for measuring directly the altitude of a heavenly body. The altitude measured by sextant is termed *sextant altitude (Hs)*, and, when corrected for errors of observation, becomes the actual altitude of the body at the point of observation or the Ho already defined.

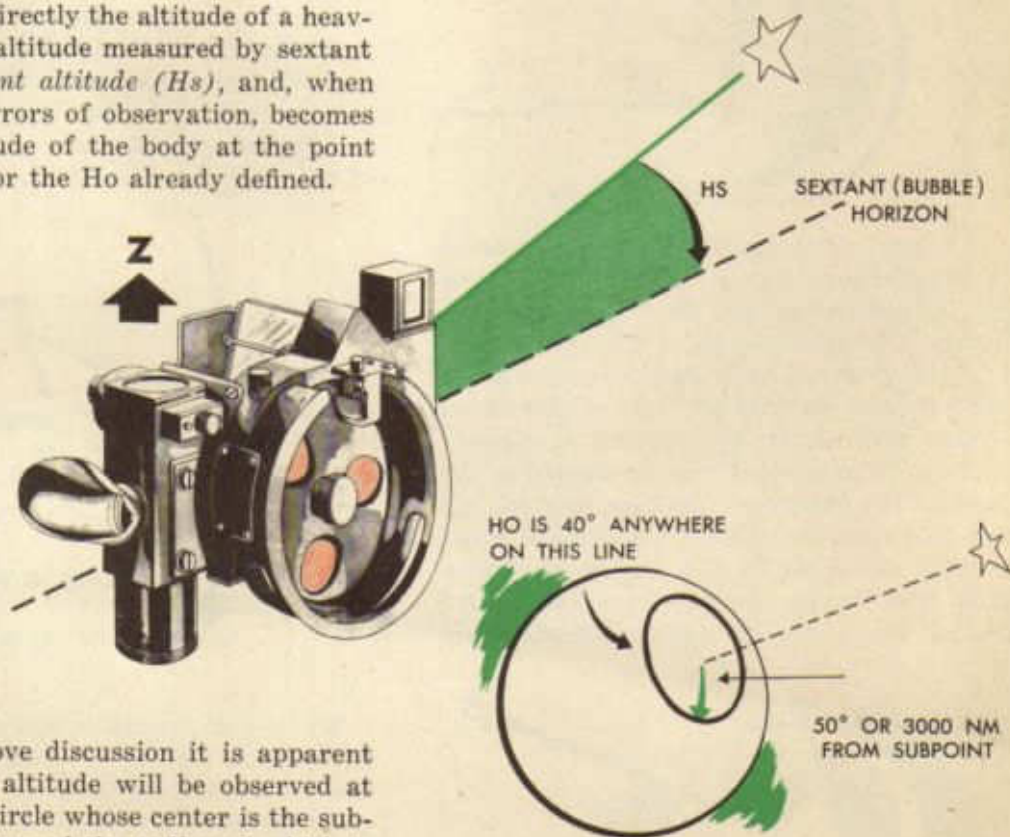

From the above discussion it is apparent that any given altitude will be observed at any point on a circle whose center is the subpoint of the body and the radius of which is the zenith distance. Such a circle is called a *circle of equal altitude*. Thus, when a navigator observes an altitude of 40° , he knows that at the time of observation he is at some point

on a circle at a distance of 50° or 3000 nautical miles from the subpoint of the body observed.

Since the navigator does not know exactly his location on this vast circle of equal altitude, he can fix his position only by measuring the altitude of another body and determining his distance from its subpoint. The two circles of equal altitude, if plotted, will intersect at two points, one of which is the navigator's position at the time of observation. There will never be any ambiguity as to which intersection to choose as the fix position, since, as is illustrated in the diagram, the two intersections are so far apart that dead reckoning will show one to be patently impossible.

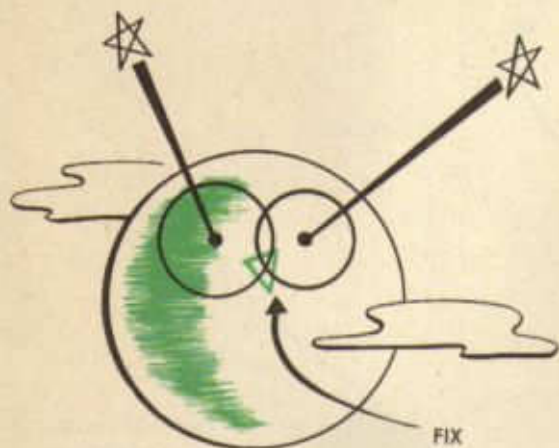

It might be thought that an observer could fix his position from an observation of one body by measuring both its altitude and true bearing. The true bearing of a heavenly body is called *true azimuth* and corresponds in every way to the true bearings of terrestrial objects with which the student is already familiar. True azimuth may be defined as the angle at the observer's position between his meridian and the radius of his circle of equal altitude measured to this radius clockwise from true north. As the observer moves around the circle of equal altitude it is

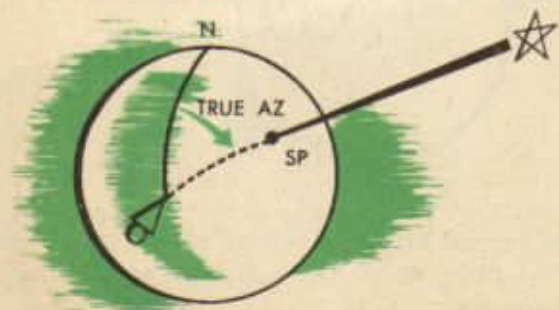

apparent that true azimuth changes so that theoretically a fix obtained from the intersection of the circle of equal altitude and the bearing of the subpoint from the observer is possible.

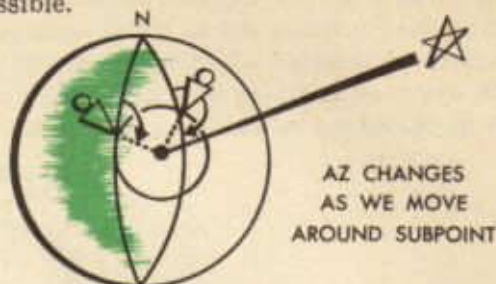

However, in practice such a fix is unobtainable. In the first place, no instrument has so far been devised which will insure measurement within 1° of accuracy. Assuming the subpoint to be 3000 nautical miles distant from the observer, such an error would result in an error of 50 nautical miles in the fix, which is not precise enough for navigational purposes. Even if the azimuth of a body could be measured exactly, the navigator does not carry a globe nor does he have sufficiently large charts upon which the subpoint of any body can be plotted.

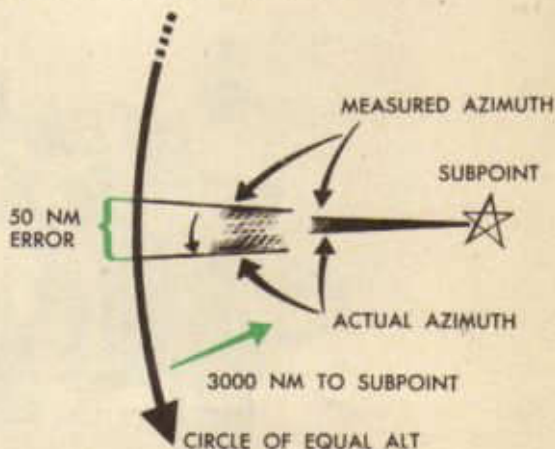

So far the discussion has proceeded on the assumption that at the time of observation the position of the subpoint was known. No explanation of the manner in which the navigator locates this point has been offered and since a fix cannot be obtained without first determining its coordinates, establishment of the subpoint follows as the logical matter for inquiry.

Solving for Azimuth and Intercept

Instruments were very crude when man first learned to navigate without reference to terrestrial landmarks, but very accurate navigation was done. Polynesians made 2,500- to 3,000-mile journeys to New Zealand and Hawaii with little more than a memory of the relative positions of the celestial bodies.



New instruments and techniques are constantly being introduced, and these refinements must be evaluated and accepted if worthwhile.

Changes, however, do not necessarily imply a revision of the whole concept of celestial navigation. Navigation by celestial methods has been and is the art of establishing lines of position on the surface of the earth by reference to the stars and planets in the sky. These lines of position once established can be used in the same manner as those obtained by any other means. For this reason it has been found that dead reckoning must accompany this as well as any other method of navigation.

Celestial navigation has become much more accurate since these twelfth century days; however, the improvement has been concerned mainly with instruments rather than theory. Basically, people of ancient times understood navigation as it is known today. With the advent of precision instruments, numerous aids to accurate navigation have been devised.

This method of directing aircraft is considered another aid to dead reckoning. It provides an accurate means of checking position when conditions are such that visual or radio bearings cannot be obtained. This method, then, provides information which, when combined with the previously explained material, enables the navigator to ascertain position under almost any condition. It is the final "rounding out" of the navigator's sphere of technical knowledge, but this "rounding out" process is never complete.



Just as radio can be reduced to a mechanical procedure for extending visual bearings beyond the horizon, so can celestial navigation be reduced with the proper instruments and materials. Thus, by disregarding the theory of star movement this procedure can be simply stated as including the knowledge of the use and interpretation of the proper instruments and materials. Undoubtedly, the navigator must learn to recognize navigational stars, but this is purely a matter of memory.

The apparatus necessary for establishing a celestial line of position includes a sextant for measuring the height or altitude of a star, an accurate timepiece, tables to aid in the interpretation of information concerning a celestial body, and a plotting sheet with accompanying instruments for recording the line of position. Such apparatus provides sufficient material with which to establish the position of the aircraft.

The first step, assuming the celestial bodies have been memorized, is concerned with the selection of a star. Unlike radio, a body ahead or behind the aircraft will provide a

speedline. If a course line is desired a body to the right or left must be selected.

When a star has been selected its altitude must be determined. An instrument which measures this angle at the observer's eye between a line to the star and a line horizontal to the earth has been devised. A relatively simple sextant includes an eyepiece through which light from the celestial body shines after being reflected from several mirrors. One of these mirrors is movable in order to allow the field of vision to range from the horizon to a point directly above the observer's head while the instrument remains level.

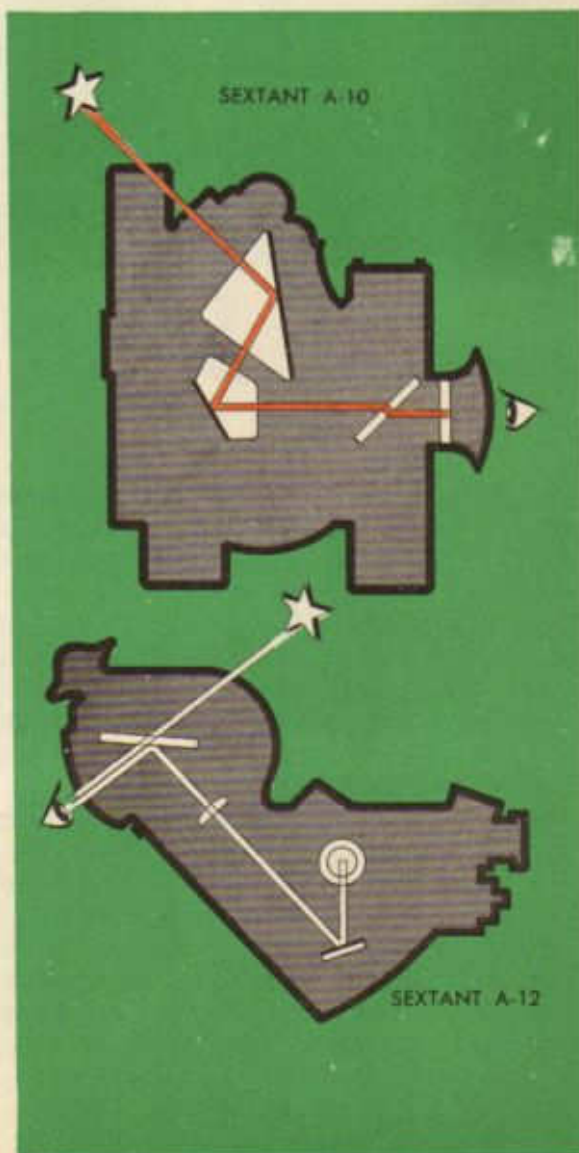

A bubble, much like a carpenter's level, is placed within the line of sight in such a manner that when the sextant is level the bubble can be seen in the center of the field of vision. An arm is attached to the movable mirror so that the angle of sight measured from the horizon can be determined. This pointer arm moves over a scale graduated in such a manner that angles between 0° and 90° can be read to the nearest one-half minute.

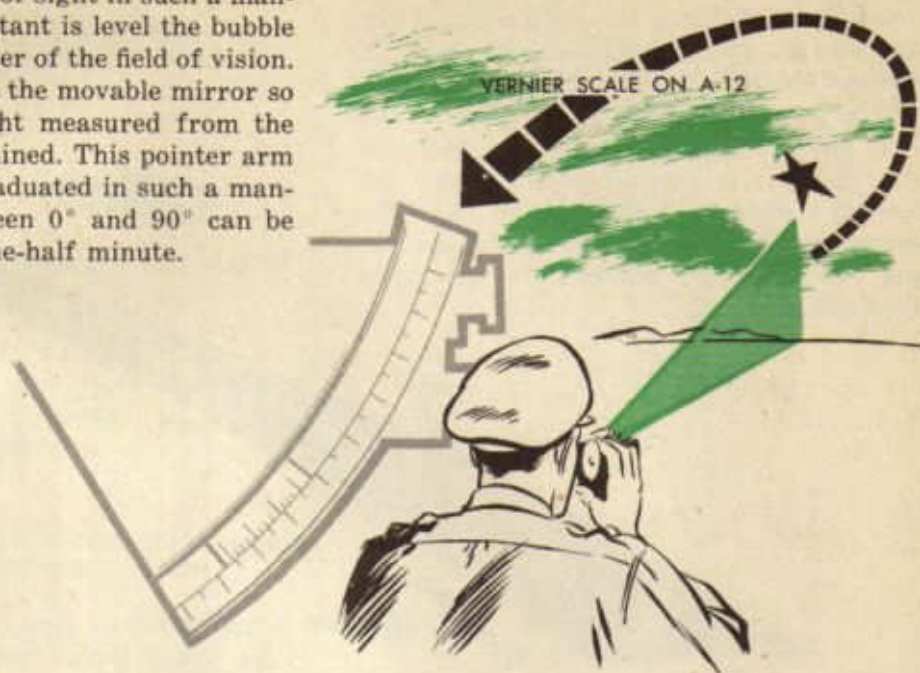

With this mechanical apparatus the altitude of the selected body can be ascertained by pointing the sextant in the proper direction, keeping it level by reference to the bubble in the field of vision, and rotating the movable mirror until the star shines through the bubble. The time to the exact second can now be observed and the altitude of the star taken from the pointer position on the scale. This is called the observed altitude or H_o .



By use of the *American Air Almanac* and the *Astronomical Navigation Tables* it is possible to compute the exact altitude (H_c) and direction (azimuth) of the star from any position where it is visible at the time the observed altitude (H_o) was obtained. It



is very important to remember that the altitude of a body above the horizon as seen from any position (called *assumed position*) can be calculated exactly. This is the basic fact underlying the solution of the astronomical triangle by H.O. 218.

Thus, if the observer were actually at the assumed position, the H_o would be the same as the H_c . If the observer were closer to the star than the assumed position, H_o would be greater than H_c . Conversely, if the observer were farther away, H_o would be less than H_c . With this relationship of the two altitudes established, it is possible to determine the observer's distance and direction from the assumed position at the time of the observation. The difference between H_o and H_c is called the *intercept*.

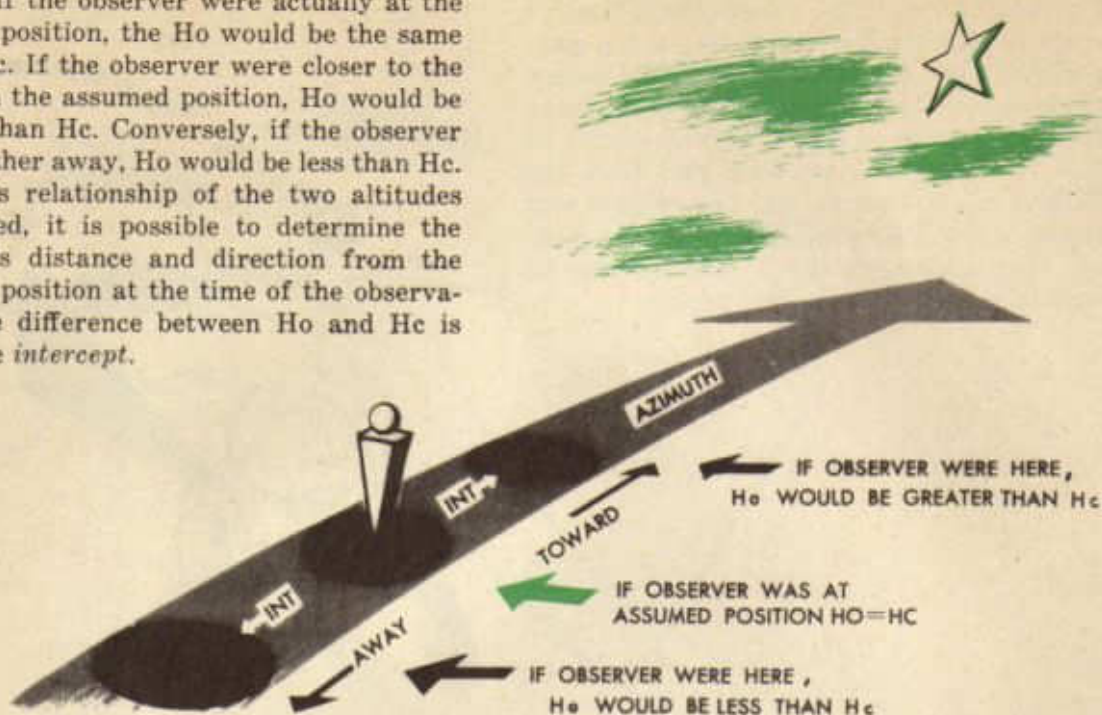

The almanac and tables used to calculate H_c are made up for a specific time and latitude. In order to keep the number of books to a minimum, the time is based on that at the prime meridian, or Greenwich, England. It has been found that a celestial body travels over 15° of longitude in one hour. In other words, if the sun is directly over the prime meridian at 12:00 o'clock (called 1200 GCT) it will be directly over the 15° W meridian one hour later (1300 GCT). However, the local time at 15° W will be 12:00 o'clock (called 1200 LCT).

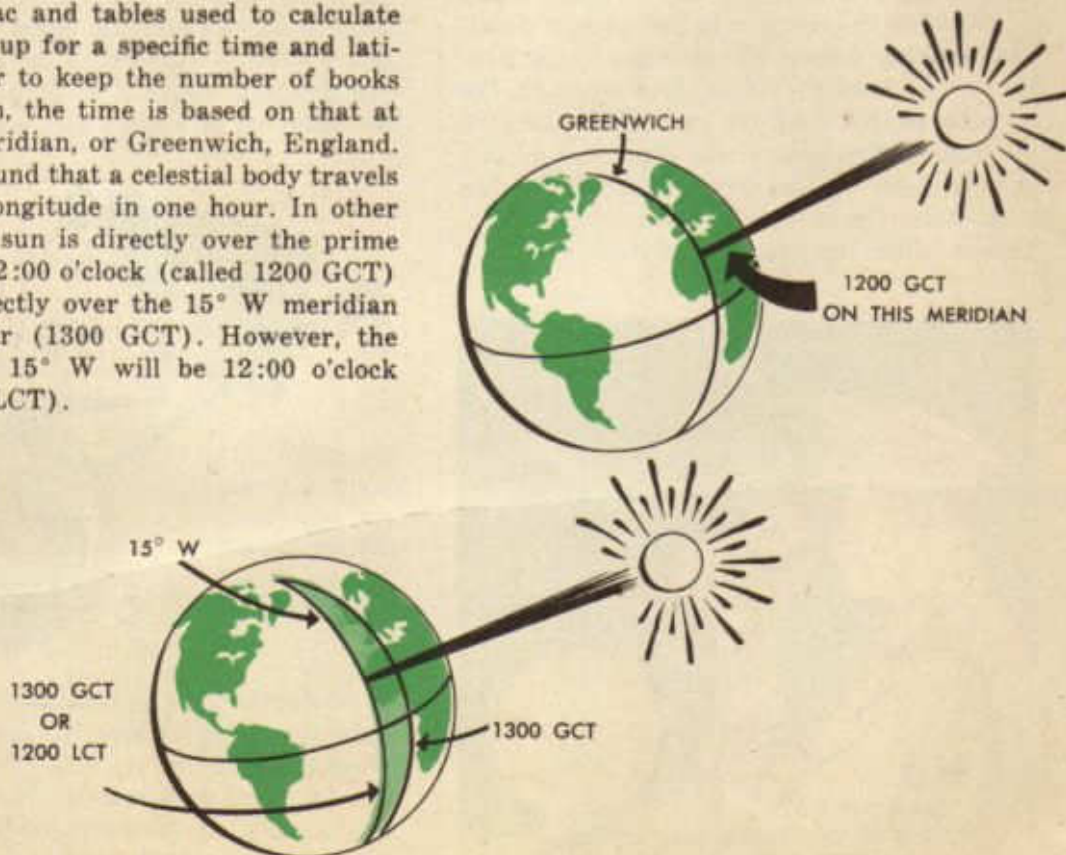

It will be remembered that the United States has Eastern, Central, Mountain, and Pacific time zones. The center meridian of each of these zones is respectively 75°, 90°, 105°, and 120° West. In relation to the prime meridian these zones may therefore be re-named the 5, 6, 7, and 8th time zones.

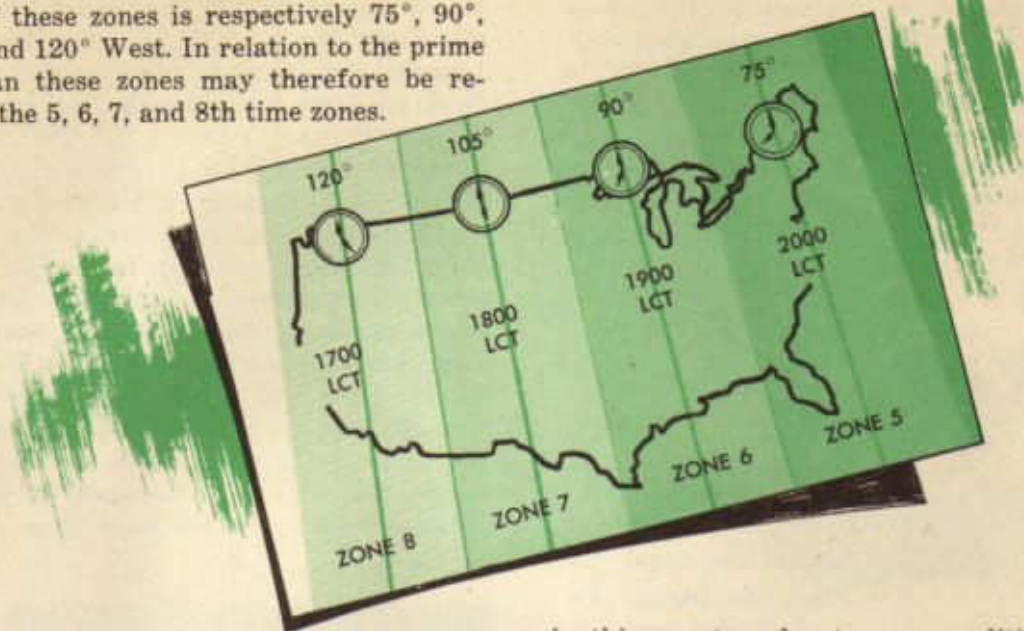

Each zone extends $7\frac{1}{2}^\circ$ to either side of its center meridian. The number of the zone depends upon the number of 15° intervals it contains. For instance, the 90° meridian contains six 15° intervals; therefore, it becomes the center of the 6th zone, and its time is exactly six hours earlier than that at Greenwich. Since time has been advanced one hour

in this country, due to war conditions, the difference amounts to only five hours. Thus, when it is 0800 in the sixth time zone, it is 1300 at Greenwich ($0800 + 0500$ or 1300). Likewise, when it is 2000 in the same zone, it is $2000 + 0500$ or 0100 the next day at Greenwich. For zones to the east of the prime meridian, you must subtract the correction from the local time in order to obtain Greenwich time.

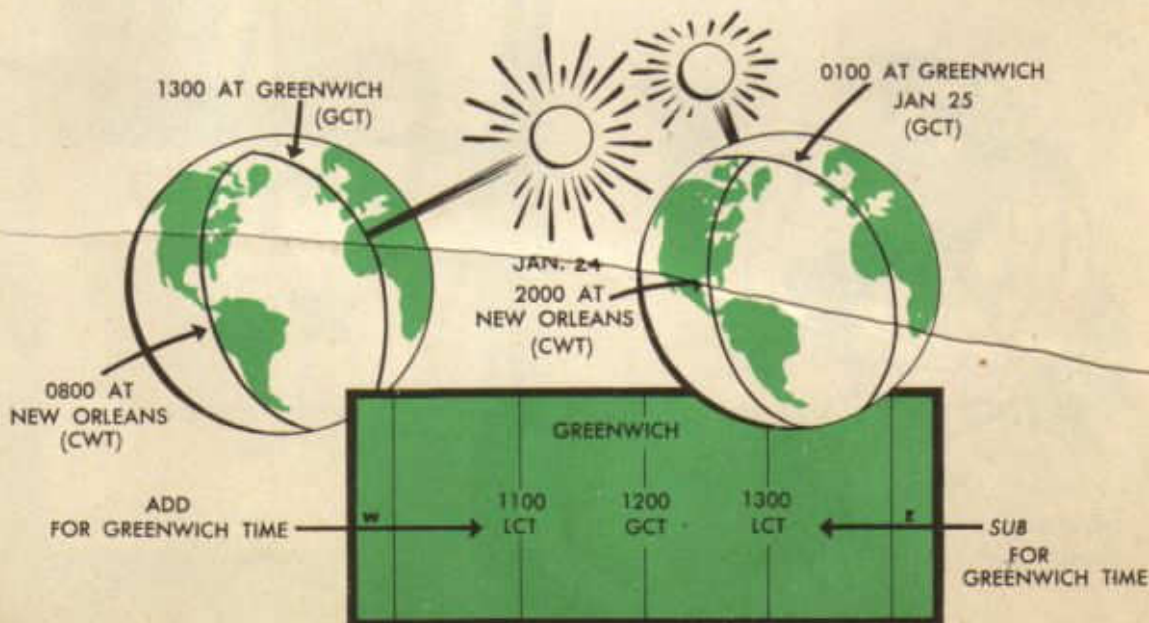

A fuller explanation of time will be presented later. At present it is only necessary for the observer either to set Greenwich time on the timepiece or to remember the correction which must be applied to obtain Greenwich time. If Central War Time (CWT) is placed on a watch, the observer can quickly obtain Greenwich time by adding five hours to the observed time. This relation holds true regardless of the location of the observer whether in New Orleans or Berlin as long as CWT is indicated by the watch.



REGARDLESS OF WHAT
TIME IS ON WATCH, THERE
IS ONLY ONE CORRECTION
FROM THAT TIME TO TIME
AT GREENWICH

For the purpose of explanation, assume that Altair was observed from $29^{\circ}25'N-95^{\circ}05'W$ on Monday, September 6, 1943, at $02^h 15^m 30^s$ CWT. The H_o obtained from sextant observation was $29^{\circ}13'$. By adding five hours to Central War Time, the Greenwich Civil Time (GCT) is calculated to be $07^h 15^m 30^s$. Using the reproduced page from the Air Almanac in the following steps, you



can determine the Hc. Enter the page with $07^h 10^m$ GCT and obtain $GHA \Upsilon$ (called Greenwich Hour Angle of Aries) from the second column ($92^{\circ}00'$). Adjust for the additional $05^m 30^s$ is made by referring to the Interpolation of GHA table located inside the front cover of the almanac. The correction for $05^m 30^s$ is found to be $1^{\circ}23'$. This is added to the $07^h 10^m$ $GHA \Upsilon$ to obtain $GHA \Upsilon$ for $07^h 15^m 30^s$. Another adjustment must be made for the fact that Altair is not located along the Aries meridian in the sky. Since the distance between Altair and Aries remains constant this correction remains the same, and it is found in the star table inside the front cover of the almanac. This correction ($63^{\circ}00'$) is in the SHA column opposite the name of the star, Altair. It is added to $GHA \Upsilon$ for $07^h 15^m 30^s$ to obtain the GHA of Altair ($156^{\circ}23'$) for the same time.



GCT	☉ SUN		♃	♂ MARS 0.0		♃ JUPITER -1.4		♄ SATURN 0.3		☾ MOON		☾ Par.
	GHA	Dec.		GHA	GHA	Dec.	GHA	Dec.	GHA	Dec.	GHA	
0 00	180 19	N 6 52	344 13	278 52	N20 10	206 59	N16 59	258 57	N22 01	111 42	S13 39	
10	182 49		346 43	281 22		209 29		261 27		114 07	S13 40	
20	185 19		349 14	283 52		211 59		263 58		116 32	S13 41	
30	187 49		351 44	286 23		214 30		266 28		118 57	S13 43	
40	190 19		354 14	288 53		217 00		268 59		121 22	S13 44	
50	192 49		356 45	291 23		219 30		271 29		123 47	S13 46	
1 00	195 19	N 6 51	359 15	293 53	N20 11	222 01	N16 59	273 59	N22 01	126 12	S13 47	
10	197 49		4 16	296 23		224 31		276 30		128 37	S13 48	
20	200 19		4 16	298 54		227 01		279 00		131 02	S13 50	
30	202 49		6 46	301 24		229 32		281 30		133 27	S13 51	
40	205 19		9 17	303 54		232 02		284 01		135 52	S13 52	
50	207 49		11 47	306 24		234 32		286 31		138 17	S13 54	
2 00	210 19	N 6 50	14 18	308 54	N20 11	237 03	N16 59	289 02	N22 01	140 42	S13 55	
10	212 49		16 48	311 25		239 33		291 32		143 07	S13 57	
20	215 19		19 19	313 55		242 03		294 02		145 32	S13 58	
30	217 49		21 49	316 25		244 34		296 33		147 57	S13 59	
40	220 19		24 19	318 55		247 04		299 03		150 22	S14 01	
50	222 49		26 50	321 25		249 34		301 34		152 46	S14 02	
3 00	225 19	N 6 49	29 20	323 56	N20 11	252 05	N16 59	304 04	N22 01	155 11	S14 04	
10	227 49		31 51	326 26		254 35		306 34		157 36	S14 05	
20	230 19		34 21	328 56		257 05		309 05		160 01	S14 06	
30	232 49		36 51	331 26		259 36		311 35		162 26	S14 08	
40	235 20		39 22	333 56		262 06		314 05		164 51	S14 09	
50	237 50		41 52	336 26		264 36		316 36		167 16	S14 10	
4 00	240 20	N 6 48	44 23	338 57	N20 11	267 07	N16 59	319 06	N22 01	169 41	S14 12	
10	242 50		46 53	341 27		269 37		321 37		172 06	S14 13	
20	245 20		49 23	343 57		272 07		324 07		174 31	S14 14	
30	247 50		51 54	346 27		274 38		326 37		176 56	S14 16	
40	250 20		54 24	348 57		277 08		329 08		179 21	S14 17	
50	252 50		56 55	351 28		279 38		331 38		181 45	S14 18	
5 00	255 20	N 6 47	59 25	353 58	N20 12	282 08	N16 59	334 09	N22 01	184 10	S14 20	
10	257 50		61 56	356 28		284 39		336 39		186 35	S14 21	
20	260 20		64 26	358 58		287 09		339 09		189 00	S14 22	
30	262 50		66 56	3 28		289 39		341 40		191 25	S14 24	
40	265 20		69 27	3 59		292 10		344 10		193 50	S14 25	
50	267 50		71 57	6 29		294 40		346 40		196 15	S14 26	
6 00	270 20	N 6 46	74 28	8 59	N20 12	297 10	N16 58	349 11	N22 01	198 40	S14 28	
10	272 50		76 58	11 29		299 41		351 41		201 05	S14 29	
20	275 20		79 28	13 59		302 11		354 12		203 30	S14 30	
30	277 50		81 59	16 30		304 41		356 42		205 54	S14 32	
40	280 20		84 29	19 00		307 12		359 12		208 19	S14 33	
50	282 50		87 00	21 30		309 42		1 43		210 44	S14 34	
7 00	285 20	N 6 45	89 30	24 00	N20 12	312 12	N16 58	4 13	N22 01	213 09	S14 36	
10	287 50		92 00	26 30		314 43		6 44		215 34	S14 37	
20	290 20		94 31	29 01		317 13		9 14		217 59	S14 38	
30	292 50		97 01	31 31		319 43		11 44		220 24	S14 40	
40	295 20		99 32	34 01		322 14		14 15		222 49	S14 41	
50	297 50		102 02	36 31		324 44		16 45		225 13	S14 42	
8 00	300 20	N 6 44	104 32	39 01	N20 12	327 14	N16 58	19 15	N22 01	227 38	S14 44	
10	302 50		107 03	41 32		329 45		21 46		230 03	S14 45	
20	305 20		109 33	44 02		332 15		24 16		232 28	S14 46	
30	307 51		112 04	46 32		334 45		26 47		234 53	S14 48	
40	310 21		114 34	49 02		337 16		29 17		237 18	S14 49	
50	312 51		117 05	51 32		339 46		31 47		239 43	S14 50	
9 00	315 21	N 6 43	119 35	54 02	N20 13	342 16	N16 58	34 18	N22 01	242 08	S14 51	
10	317 51		122 05	56 33		344 47		36 48		244 32	S14 53	
20	320 21		124 36	59 03		347 17		39 19		246 57	S14 54	
30	322 51		127 06	61 33		349 47		41 49		249 22	S14 55	
40	325 21		129 37	64 03		352 18		44 19		251 47	S14 57	
50	327 51		132 07	66 33		354 48		46 50		254 12	S14 58	
10 00	330 21	N 6 42	134 37	69 04	N20 13	357 18	N16 58	49 20	N22 01	256 37	S14 59	
10	332 51		137 08	71 34		359 49		51 50		259 01	S15 00	
20	335 21		139 38	74 04		2 19		54 21		261 26	S15 02	
30	337 51		142 09	76 34		4 49		56 51		263 51	S15 03	
40	340 21		144 39	79 04		7 20		59 22		266 16	S15 04	
50	342 51		147 09	81 35		9 50		61 52		268 41	S15 06	
11 00	345 21	N 6 41	149 40	84 05	N20 13	12 20	N16 58	64 22	N22 01	271 06	S15 07	
10	347 51		152 10	86 35		14 50		66 53		273 30	S15 08	
20	350 21		154 41	89 05		17 21		69 23		275 55	S15 09	
30	352 51		157 11	91 35		19 51		71 54		278 20	S15 11	
40	355 21		159 42	94 06		22 21		74 24		280 45	S15 12	
50	357 51		162 12	96 36		24 52		76 54		282 10	S15 13	
12 00	0 21	N 6 40	164 42	99 06	N20 13	27 22	N16 58	79 25	N22 01	285 35	S15 14	



If the observer were at the Greenwich meridian, no further adjustment would be necessary, since the angular distance of the star from Greenwich meridian (GHA Altair) has been calculated. But the observer is at $95^{\circ}05'$ West longitude; therefore this angle must be subtracted from the GHA Altair to obtain the angular distance of the star from the observer's (local) meridian. This angular distance, called LHA Altair, must, however, be a whole number of degrees because the navigation tables are printed for only whole degrees of LHA. In order to make LHA Altair a whole number of degrees, the longitude of the observer must be shifted to the east or west. In this case the GHA Altair ($156^{\circ}23'$) minus the observer's longitude ($95^{\circ}05'W$) will not result in a whole number; but $156^{\circ}23'$ minus $95^{\circ}23'W$ leaves $61^{\circ}00'$. This is the LHA Altair of an observer assumed to be at $95^{\circ}23'$ West longitude.

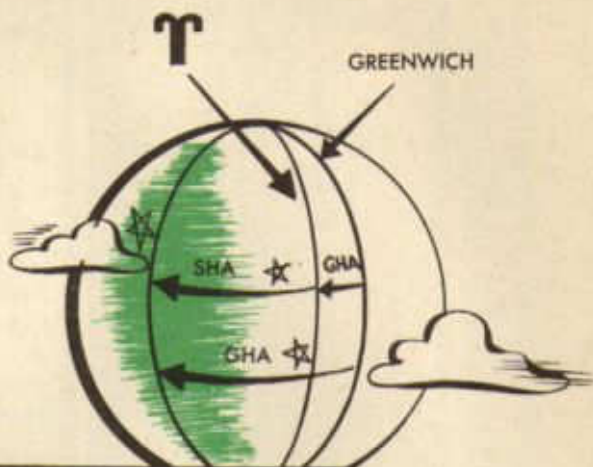

GREENWICH

$$SHA \star + GHA \tau = GHA \star$$

OBSERVER

$$GHA \star - W \text{ LONG} = LHA \star$$

W LONG

The latitude of the observer is $29^{\circ}25'N$; therefore Volume F ($25^{\circ}-29^{\circ}$) of the Astronomical Navigation Tables is used. The nearest degree of latitude, 29° , is used in the computation. Under the list of 22 selected stars at the front of the book, Altair is found to be number 5. Upon turning to this star division

(5), calculations for North and South latitudes are noted. Since the observer is in the northern hemisphere, the North latitude pages must be used. The extreme right and left columns or arguments on each page contain LHA Altair values. Across the top of each page whole degrees of latitude are recorded. Thus, when the LHA Altair is 61° and the latitude is 29° the Hc becomes 29°



32'. The direction of the star from this position is found by recording the azimuth as given in the same column. In this case, by referring to the bottom of the page the true azimuth (direction) of Altair is found to be 360° minus the tabulated azimuth (097) or 263° . This is the true direction of Altair from the assumed position $29^\circ 00' N - 95^\circ 23' W$. This position must be plotted on the Mercator together with the azimuth extending on each side.

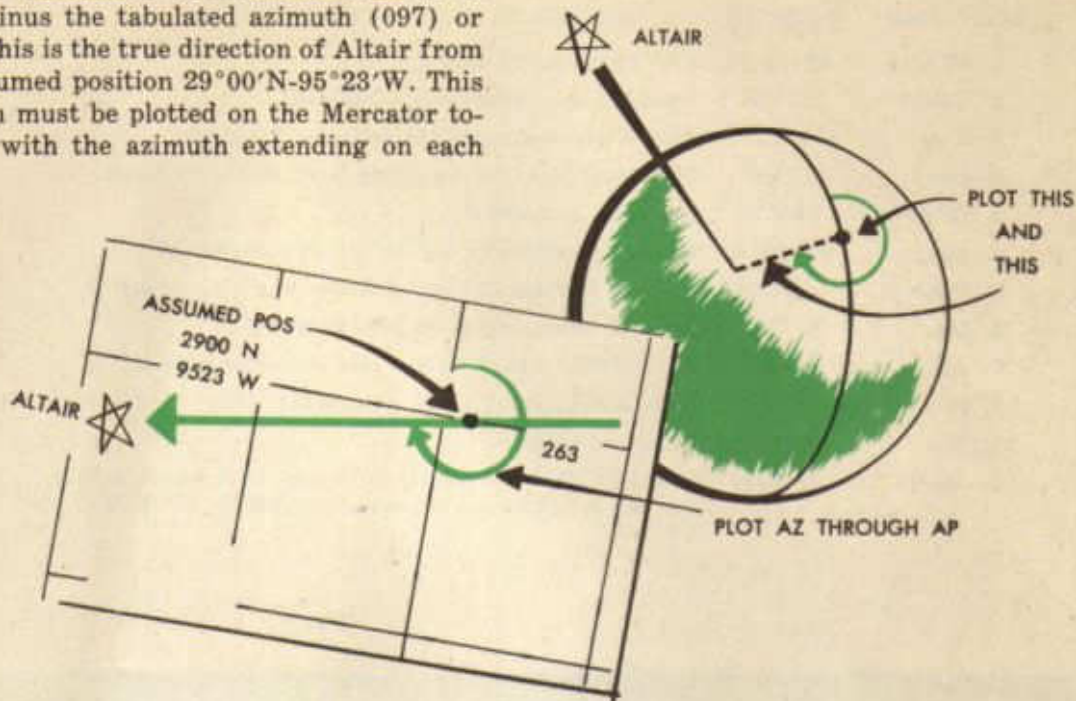

If the observer had been at this position, the observed altitude (H_o) would have been the same as the computed altitude (H_c). But the H_o was $29^\circ 13'$ or $19'$ less than H_c . Since one minute of arc on a great circle equals one nautical mile, the observer is 19 nautical miles from the assumed position ($29^\circ 00' N - 95^\circ 23' W$) along the azimuth of the star. Since H_c is greater than H_o , the observer must be away from the star; therefore, a point 19 miles from the assumed position is

located on the reciprocal of the azimuth. In other words, the assumed position is between the observer and the star. Through this point a perpendicular is erected.

This perpendicular is the observer's line of position, and it will be found to fall through $29^\circ 25' N - 95^\circ 05' W$, which was the observer's position at the time the observation was taken. Ordinarily, however, it is a line of position which is used in the same manner as any other LOP.

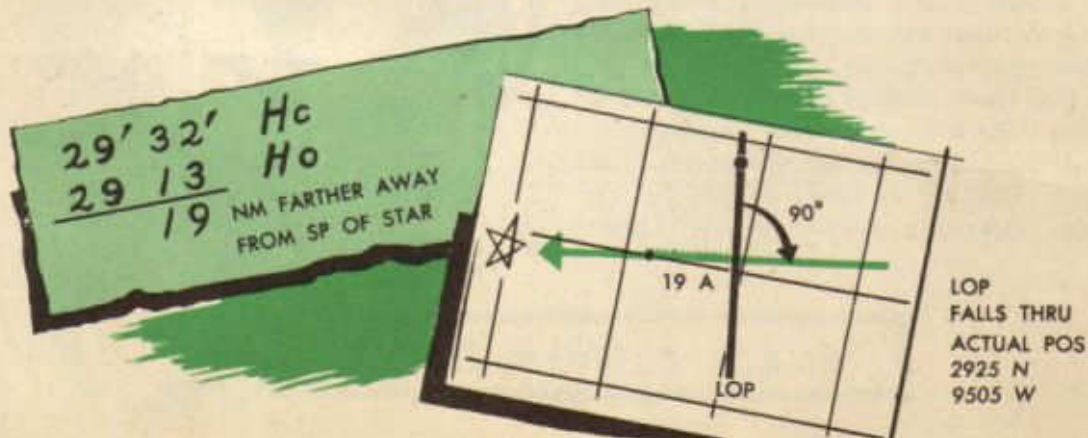

BODY: Altair	Ho: 29°13'	DATE: 9-6-43	CWT: 02 ^h 15 ^m 30 ^s
1. GCT	07-15-30	CWT converted to GCT	
2. GHA \uparrow	92°00'	From Almanac opposite 07-10-00 GCT	
3. Corr.	1°23'	From Interpolation of GHA table for 5 ^m 30 ^s	
4. Corr.	63°00'	SHA Altair from star list inside back cover of Almanac	
5. GHA*	156°23'	Add steps 2, 3, and 4	
6. Long.	95°23'W	Nearest meridian to 95°05' which contains 23'	
7. LHA*	61°00'	Must be a whole number. Subtract step 6 from step 5	
8. Lat.	29°00'N	Nearest whole degree of latitude to 29°25'N	
9. Az.	263°	From A.N.T., Vol. F. Follow rule at bottom of page	
10. Hc	29°32'	From A.N.T., Vol. F., LHA 61 and Lat. 29°	
11. Ho	29°13'	Observed altitude	
12. Inter.	19 away	LOP erected perpendicular to True Az. 19 miles away from the star in relation to the assumed position 29°00'N-95°23'W	

In the following example where the observer is located in south latitude and east longitude (33°10'S-60°16'E), a slightly different calculation is demanded. In the first place, it must be remembered that the local civil time (LCT) at this longitude is four hours ahead of Greenwich civil time (GCT); therefore, four hours must be subtracted from LCT to find GCT.

The second major change is concerned with the fact that the observer is now in east longitude instead of west. It will be remembered that west longitude was subtracted from the GHA* to obtain the angular distance of the star from the observer's local meridian (LHA*). In order to find LHA* from the observer's position in east longi-

tude, the longitude must be *added* to GHA*. This is obviously true when it is remembered that LHA* is always measured *clockwise* from the observer's meridian to the star.

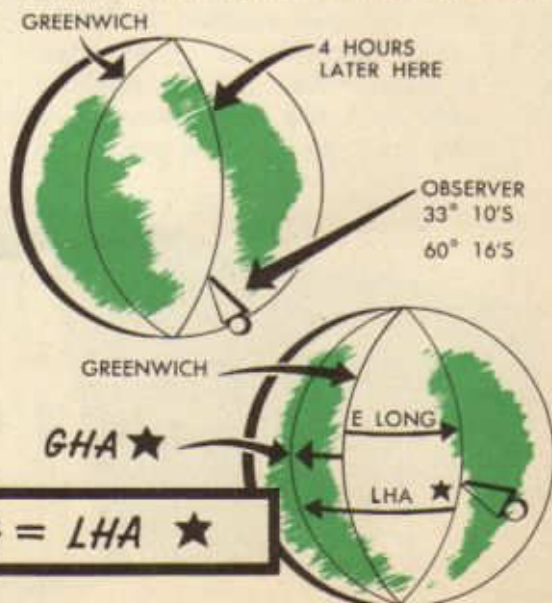

Suppose that Sirius was observed from $33^{\circ}10'S-60^{\circ}16'E$ on Monday, September 6, 1943, at $05^h 17^m 30^s$ LCT. The Ho obtained

from sextant observation was $53^{\circ}04\frac{1}{2}'$. The line of position can be determined by the following calculations:

BODY: Sirius	Ho: $53^{\circ}04\frac{1}{2}'$	DATE: 9-6-43	LCT: $05^h 17^m 30^s$
1. GCT	01-17-30	LCT - 4 hr. Fourth time zone in east longitude	
2. GHA \uparrow	$1^{\circ}46'$	From Almanac opposite 01-10-00 GCT	
3. Corr.	$1^{\circ}53'$	From Interpolation of GHA table for $07^m 30^s$	
4. Corr.	$259^{\circ}20'$	SHA Sirius from star list inside back cover of Almanac	
5. GHA*	$262^{\circ}59'$	Add steps 2, 3, and 4	
6. Long.	$60^{\circ}01'E$	DR longitude adjusted to make LHA* a whole degree	
7. LHA*	$323^{\circ}00'$	Add steps 5 and 6. East longitude; remember?	
8. Lat.	$33^{\circ}00'S$	Nearest whole degree of latitude to $33^{\circ}10'S$	
9. Az.	73°	From A.N.T. Vol. G. Follow rule at bottom of South Latitude page	
10. Hc	$52^{\circ}55'$	From A.N.T. Vol. G. Arguments: LHA 323° and Lat. $33^{\circ} S$.	
11. Ho	$53^{\circ}04\frac{1}{2}'$	Observed altitude.	
12. Inter.	$9\frac{1}{2}'$	Toward; LOP erected perpendicular to True Azimuth $9\frac{1}{2}$ miles toward the star from assumed position $33^{\circ}00' S-60^{\circ} 01' E$.	

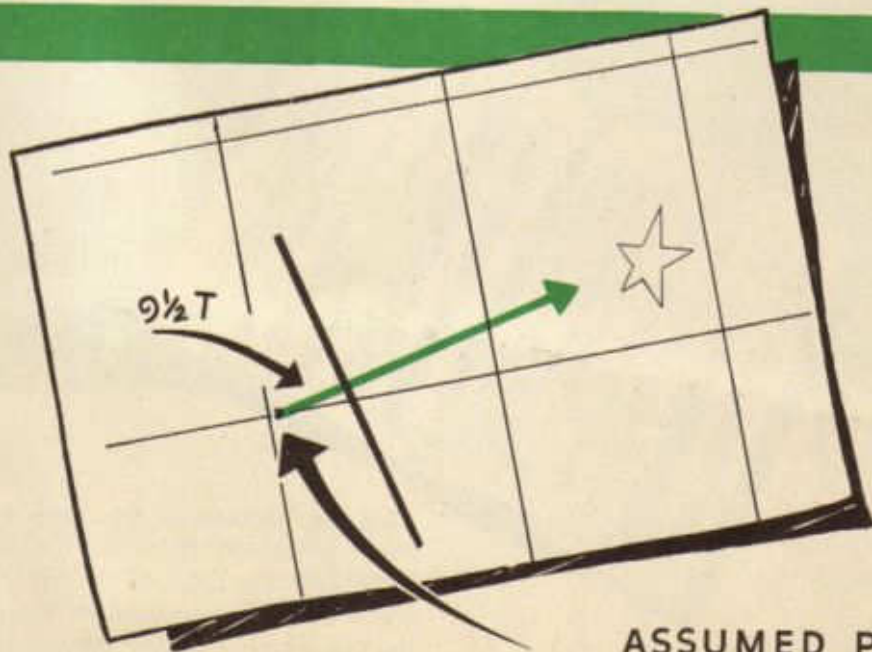

ASSUMED POS
 $33^{\circ}00'S$ $60^{\circ}01'E$

When actually recording the line of position, the usual method of plotting in south latitudes must be observed.

Solutions of the astronomical triangle by this method (H.O. 218) may be accomplished for twenty-two navigation stars. These stars together with their numbers are listed in each volume of A.N.T. Unfortunately, however, these stars are available only at night.

Since lines of position are just as desirable during the daylight hours, some means must be devised by which the sun, and occasionally the moon, can be used. For various reasons observations taken on the sun, moon, planets, and several stars with declinations less than 29° require a slightly different solution from that applied to the 22 navigational stars listed in A.N.T.

As an example, suppose a sextant observation was taken on the sun at $07^h 59^m 45^s$ EWT on Monday, September 6, 1943. The approximate position of the observer at the time of the observation, according to dead reckoning, was $31^\circ 42' N - 77^\circ 16' W$. The Ho from the sextant was $14^\circ 46'$.

GCT is calculated to be $11^h 59^m 45^s$; therefore the almanac is turned to the proper page and entered with this data. The first column to the right of the GCT column lists the GHA of the sun and its declination. Declination is merely the angular distance of the body north or south of the equator. The GHA of the sun for $11^h 50^m$ GCT ($357^\circ 51'$) is recorded along with the nearest indicated declination ($N6^\circ 40'$). Adjustment for the remaining $09^m 45^s$ is made as usual from the Interpolation of GHA table ($2^\circ 26'$). Thus, the GHA of the sun for $11^h 59^m 45^s$ GCT is found to be $360^\circ 27'$. Since the GHA of the sun is recorded directly, no adjustment for

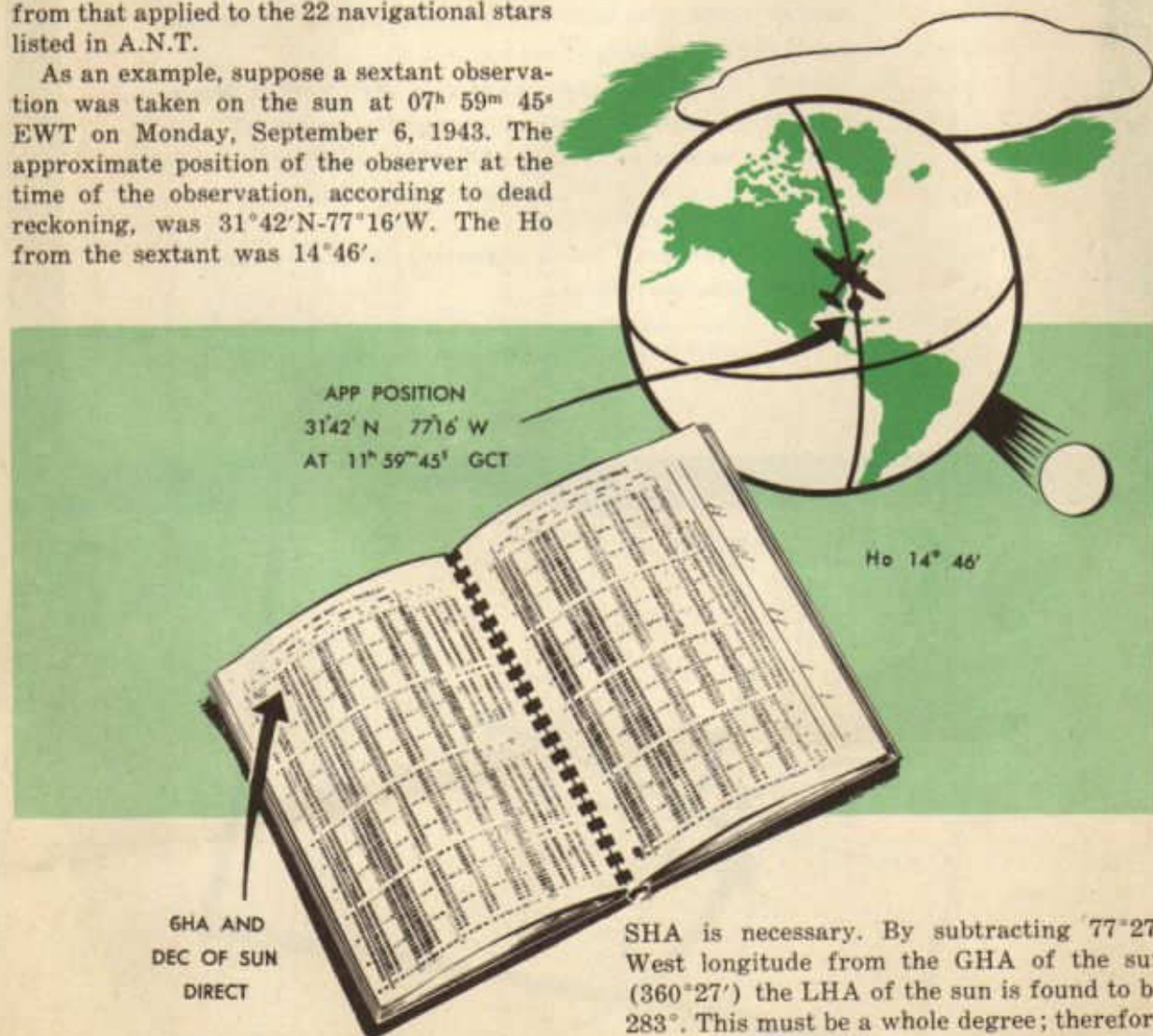

SHA is necessary. By subtracting $77^\circ 27'$ West longitude from the GHA of the sun ($360^\circ 27'$) the LHA of the sun is found to be 283° . This must be a whole degree; therefore the observer's position was assumed to be on the $77^\circ 27'$ meridian.

The latter (or declination) part of Volume G, *Astronomical Navigation Tables*, is used for the remaining calculations. Since the declination of the sun was found to be $N6^{\circ}40'$, the 6° declination table is located. The remaining $40'$ of declination will be considered later. The selection of the proper 6° table depends upon whether or not the declination is the *SAME* name as latitude. In this case,

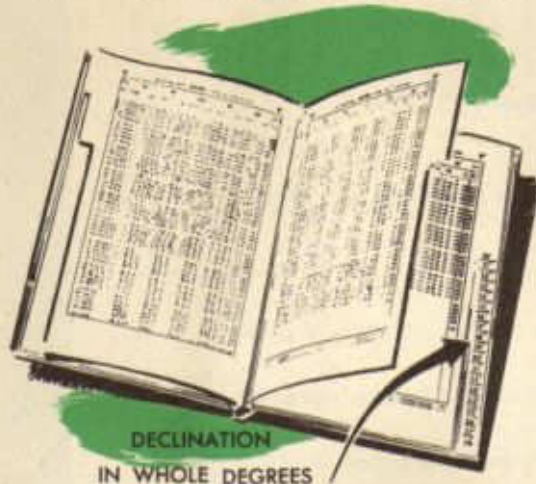

declination is north and latitude is north; therefore declination is the same name as latitude.

The arguments for entering the table are 283° LHA and $32^{\circ}N$ latitude. Altitude ($14^{\circ}15'$) and azimuth (092) are obtained as usual, but the altitude must be corrected for the additional $40'$ of declination. Between the altitude and azimuth a "d" correction ($+31$) is noted. This becomes one of the arguments for entering the table inside the back cover of the book.

The other argument is, of course, the remain-

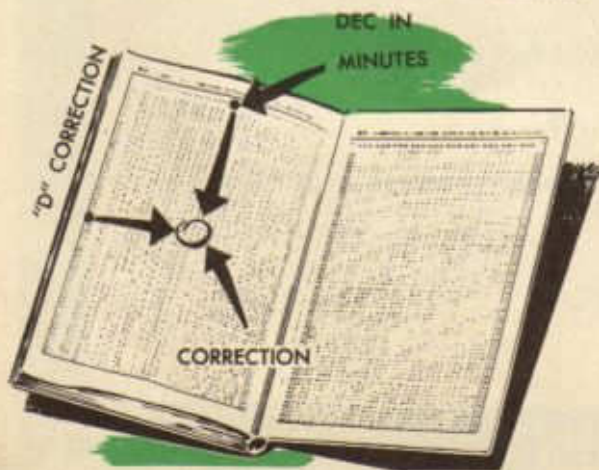

ing minutes of declination ($40'$ remaining from $6^{\circ}40'$). Using these two arguments the correction of 21 is found. This correction is applied to the altitude ($14^{\circ}15'$) according to the sign of d ($+$ in this case) to obtain H_c ($14^{\circ}15' + 21$ or $14^{\circ}36'$). By comparing H_o and H_c the intercept is found to be 10 miles toward the sun as measured along the azimuth from the assumed position ($32^{\circ}N-77^{\circ}27'W$). At this point the LOP is drawn perpendicular to the azimuth. Thus, at the time the observation was taken the observer was located somewhere on this line of position.

The almanac contains Greenwich Hour Angles (GHA) for visible planets and the moon in addition to those for the sun and Aries. Thus, lines of position may be calculated from observations on the moon and planets by exactly the same procedure as that used when observing the sun. Also, this method of solution must be used for all stars with declinations less than 29° not included in the 22 selected stars.

Since the moon is so near the earth, an additional correction must be applied to the observed altitude (H_o). This correction is called *parallax*. The last column on each right hand page of the almanac records corrections for various altitudes. The method of solution remains unchanged except for the addition of this correction to H_o before determining the intercept.

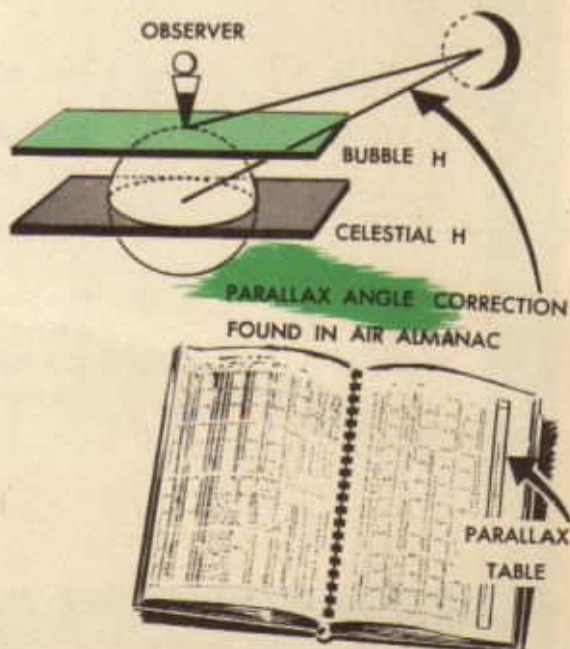

BODY: Sun	Ho: 14°46'	DATE: 9-6-43	TIME: 07 ^h 59 ^m 45 ^s EWT
1. GCT	11-59-45	EWT plus 4 hours	
2. GHA Sun	357°51'	From almanac opposite 11 ^h 50 ^m GCT See step 7 below.	
3. Corr.	2°26'	From Interpolation of GHA table for 09 ^m 45 ^s	
4. GHA Sun	360°27'	Step 2 + Step 3	
5. Long.	77°27'W	Adjusted to make LHA Sun a whole degree	
6. LHA Sun	283°00'	Step 4 + Step 5. West longitude; remember?	
7. Dec.	6°40'N	From Almanac. Nearest recorded declination to 11 ^h 59 ^m 45 ^s GCT	
8. Lat.	32°00'N	Nearest whole degree of latitude	
9. Az.	92°	From A.N.T. Vol. G. Declination 6° division. Follow rule for north latitudes at bottom of page.	
10. $\Delta d(\pm)$	+31	From A.N.T. Vol. G. Arguments: LHA 283° and Lat. 32°	
11. Alt.	14°15'	From A.N.T. Vol. G.	
12. Corr.	+21	From table inside back cover. Arguments: Δd +31 and 40' (from 6°40' - 6°00')	
13. Hc	14°36'	Algebraic sum of Step 11 and Step 12.	
14. Ho	14°46'	Observed altitude	
15. Inter.	10' Toward	LOP plotted 10 miles from assumed position toward sun along azimuth	

Plotting the Line of Position

The solution of the astronomical triangle by H.O. 218 supplies the information necessary for plotting the line of position. The LOP is represented as a straight line tangent to a circle of equal altitude, and it is drawn perpendicular to the *azimuth* or direction of the observed celestial body at the *intercept* distance toward or away from the assumed position. The use of a straight line instead of the actual circle of equal altitude enables the LOP to be drawn easily with negligible error.

As facility is gained in the actual plotting of the line of position, it will become evident

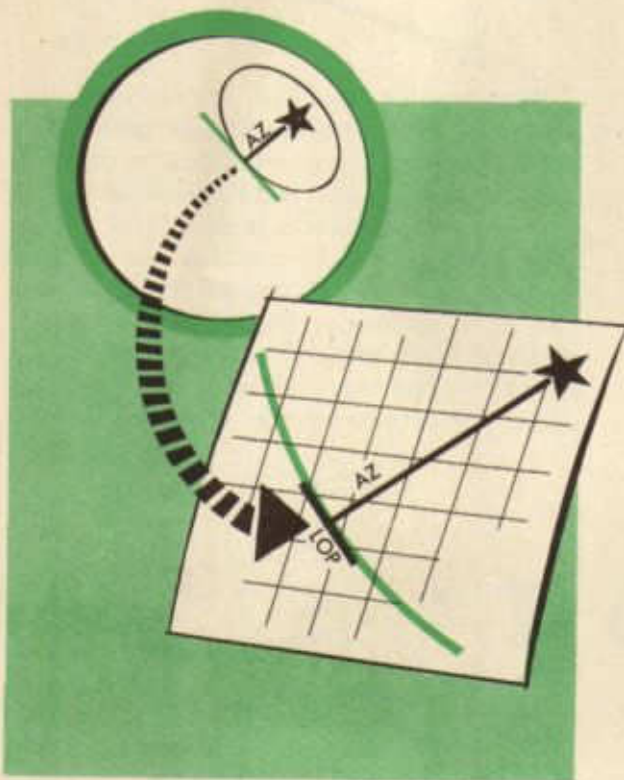

that quick, accurate shortcuts are possible. A short line drawn at the assumed longitude across the proper latitude will suffice for the assumed position. Drawing of the azimuth may be eliminated by placing one point of the dividers, with the proper intercept span, on the assumed position and using the plotter to indicate the azimuth through the assumed position. The intercept may now be spanned by the dividers along the bottom edge of the

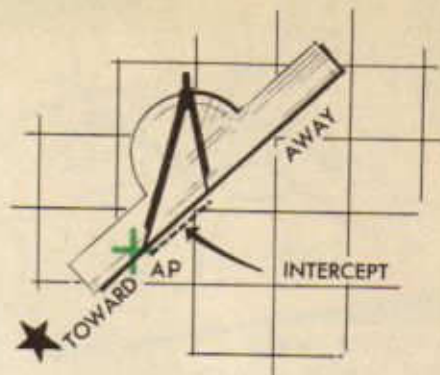

plotter toward or away from the celestial body in relation to the assumed position. At this point the LOP must be erected perpendicular to the azimuth. This may be done easily by simply following the directions in the illustrations.

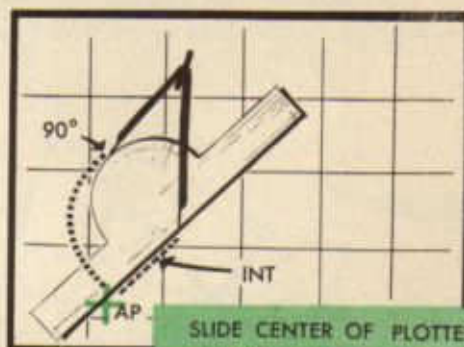

SLIDE CENTER OF PLOTTER TO DIVIDER ARM AWAY FROM AP AND MOVE DIVIDER ARM ON AP TO 90° MARK ON PLOTTER

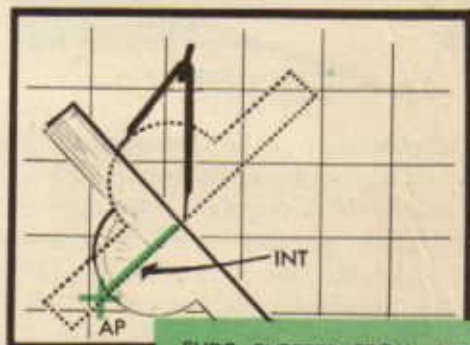

SLIDE PLOTTER FROM BETWEEN DIVIDERS AND SET BOTTOM OF PLOTTER AGAINST DIVIDERS LEG

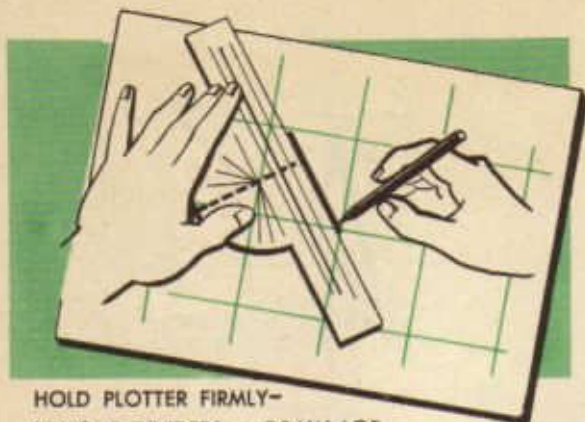

HOLD PLOTTER FIRMLY—
REMOVE DIVIDERS - DRAW LOP

The line of position is drawn along the bottom edge of the plotter, and in the interests of neatness it should not ordinarily be more than 60 NM long. If a sharp pencil is used, a neat, fine-lined LOP will result. Accurate, neat plotting and labeling of time and body are necessary when ground speeds are desired. Labeling of the LOP with its source and time reduces the amount of time spent in referring to the data as recorded in the log.

the track of the aircraft in relation to the true course increases. A line of position parallel to the true course provides the best indication of the aircraft's track.

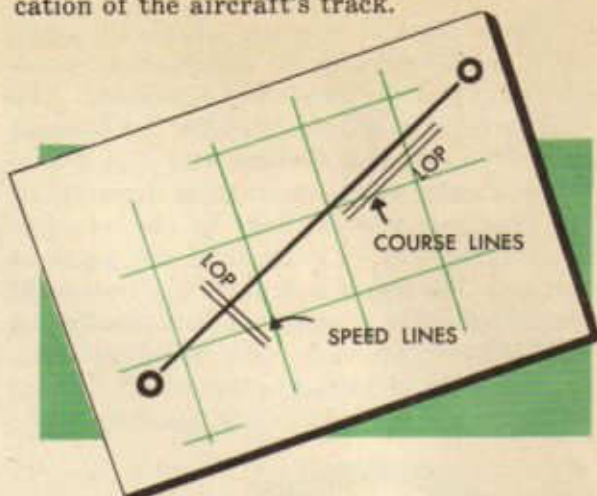

Map reading used in conjunction with lines of position provides the navigator with a wealth of material for directing the aircraft to destination. Drift reading can be used to keep the aircraft on course. Visual and celestial lines of position can be used to check each other or crossed to fix the position at a particular instant. Groundspeeds obtained from lines of position can be used to indicate the time of arrival over a checkpoint. Indications of the track of the air-

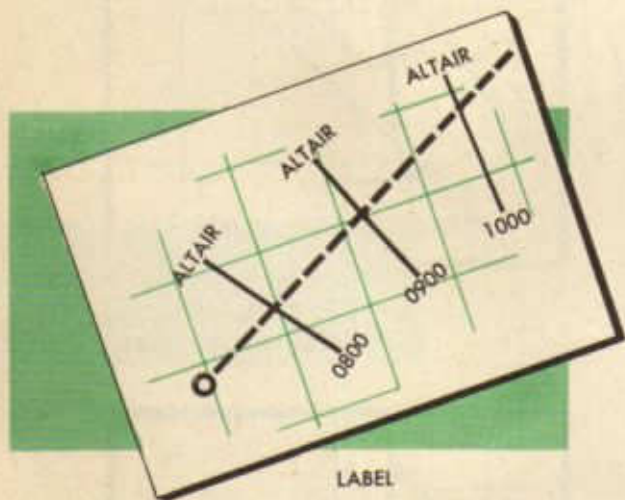

LABEL

Lines of position may be plotted at various angles ranging between perpendicular and parallel to the true course of the aircraft, depending upon the position of the celestial body. A line of position perpendicular to the true course provides the best indication of the aircraft's speed. As it tends more and more toward the parallel of the true course its use as a speed line diminishes, but at the same time its usefulness as an indication of

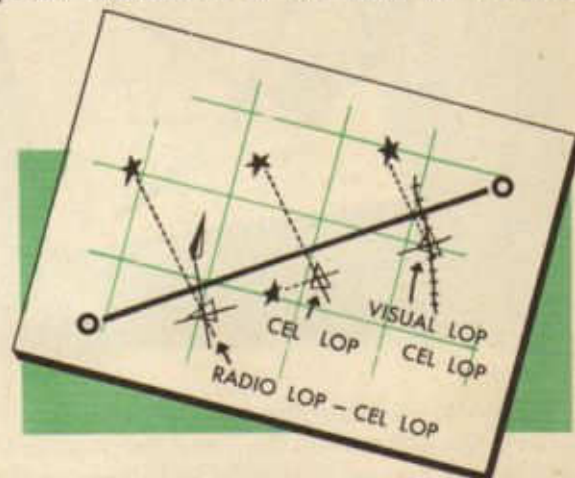

craft obtained from lines of positions can be used to indicate where to look for checkpoints. Radio lines of position can be used to supplement celestial observations. With this information the navigator can determine the position of the aircraft at any instant as well as direct it to destination.

USING THE LINE OF POSITION IN SIMPLE PROBLEMS

Sextant Check

The greatest problem in the use of the sextant is concerned with alignment. Unavoidable bumps and jars continually upset the delicate mechanism; however, since the error usually is very small there is no need for completely reconditioning the instrument. It is necessary only to know the error in order to use the sextant to determine an accurate Ho.

The error may be determined in several ways. Curves of the altitudes and azimuths of a celestial body as viewed from a known position over a definite period of time may be drawn and compared to actual observations.

If a large body of water is nearby, the natural sea horizon can be used as a reference. After determining the exact height of the sextant above the water level, dip correction (from almanac) can be *added* to the sextant reading obtained by splitting the bubble with the sea horizon, and the difference between the corrected sextant reading and zero is the sextant error. The error can be determined mechanically by use of the collimator. The crosshairs, or "star," of the collimator are superimposed on the sextant bubble and the instrument reading is taken. If the scale reads above zero, the error is plus; if below zero, it is minus.

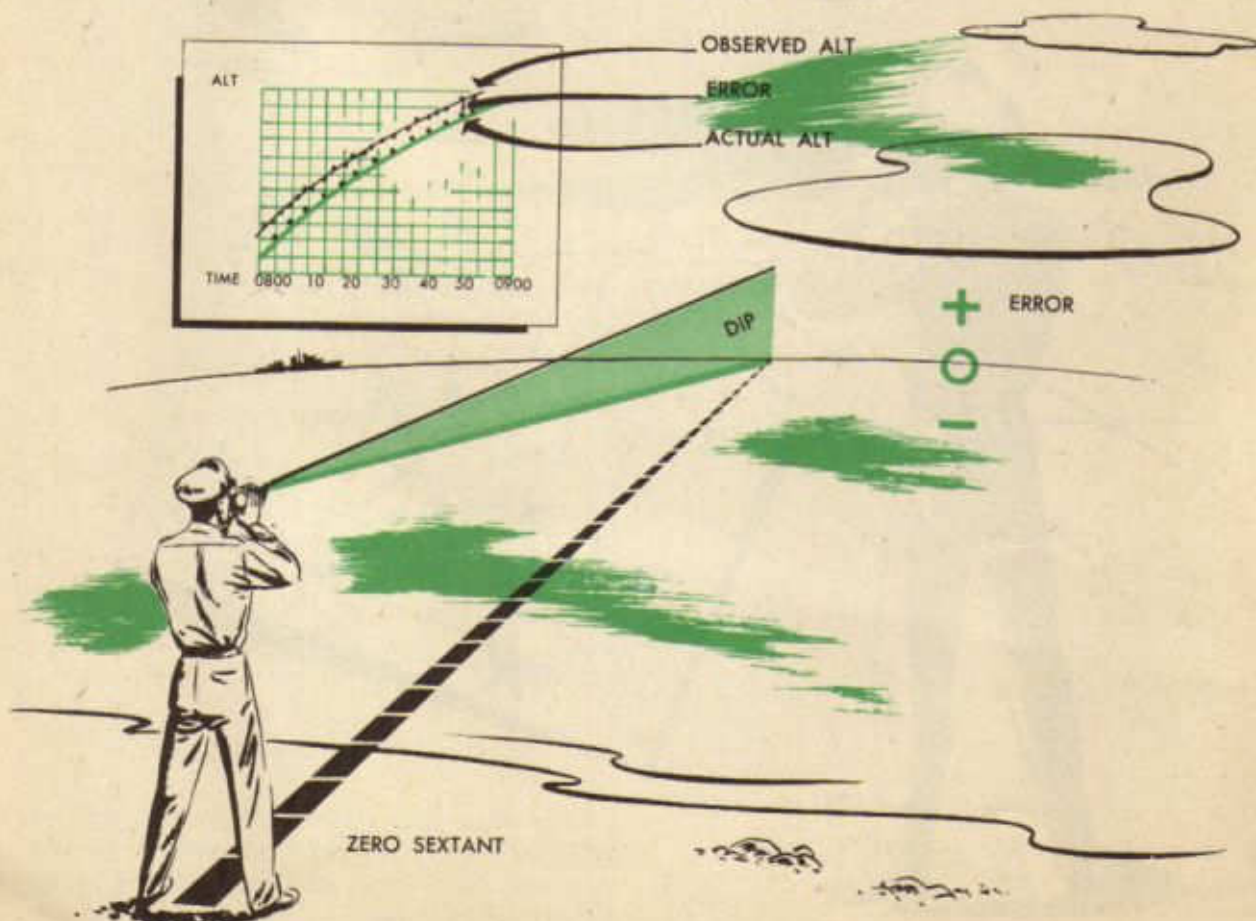

Probably the simplest method of checking a sextant, however, is by actually plotting lines of position determined by H.O. 218. Exact time as well as latitude and longitude must be known. If the sextant is correct and has been used properly, and if the time of the observation is accurate, the LOP will fall through the known position of the observer. If the LOP does not pass through the observer's position, the instrument must be in error. The amount of the error is equal to the perpendicular distance between the LOP and the position of the observer. This distance measured in nautical miles is expressed in minutes of arc. If everything is exact except the sextant, the error can be found by plotting a number of lines of position and taking the average. This average must be added or subtracted from the sextant altitude to obtain the correct Ho.

The sign (+ or -) of the correction may be determined by the relationship between Hc and Ho. When the LOP falls closer to the subpoint (in the direction of the azimuth) than the *actual* position, the correction is always minus. This means that the intercept is too small; therefore it must be increased by making the Ho smaller so that the difference between Hc and Ho will be greater. When the LOP falls farther away from the subpoint (along the reciprocal of the azimuth) than the *actual* position, the correction is plus. In this case the intercept must be made smaller by enlarging the Ho.

The sextant may be easily checked by this method, and in the interest of safety it should be tested before each flight. The cor-

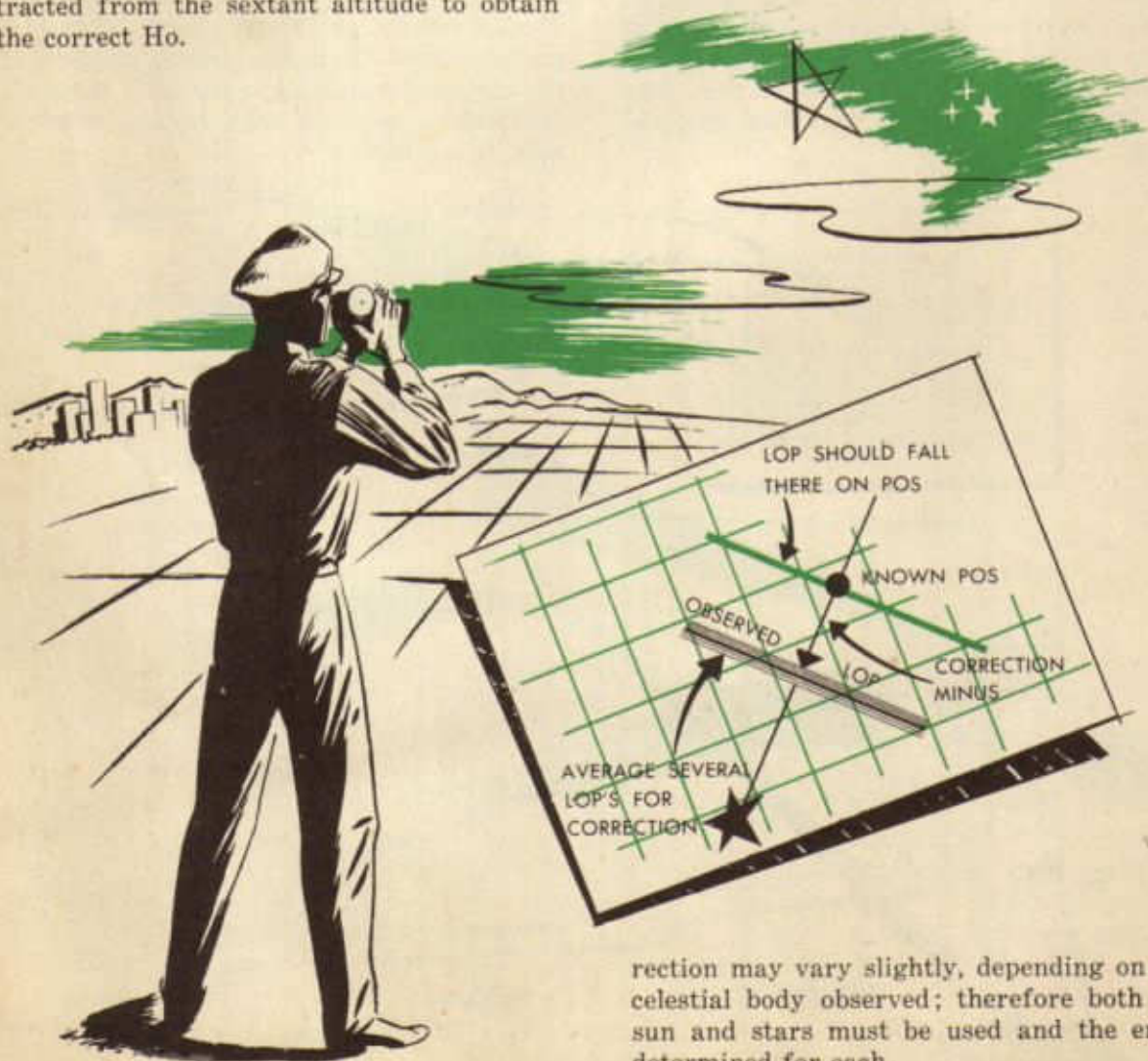

rection may vary slightly, depending on the celestial body observed; therefore both the sun and stars must be used and the error determined for each.

Latitude by Polaris

The latitude of a place equals the altitude of the elevated celestial pole. Therefore, if the north star, Polaris, were exactly at the North Pole (Declination 90°), its corrected observed altitude would equal the latitude in the northern hemisphere. However, Polaris is not at the North Pole, although it is nearly so. It moves about the pole, as do other stars, in a circle which at the present is never more than $61'$ of arc in radius. Since the circle is relatively small, Polaris can be used as an indication of the elevated pole by simply applying a small correction to the sextant

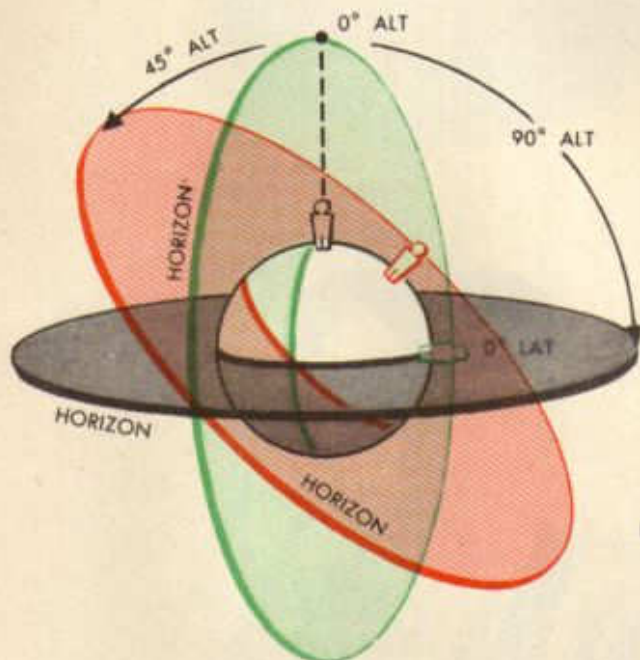

ALTITUDE OF POLE = OBSERVER'S LAT.

altitude. The amount of this correction depends upon the location of Polaris in relation to the observer's meridian. Obviously, when the star is higher in the sky than the elevated pole the correction must be subtracted. When it is at the same altitude on one side or the other of the north celestial pole, the correction is zero. The correction is added when Polaris is below the pole.

A rough estimate of the amount of correc-

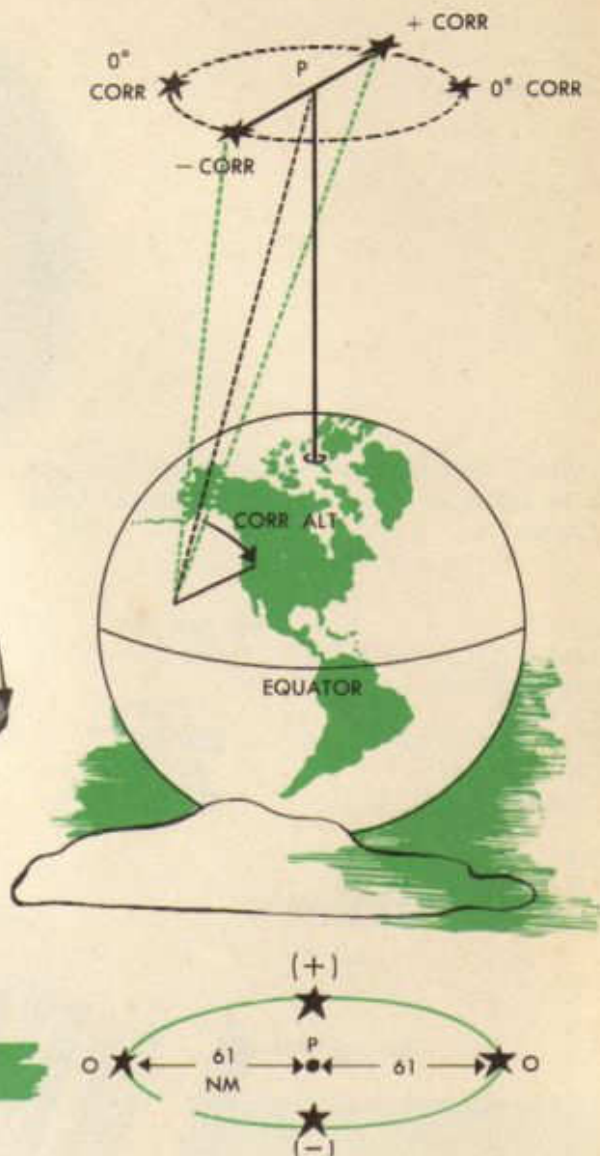

tion and its sign can be obtained from the fact that the north celestial pole is always approximately between Polaris and the two pointer stars in the Big Dipper constellation. The exact correction to be applied to the observed altitude can be obtained from a table on the back of the star chart in the *American Air Almanac*. In order to eliminate the solution of right triangles, the LHA \uparrow is calculated for the time of the

observation and used to enter the table. Corrections range from zero to $\pm 61'$ for the local hour angles of Aries throughout 360°

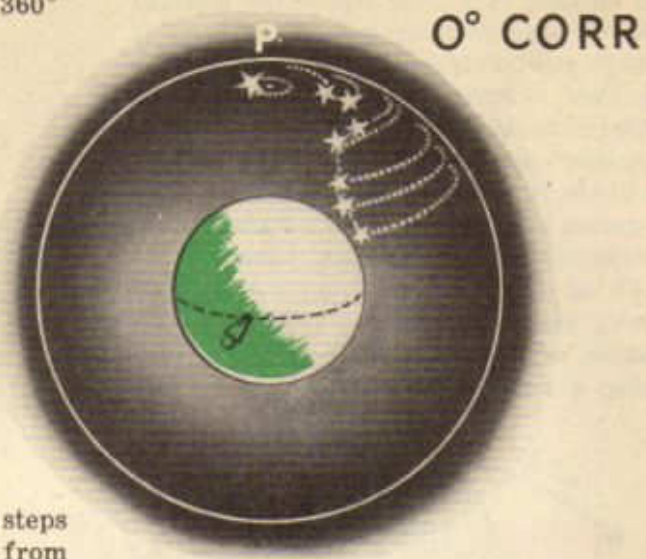

The following problem indicates the steps to be followed when obtaining latitude from Polaris:

GCT	02 ^h 04 ^m 27 ^s
GHA Υ (GCT 0200)	224° 57'
Interpolation for 4 ^m 27 ^s	1° 07'
GHA Υ (GCT 02 ^h 04 ^m 27 ^s)	<u>226° 04'</u>
DR longitude	21° 42' W
LHA Υ	<u>204° 22'</u>
Ho	53° 09'
LHA Υ Corr.	+1° 01'
Latitude	<u>54° 10' N</u>



AIR ALMANAC

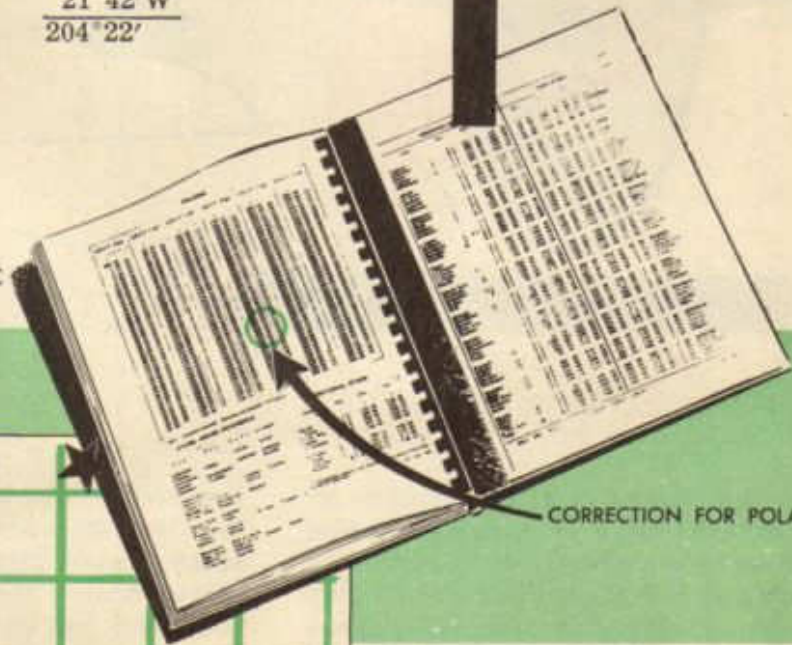

CORRECTION FOR POLARIS

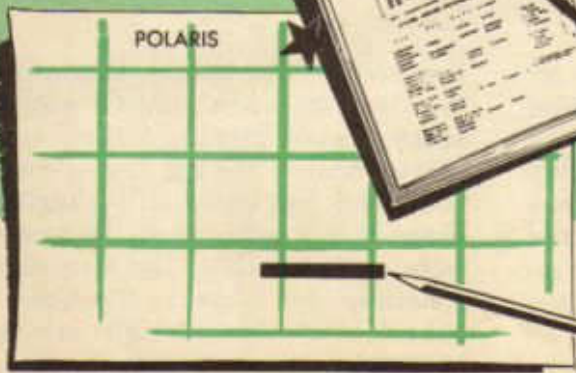

POLARIS

DRAW LOP OF POLARIS
AS A LAT LINE—NO
AZIMUTH NEEDED

The Landfall

The landfall is a particularly important aspect of aerial navigation. It provides a means for the navigator to reach destination by flying on a line of position advanced through destination. It is very valuable when only one body is visible, although it may be used when any number of bodies are visible. It may also be used at the end of a long flight when the accumulated error cannot be determined.

The simplest example of a landfall involves map-reading and visual LOP's. In the following diagram imagine the railroad running through a desert to destination.

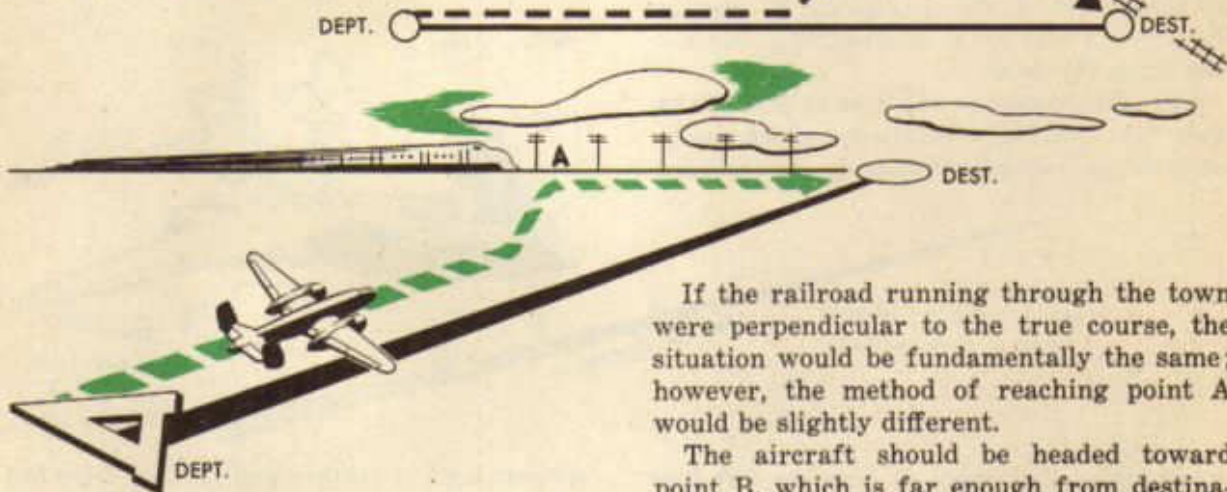

Without worrying about groundspeed and ETA, what would be the best method which could assure arrival at destination? Obviously, if the aircraft were placed on the railroad at or about point A, it could be flown along the "iron beam" until destination was reached. In this case the railroad is the locus for all possible points where the aircraft could be at the particular time. In other words, it is a line of position through destination, and the only navigation problem involved is that of staying on the LOP until destination is reached. Care must be taken to place the aircraft over the railroad before passing destination. This assures knowledge of the direction in which to turn to reach destination.

If the railroad running through the town were perpendicular to the true course, the situation would be fundamentally the same; however, the method of reaching point A would be slightly different.

The aircraft should be headed toward point B, which is far enough from destination to assure knowing which way to turn upon arriving at the railroad. Any means may be used to determine an ETA at the

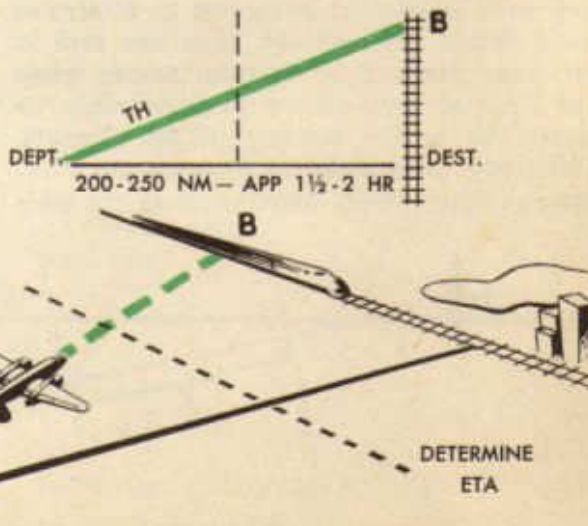

railroad, but, for simplicity, assume another railroad at the dotted line in the diagram. The information gained from this LOP may be used to estimate time of arrival at the LOP paralleled through destination.

From these simple explanations it may be deduced that landfall procedure involves (1) the taking of one or more LOP's, (2) advancing an LOP through destination, (3) using the information gained from the one or more LOP's to navigate the aircraft to the LOP advanced through destination at the earliest practical moment, and (4) keeping the aircraft on this LOP by continued observations until destination is reached. It must be remembered at all times that the landfall is worthless unless the navigator is certain from which side he is approaching destination along the LOP.

With these rules in mind, it is possible to study the various situations which arise when flying landfalls. It must be remembered



at all times that lines of position fall into two extreme categories, and any degree of variation between the two extremes is possible.

When lines of position fall in such a manner as to enable the navigator to determine an accurate groundspeed, they are said to be *speed* lines. This situation occurs when the lines of position are perpendicular, or nearly so, to the heading of the aircraft. Obviously the matter of interpretation becomes of paramount importance as the lines

of position fall farther and farther from the perpendicular. Many varying factors influence this interpretation.

The following diagram indicates the proper procedure to follow when flying a landfall using speed lines. When the aircraft is navigated to a point about 200 or 250 NM or 1½ to 2 hours from destination, it must be turned to one side in order to know definitely which direction to turn upon arrival at the LOP through destination. The maximum error (DE) to assume under normal condi-

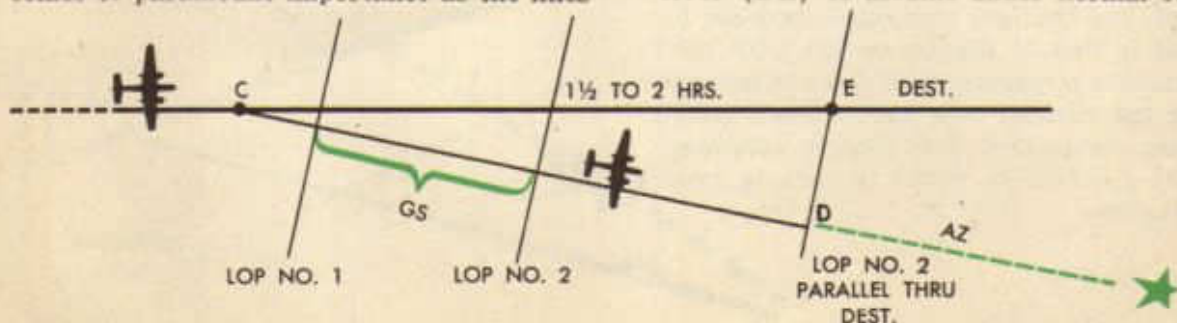

tions is 40 to 50 miles over a distance of 200-250 NM. By flying a heading approximating the azimuth or its reciprocal, yet far enough off course to allow for the assumed error, the aircraft flies the shorter distance.

After deciding on the heading to fly from point "C," the navigator is faced with the problem of determining the groundspeed. This may be done by lines of position starting about half an hour from point C. There are several variations which may be used to obtain accurate information for plotting the line of position. Two or more observations can be taken close together and the arithmetic average of time and H_0 used to plot one LOP.

At times it may be desirable to plot each LOP taken over a short period of time. If this is done, an average can be obtained by moving the first LOP by best information along the true course to the time of the last

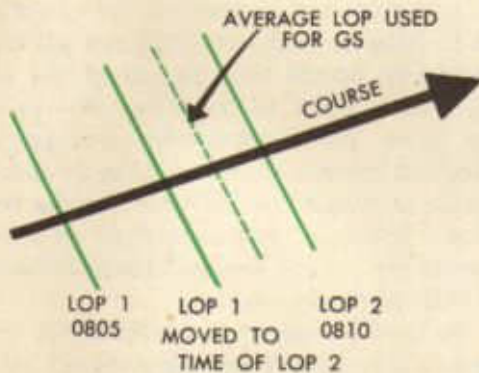

and visually draw an average. The advantage of these methods lies in the fact that only one measurement is needed to determine groundspeed. However, in spite of this, many navigators prefer to plot the results of each observation in order to obtain as many groundspeeds as possible.

Regardless of the method used to establish a line of position, the greatest problem is con-

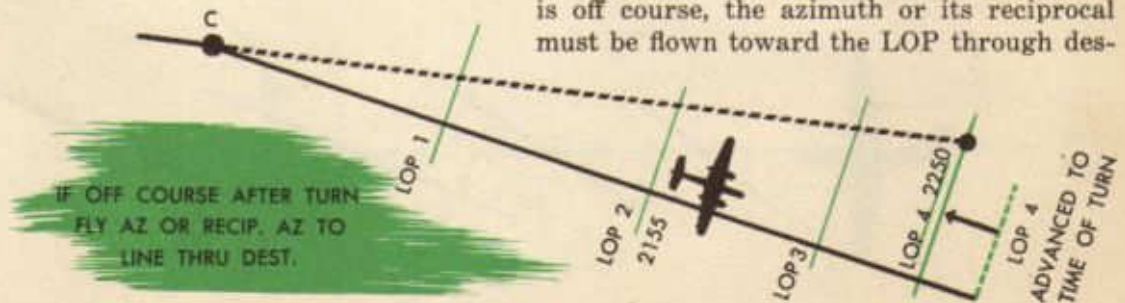

cerned with the determination of the time to turn on an LOP paralleled through destination. The LOP selected to advance through destination depends upon the interpretation



ETA TO LOP MAY BE COMPUTED ALONG EITHER ORIGINAL TC OR ALONG ASSUMED TRACK. THE 2 TIMES WILL BE THE SAME.

of the lines of position taken during the flight, but each interpretation is based on the fact that a line passed through a triangle parallel to one side divides the other two sides in the same ratio.

A simple and practical method of flying a landfall utilizes the groundspeed obtained from the last LOP to determine the ETA to that LOP paralleled through destination. Lines of position are taken as usual in order to keep station as well as to evaluate the last LOP. Obviously, much depends upon the accuracy of the last LOP; therefore the average of several observations taken over a short period of time is usually used to establish this position. This last LOP is taken at a time which allows a sufficient period for the calculations and chart work necessary to determine the ETA to its parallel through destination. The accuracy of this ETA is checked again by observations immediately before and after turning on the advanced LOP toward destination.

Lines of position taken after the turn fall parallel or nearly so to the true course of the aircraft. If it is ascertained that the aircraft is off course, the azimuth or its reciprocal must be flown toward the LOP through des-

tion. The best available information, usually TAS, is used to determine when this LOP has been reached. Care must be taken, however, when weighing these lines of position. It must be remembered that speed line observations are relatively easier than observations taken abeam of the aircraft; therefore, information gained before turning on the last LOP paralleled through destination must not be outweighed by material gained from an insufficient number of course line observations.

It has been mentioned several times that the navigator must be careful to assume an error which will place the aircraft definitely on one side of destination. The amount of this assumed error depends on the maximum possible navigation error. The direction of flight is determined by the azimuth of the LOP through destination.

In the accompanying diagram the navigator calculates the aircraft to be at C and his maximum error to be CE. The azimuth of the body being used is indicated by the dotted line DX; therefore, the desired heading of the aircraft during the landfall approximates the reciprocal of this azimuth. A

glance is sufficient to show that by turning off to the right, the LOP will be reached sooner than by turning off to the left. The exact heading of the aircraft may be determined by measuring OD equal to the assumed error CE and drawing CD. Now, suppose the aircraft were actually at E instead of C. By flying the heading EO, which is parallel to CD, it would arrive at the LOP over destination. If the aircraft were actually at E' it would arrive at O'. This would result in flying a much longer time along the LOP before reaching destination, but the navigator would know which way to turn upon arrival at the LOP. Thus, the assumed error must be the maximum navigation error in order to place the aircraft definitely on one side of destination.

In the discussion of the speed line landfall it was noted that the aircraft was placed on an LOP through destination; therefore, observations with the aircraft on this heading result in lines of position which are parallel, or nearly so, to the true course of the aircraft. These lines of position are called course lines. The fundamental concepts of the landfall remain unchanged regardless of the angle at which the LOP crosses the true heading; however, the procedure required for use of the course line is slightly different from that of the speed line.

In the landfall using course lines, the fundamental idea is to place the aircraft along an LOP paralleled through destination. The difficulty with course lines lies in the fact (1) that the observations are less accurate, and (2) that the wind effect is more noticeable. Fact number one (1) may be offset somewhat by making observations while flying the azimuth to the LOP through destination.

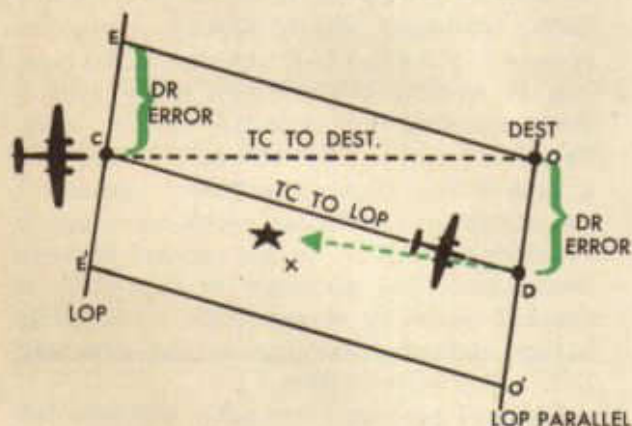

LOP 3 FROM OBSERVATION WHILE FLYING AZ

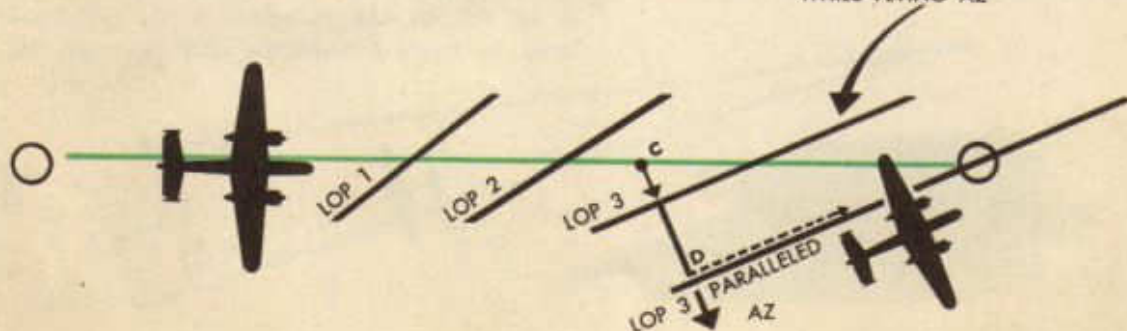

This procedure is explained in the diagram. It must be noted that the lines of position cut the true course at a sharp angle; therefore, it is practical to place the aircraft on the LOP paralleled through destination shortly after departing. As the angle increases it becomes necessary to fly closer to destination before turning off to get on the LOP. This becomes a matter of interpretation, especially since groundspeeds cannot be accurately determined from course lines. Lines of position No. 1 and No. 2 are taken for practice. It is decided that it is practical to fly over to the LOP through destination rather soon after departing; therefore the aircraft is calculated to be at C by the best available information. Using coordinates of point C, predetermine the azimuth. At point C the aircraft is turned on the heading CD, which parallels the azimuth or its reciprocal.

After turning at point C, an LOP is obtained immediately. Since the aircraft is flying on the azimuth, the LOP obtained will be

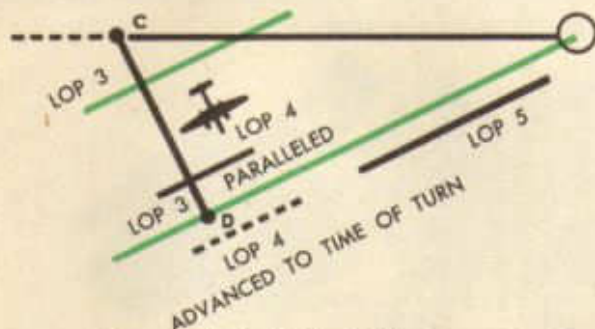

a speed line and should be fairly accurate. In the diagram this is LOP No. 3. Parallel No. 3 through destination and obtain an ETA by DR, metro, or TAS to point D. The distance used to determine this ETA is between LOP No. 3 and LOP No. 3 paralleled and not from point C.

Just before the ETA to the No. 3 paralleled is up, another LOP should be obtained in order to double check the position of the aircraft. This LOP will also be a speed line.

AFTER TURN TO DESTINATION
**DON'T STOP
 NAVIGATING**

Advance this LOP to the time of turn, and check the aircraft's position in relation to the LOP paralleled through destination. If the azimuth of the body is changing rapidly, it may be desirable to parallel the last LOP through destination in order that future observations will be more nearly parallel to the true course. In any event, the azimuth or its reciprocal must be flown to the desired LOP.

It must be noted that the wind may consistently blow the aircraft from the LOP through destination; therefore, constant checking is necessary. Occasionally, it may be desirable to make observations when the aircraft is on the LOP instead of the azimuth, but care must be taken to realize the danger of inaccurate shots due to the motion of the aircraft. Ordinarily the azimuth of lines of position change markedly before destination is reached; therefore, it may become necessary at times for the navigator to parallel additional LOP's through destination and fly azimuths in order to interpret his observations properly.

Finally, at times, landfalls which start out with course lines end with speed lines, or vice versa. Much of the confusion which results from this situation may be eliminated by computation of an azimuth for a TAS ETA at destination. This will serve to provide a basis for planning the landfall before it is actually flown.

CHECK BY ADDITIONAL OBSERVATIONS
 TO SEE IF YOU ARE STILL ON
 LOP THRU DESTINATION



SOME THEORY BEHIND THE LINE OF POSITION

Star Identification

It is essential for a navigator to recognize the principal navigation stars in clear weather at sight. This is done by a knowledge of the relative positions of these bodies, their movements, and enough of their physical aspects to help distinguish between them and to recognize them individually.

When the weather is unfavorable, the navigator should be able to identify isolated stars peeping through rifts in the clouds by using star finders or star maps. Instructions for use are furnished with these devices. It is imperative that star maps be studied like ordinary maps, remembering the relative positions of the stars.



NAVIGATOR SHOULD BE ABLE TO IDENTIFY ISOLATED STARS

It is easy to visualize the positions of at least 24 large cities on the map of the United States. These cities are remembered in relation to the state and, finally, the state in relation to the country as a whole. This procedure can be applied to the problem of learning the stars. However, the names of stars must be remembered correctly, just as the names of cities must be remembered.



Identifying planets is still easier because only four of them are used in navigation, and no more than three are ever visible at any one time. The planets move with respect to the stars; therefore, once the relatively fixed pattern of the stars becomes familiar, an extra body in the group is easily spotted.

Most stars are distinguished from planets by their appearance as twinkling points of lights. Planets in general appear as small discs of steady light. Venus and Jupiter are brighter than any fixed star. Mars is usually distinguished by its reddish color. The angle between the sun and Venus as viewed from the earth is never more than 47° , which is equivalent to about three hours of time. Allowing for declination, the navigator cannot see Venus more than three hours before sunrise or three hours after sunset, except in high latitudes. When at or near its maximum brilliancy, it is easily seen in full daylight.

Cities within the United States are identified by a specific name and the name of the state of which it is a part. This serves to locate the city geographically. Likewise, stars are designated by an individual name and the name of the constellation to which it

belongs. Thus, for example, Rigel Orionis indicates the star Rigel in the constellation of Orion. These names have been derived from various sources. The constellations have Latin names conferred on them by early star gazers who saw in the stars some resemblances to legendary characters. Most of the individual stars within the constellations have Arabic names, although a few are Latin.

A more complete system for cataloging the stars uses Greek letters to designate the individual stars within a constellation. Generally, the sequence of lettering is in the order of brightness; the alpha (a) star being the brightest, the beta (b) star next, and so on. For instance, the bright star in the constellation Ursa Major (the Great Bear or the Big Dipper) nearest to Polaris is a Ursa Majoris; however, it is commonly known as Dubhe. Letters are applied to all stars in a constellation regardless of whether or not they already have specific names. Rigel Orionis, for example, is also known as B Orionis. Common names, such as Rigel and Dubhe, are much easier to remember; therefore the navigator usually becomes acquainted with the stars by these designations.

The degrees of brightness of a star is called magnitude, and it is expressed as a numeral and a decimal fraction which varies inversely as the brightness. The brighter the star the lower the numeral index of magnitude. Sixth magnitude stars are just barely visible to the naked eye, while the brightest of all stars, Sirius, has a magnitude of -1.6 , the negative sign indicating a brilliance even greater than that of regular first magnitude stars.

Probably the best way to learn to identify the stars on sight is to observe the stars on a clear night and to check their relative positions and names against a star chart. The accompanying charts or the one in the back of the *American Air Almanac* are excellent for this purpose. The accompanying charts have been divided into several sections revealing the most prominent stars and constellations visible during the four seasons of the year. Of course, much overlapping occurs, but this is a convenient method of referring to various sections of the heavens.

The general procedure for learning each section (omit polar projections) is to start with a conspicuous constellation and to learn how to identify the major navigation stars in it. Then, the next step is to proceed north or south by projecting imaginary straight or slightly curved lines through two or more known stars to establish the position of an unknown star. The patterns set up by these lines should be simple geometric figures. Although their shapes are unimportant, they should run in a general north and south direction because an east-west pattern may include a star which at certain times may have set or not yet risen.

Dipper. An observer using the north polar chart at 30° north latitude will find that some of the stars at the edge of the chart opposite the observer have set beyond the horizon. Zenith can be located on the hour circle running up from the pole, and the stars on the edge of the chart near zenith will be behind the observer.

The five projections extend from 65° N to 65° S and each covers 90° of SHA. The outlines of major constellations are indicated by black dash lines. Important navigation stars

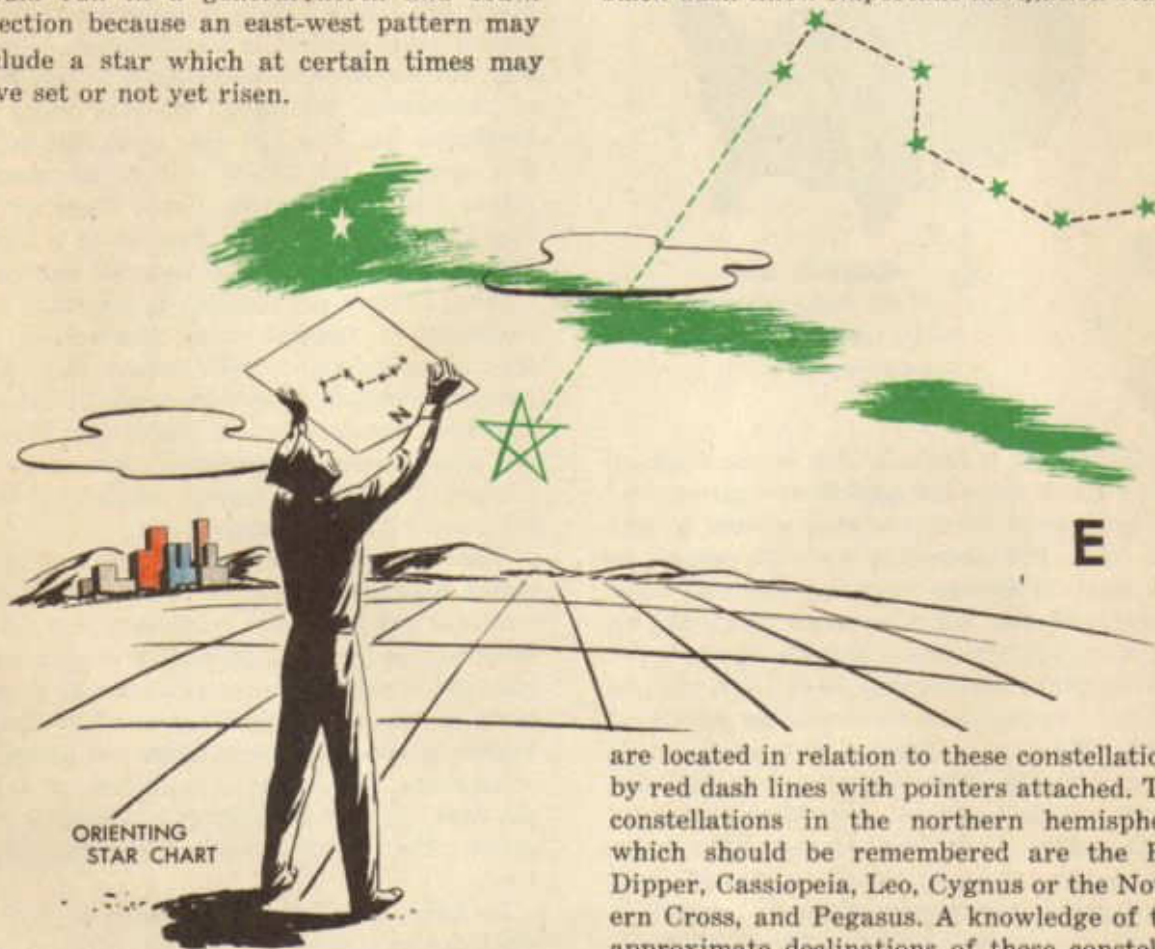

are located in relation to these constellations by red dash lines with pointers attached. The constellations in the northern hemisphere which should be remembered are the Big Dipper, Cassiopeia, Leo, Cygnus or the Northern Cross, and Pegasus. A knowledge of the approximate declinations of these constellations in relation to the observer is very helpful. The constellations in the southern hemisphere to remember are Scorpio and the Southern Cross or Crux. The most beautiful constellation in the heavens, Orion, is located on the equator extending 10° to each side. The 55 navigation stars listed in the Air Almanac can be located by pointers radiating from these major constellations. The 22 navigation stars listed in the A. N. T. H.O. 218 books are underlined on the charts.

The accompanying charts are oriented with east to the left and west to the right. In this manner they represent an inverted picture of the sky; therefore the stars will appear in their true perspectives if the charts are held overhead with the north edge toward the north pole.

Generally a polar chart is best used by facing the pole and rotating the chart until it is correctly oriented with reference to some outstanding constellation such as the Big

Motions of Heavenly Bodies

Observation of the sky reveals several important facts which must be thoroughly understood before the theory of celestial navigation can be fully comprehended. On any clear night the observer is confronted with an enormous array of recognition points in the sky, and at first sight no movement can be ascertained. After repeated observations, however, it will be noted that, like the sun, stars appear to rise over the eastern horizon and descend toward the west. This motion of heavenly bodies is only apparent, however, since it is actually a result of the earth turning from west to east on its axis, but for explanatory purposes it will be assumed that it is the stars which have motion.

Continued observation of the moving bands of light reveals other interesting facts. Imagine two automobiles speeding side by side along a broad highway. Farm houses and fence posts appear to the occupants of each car to be hurrying by, but the automobiles do not seem to be moving since they remain side by side. Stars moving across the heavens maintain this same relationship to each other. Night after night stars remain side by side as they speed toward the west.

People of ancient times noted that stars grouped in a peculiar manner apparently retained the same configuration; therefore these constellations (for that is their technical title) were named for earthly things which they seemed to picture in the sky. A good example of this is the Great Bear, better known as the Big Dipper. There are many of these constellations in the sky, and it must be remembered that just as stars within each group remain in a definite pattern so do the constellations retain the same distance and direction from each other.

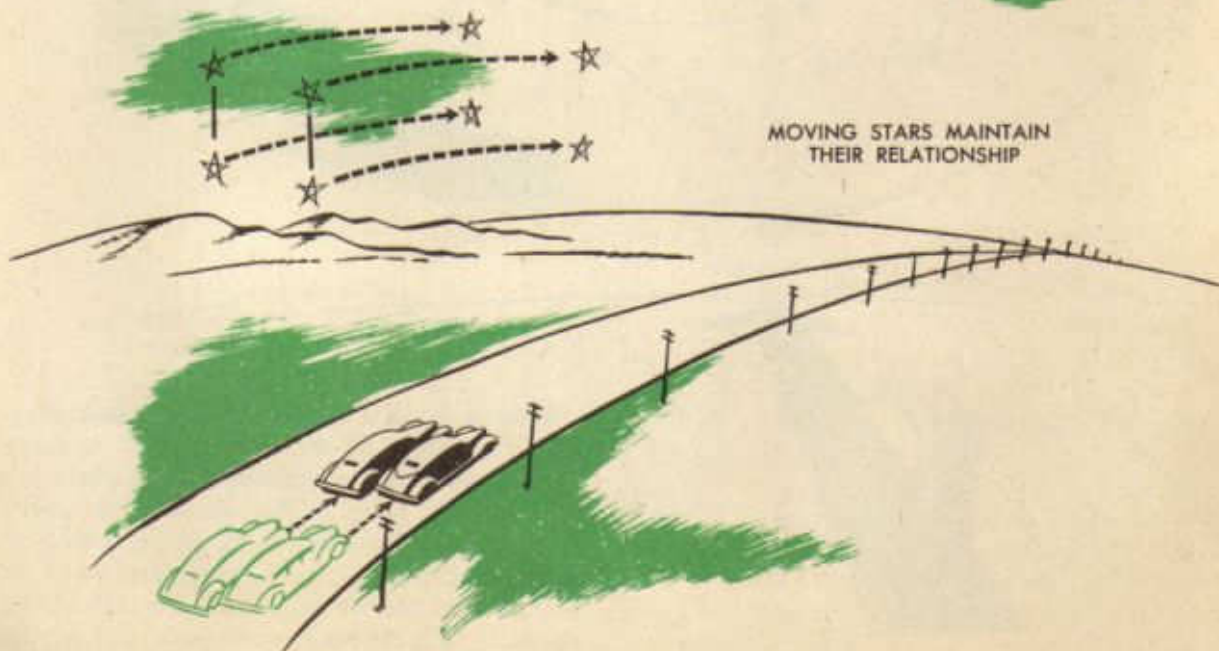

MOVING STARS MAINTAIN
THEIR RELATIONSHIP

In addition, to an earthbound observer each star follows a constant path night after night. For instance, as viewed from the United States during the winter months, a beautiful constellation appears each night slightly south of east. An observer familiar with the regularity of star movement can, therefore, locate this group of stars with ease.

If this constellation is viewed throughout the winter months, the observer will notice that as soon as it becomes dark enough for the stars to be seen they seem to be slightly higher in the sky than the preceding night. During the latter part of January the constellation is high in the sky almost due south when night falls. As spring approaches, this group of stars appears farther and farther toward the southwest until they cannot be seen when the sun sets.

This phenomenon indicates that stars rise over the eastern horizon earlier each night; therefore as the light from the sun diminishes, the stars have already begun their westward journey. It has been calculated that stars rise four minutes earlier each day;

therefore a day calculated by the movement of the sun (called a solar day) is longer than a day measured by the appearance of a particular star over the horizon (called sidereal day). A star or sidereal year (366.24 days) has approximately one more day than a solar year.

Another important concept which can be gained by merely looking at the stars-concerns their relationship to a stationary observer on the earth. Some constellations appear at nightfall due east of the observer, some appear directly overhead, some high in the sky to the south or north. In fact, stars may be seen in any direction. But continue to watch them throughout the night. Stars appearing due east seem to travel farther as they move directly overhead and settle toward the west. Stars to the north or south make smaller arcs across the hemisphere in the vision of the observer. Some stars far north or south make a complete circle within the field of vision. In the northern hemisphere a star (Polaris) will be seen constantly in one position with nearby stars moving in a circle around it.

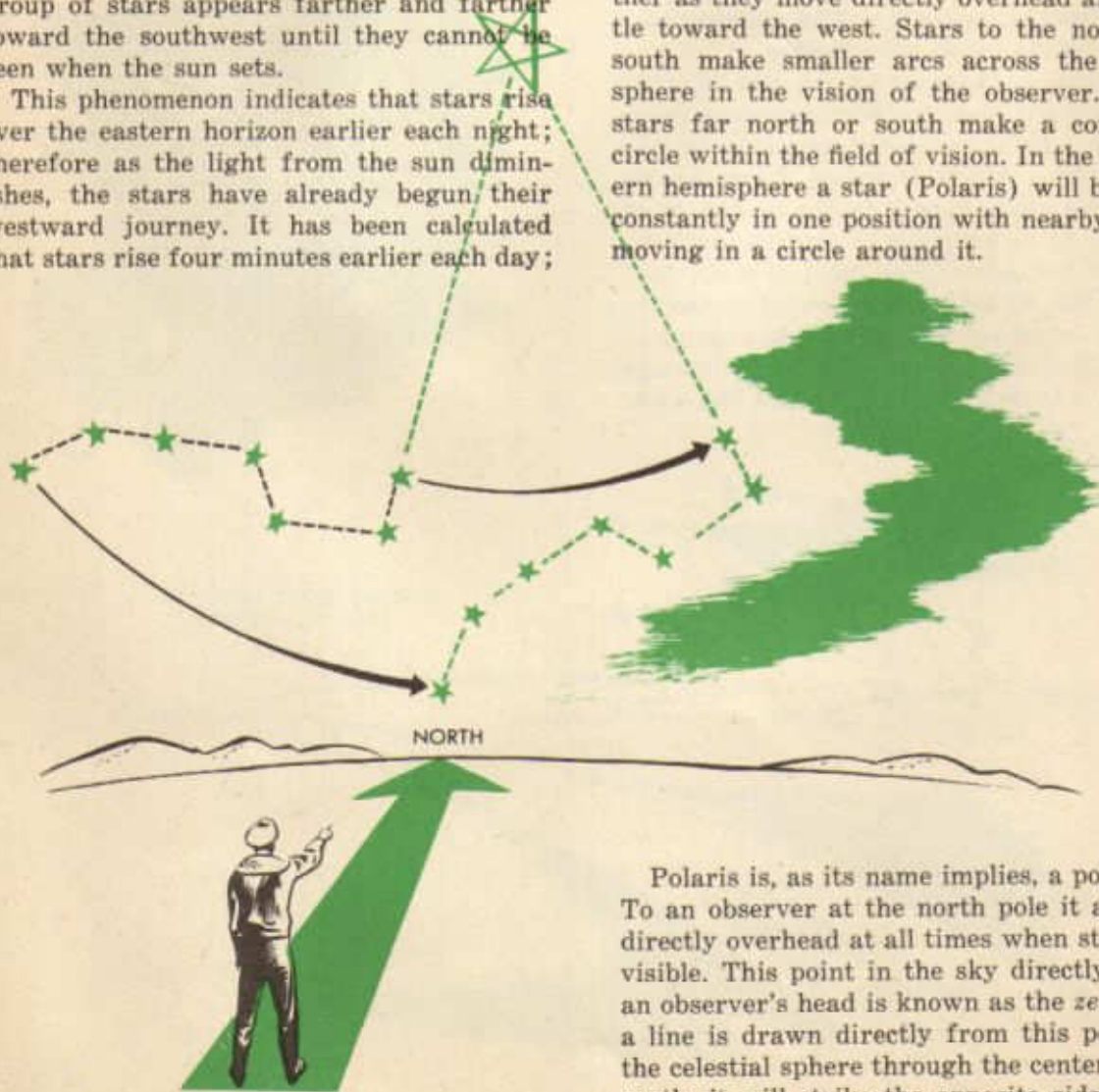

Polaris is, as its name implies, a pole star. To an observer at the north pole it appears directly overhead at all times when stars are visible. This point in the sky directly above an observer's head is known as the *zenith*. If a line is drawn directly from this point on the celestial sphere through the center of the earth, it will strike the opposite side of the

celestial sphere at a point called the observer's *nadir*. Thus, zenith and nadir are always 180° apart. As the observer changes position zenith and nadir move also.

For the moment it may be assumed that Polaris is directly over the north pole; therefore if it should drop straight toward the center of the earth it would strike the pole. The point at which it strikes is known as its *substellar point*, or simply *subpoint*. Thus, the point on the surface of the earth directly beneath any star is called the subpoint. Since at the moment it is understood that Polaris has no motion, it follows that its subpoint has no motion. On the other hand, the subpoints of bodies in motion are constantly changing.

POLARIS AT OBSERVER'S ZENITH

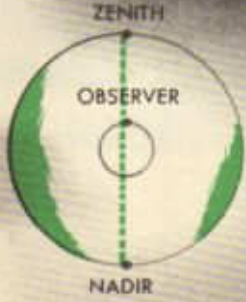
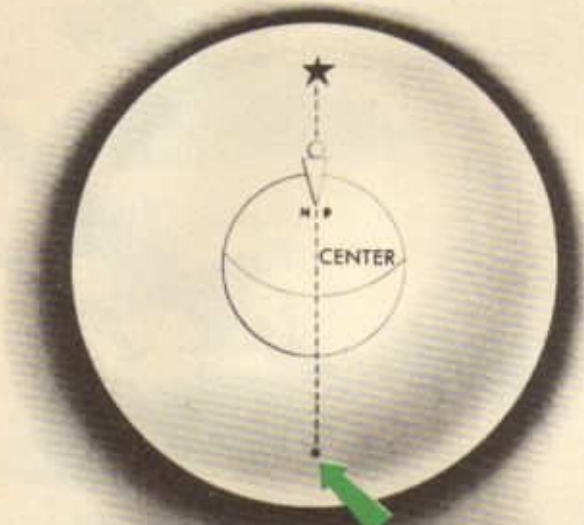

NADIR IS ON OPPOSITE SIDE OF SPHERE

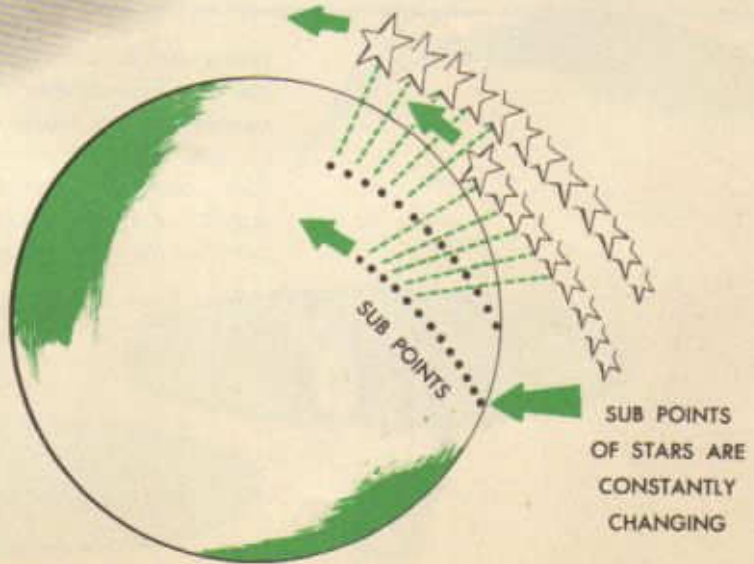
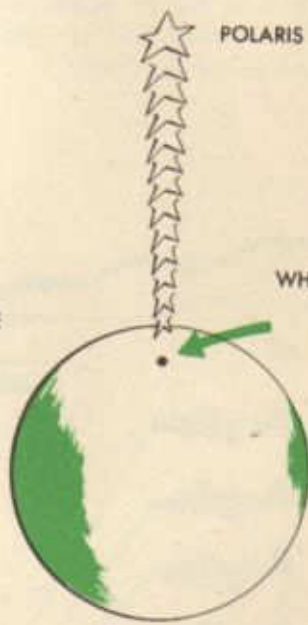

Actually the earth does not provide wanderers with a sign post at the north pole; therefore it is necessary to know exactly when Polaris is directly overhead. Since the star is such an infinite distance away from the earth the position of the pole cannot be established by simply looking up. Measurements must always be made in relation to some known point. In this case the known point is the observer's horizon.

The simplest concept of horizon is the line which appears to an observer at sea to mark the intersection of earth and sky. This horizon, called the *visible horizon*, varies with elevation; therefore it is not of much practical value as a reference point to a navigator several thousand feet above the earth.

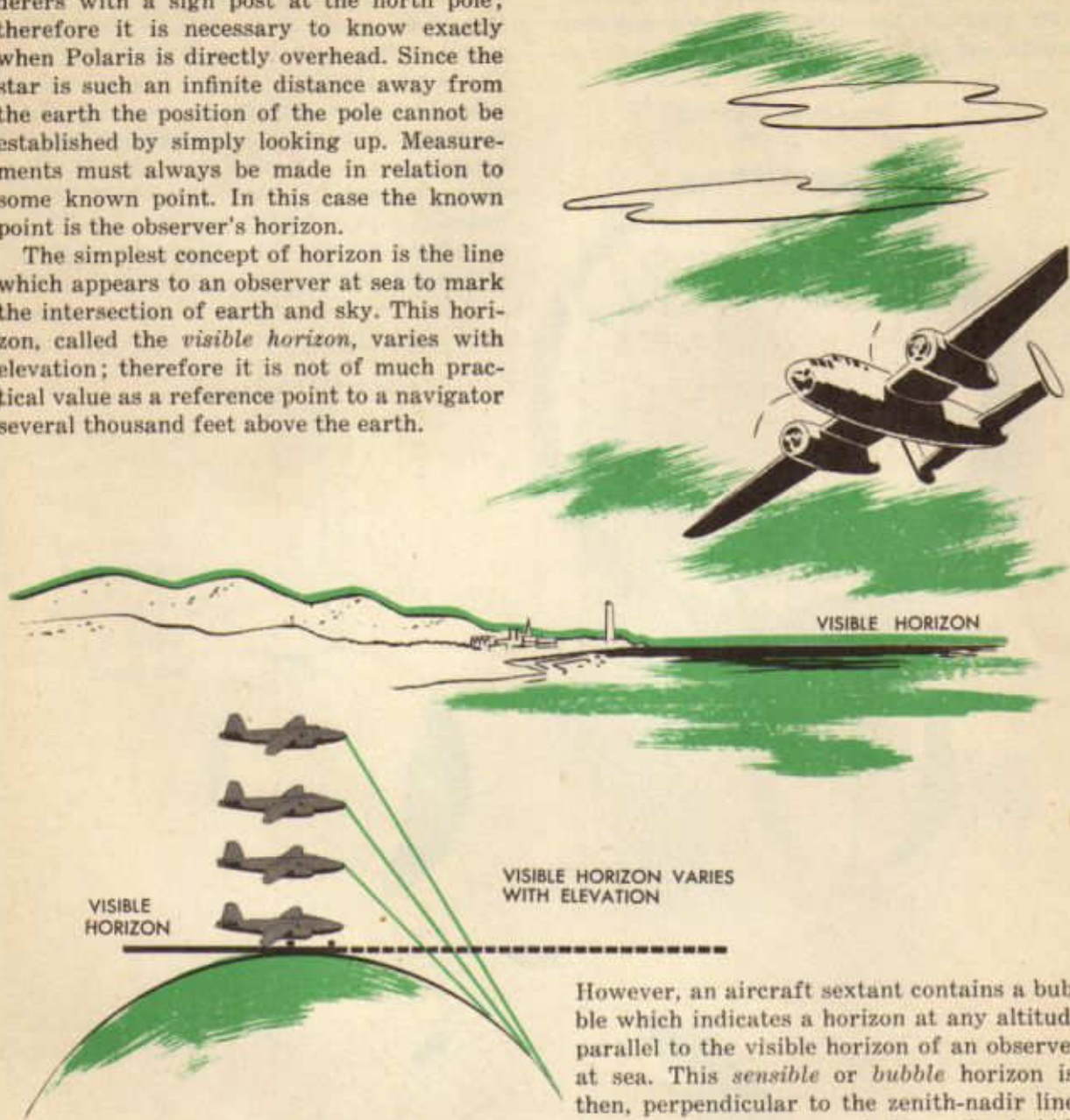

However, an aircraft sextant contains a bubble which indicates a horizon at any altitude parallel to the visible horizon of an observer at sea. This *sensible* or *bubble horizon* is, then, perpendicular to the zenith-nadir line. Angles can be measured from the bubble horizon as a reference point (0°) to zenith

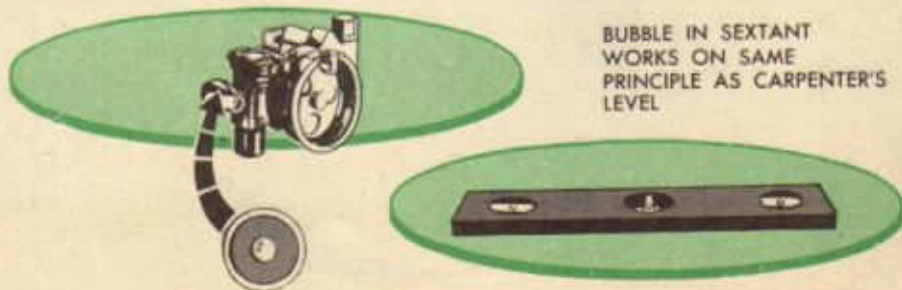

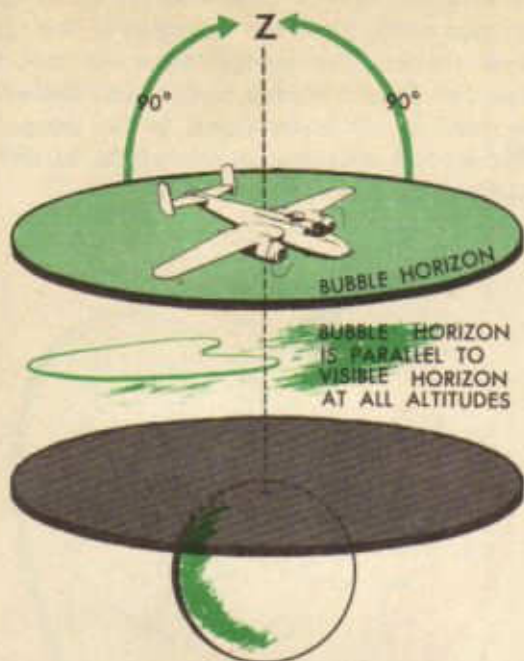

(90°). This angle at the observer's eye between the horizon and the line of sight to a body is the height or *altitude* of the body. Thus, a star on the horizon has an altitude of 0°. The altitude of a star half way to the zenith position is 45°. When a star has an altitude of 90° it is directly overhead.

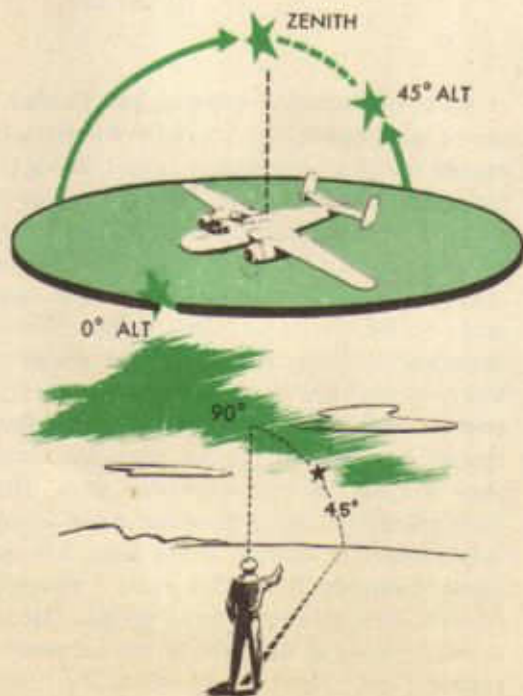

It will be remembered that the angular distance between the equator and the north pole measured at the *center* of the earth is 90°, and this 90° arc encloses 5,400 nautical miles on the *surface* of the earth. Therefore, one minute of arc measured at the center of the earth represents one nautical mile of linear measurement on the surface.

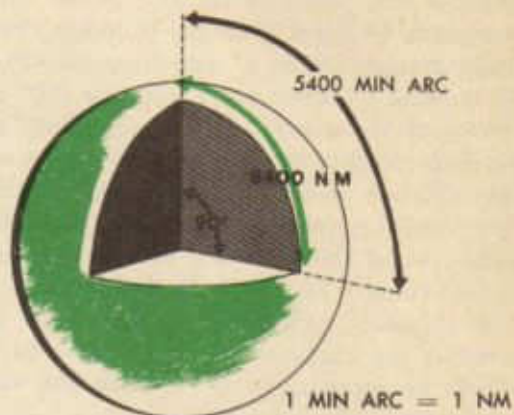

Since stars are such an infinite distance from the earth it can be assumed for navigation purposes that altitudes of stars are measured at the center of the earth instead of the observer's eye. In other words, a horizon, called celestial horizon, through the center of the earth parallel to the bubble horizon is assumed to be the reference point from which altitude is measured. The few thousand miles which separate the observer from this position is of little consequence compared to the millions and millions of miles to the celestial sphere. Since altitude, then, is angular measurement at the center of the earth each minute of arc may be referred to in terms of one nautical mile of linear measurement on the surface of the earth.

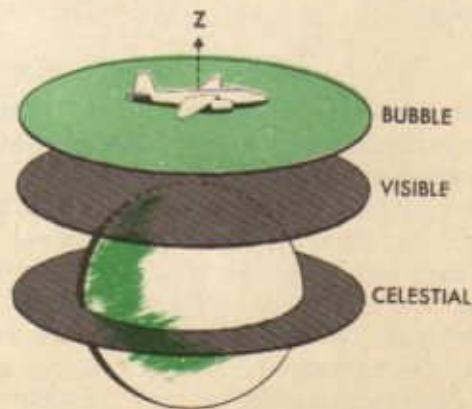

The practical application of this fact can be most easily understood in connection with Polaris. It must be remembered at the moment that this star is directly over the north pole; therefore its altitude to an observer at the pole, its subpoint, is 90° . As the observer moves one mile away from the subpoint the altitude of the star diminishes one minute and becomes $85^\circ 59'$. When the observer is 60 miles from the subpoint the altitude changes $60'$ or 1° and becomes 89° . But, in moving 60 miles from the pole (90° north latitude) the observer has reached 89° north latitude. Is this the only position from which the altitude of Polaris is 89° ? Obviously, if the observer walked along the 89° N latitude line around the pole, the altitude of Polaris would remain 89° , because the distance from the subpoint remains 60 miles. This circle around the subpoint of the star is called a circle of equal altitude because the star is observed at the same altitude from any point on the circle.

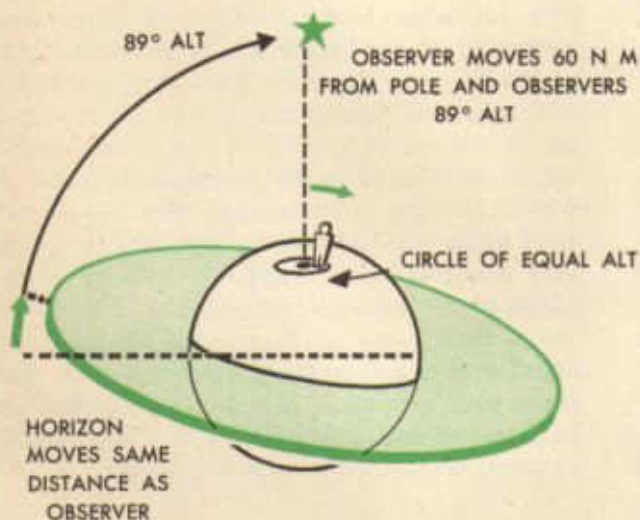

When the altitude of Polaris is 45° where on the earth is the circle of equal altitude? Obviously it is exactly half way between the subpoint of Polaris, the north pole, and the equator. In other words, the observer is somewhere on the 45° north latitude line. He may be on this latitude in North America or Asia and still observe Polaris to be half way between the horizon and zenith. Suppose another observer ascertained the altitude of

Polaris to be 46° . Is this observer closer to or farther away from the subpoint of the star? How much? The second observer sees the star one degree higher in the sky; therefore he must be 60 miles closer to the subpoint. The second observer is, therefore, at 46° N latitude.

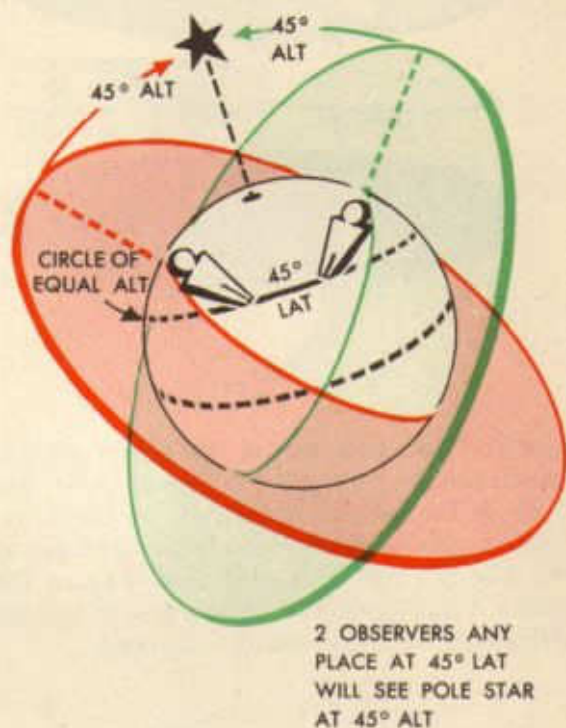

As the equator is approached Polaris sinks lower and lower until finally its altitude becomes 0° at 0° latitude. Casual thought may indicate that it would be impossible to see Polaris at low latitudes due to the curvature of the earth. Actually, with one important exception, rays of light from any heavenly body appear to be parallel. A line between an observer at any point on the earth and a body is parallel to a line between the body and an observer at any other point. Railroad tracks are known to be parallel; however, they appear to run together at a distance. This phenomenon is present when observing most celestial bodies since they are such a great distance from the earth; therefore, a ray of light from Polaris to the equator is parallel to a ray of light to its subpoint. This concept that light from the stars travels in

parallel rays is very fundamental to navigation. It is obvious, however, that an observer in south latitude cannot see Polaris because the earth is in the path of light rays to the observer's eye.



Polaris has been used as an example to illustrate several fundamental concepts of navigation, since it occupies a unique position in the celestial sphere. If the polar axis of the earth were extended to the celestial sphere, it would mark the positions of the north and south celestial poles, and Polaris is a visual

indication of the approximate position of the north pole on the celestial sphere. This special star was used to explain certain facts which are applicable to any star.



POLARIS IS ONLY 1° FROM POLE

The application of these facts to other stars is slightly more difficult due to their motion; however, no trouble should be encountered as long as it is remembered that altitude is assumed to be measured at the center of the earth using the celestial horizon, which is at right angles to the observer's zenith-nadir line, as a reference plane. Zenith and nadir move on the celestial sphere as the observer moves on the earth, zenith remaining directly above and nadir exactly 180° from it. Thus, the horizon shifts as the observer changes position, always acting as a dividing marker between the visible half-sphere and the invisible one.

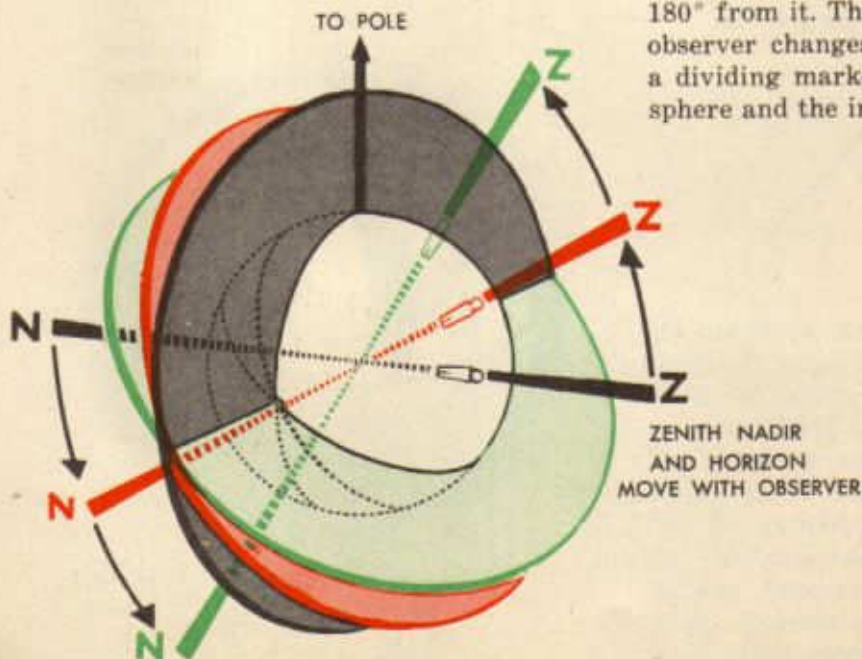

The relationship of altitude (H_o) assumed to be measured at the center of the earth and distance on the surface of the earth remains unchanged because the earth is regarded as a perfect sphere at the center of the larger celestial sphere. This relationship, that one minute of arc at the center of the earth measures one nautical mile on the surface, is still dependent upon a knowledge of the location of the star's subpoint. Like Polaris, the subpoint of any body can be as much as 5,400 miles away from the observer. Obviously, it is impossible to plot such a line on a chart, and there is really no need for doing so as long as the altitude (H_c) and the direction (azimuth) of the subpoint can be calculated from a known position. Then, the observer can be located on a line of position (circle of equal altitude) by the relationship between H_o and H_c . The mechanical calculation for this circle of equal altitude has already been discussed. The circle of equal altitude is normally so large that no appreciable error is introduced by drawing the line of position tangent to it.

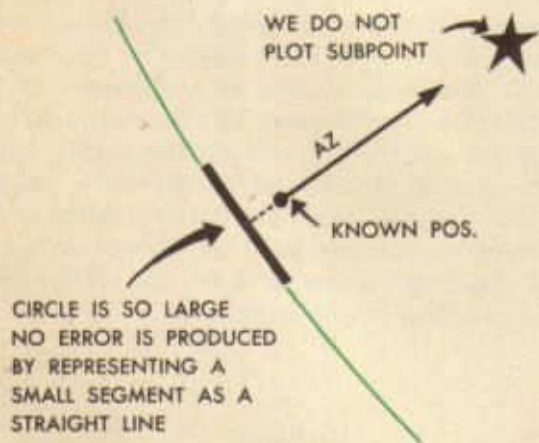

On the earth it is possible to locate an object by a system of coordinates (latitude and longitude). Since for practical purposes stars remain in their relative positions, it is possible to devise some means whereby any particular star can be located. What would be more logical than an extension of the earth's coordinates to the celestial sphere? If this is done, the poles of the earth can be extended an infinite distance through space until they hit the celestial sphere where they

become the respective celestial poles. Likewise, the earth's equator can be expanded to become the celestial equator. Long ago the

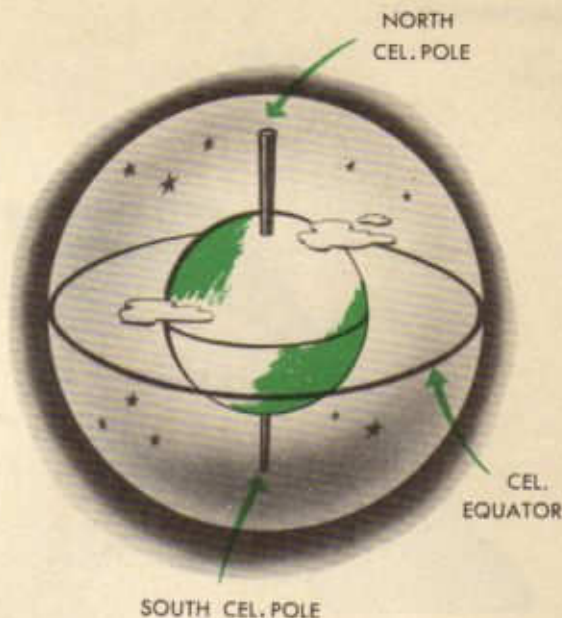

Greeks selected a reference point in the sky to serve as the celestial prime meridian. They called this point, which was a group of stars at that time, the first point of Aries (Υ). It is the point at which the sun crosses the equator in the spring on its journey to the northern hemisphere.

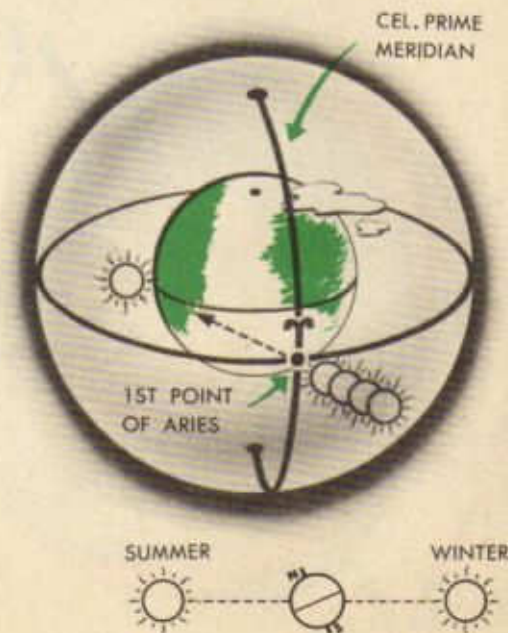

With these two reference points, equator and Aries, stars can be accurately located in terms of declination and hour angle which in terrestrial terms mean the same as latitude and longitude, respectively. A star 10° north of the celestial equator is said to have a declination of 10° N. This star, then, passes directly over the head of an observer whose latitude is 10° N.

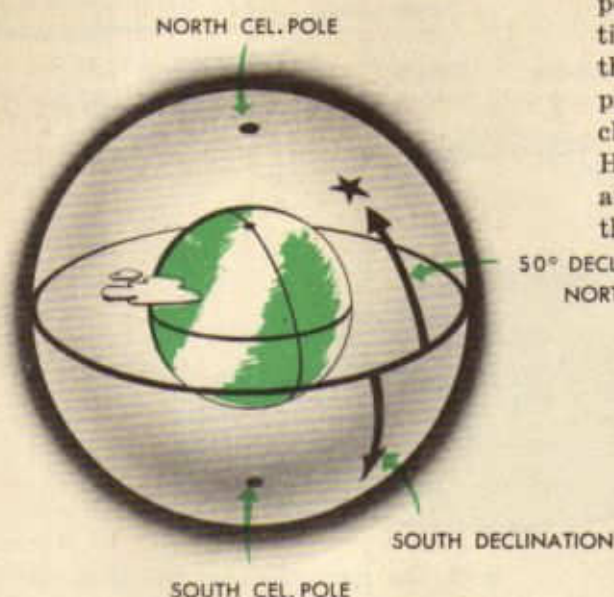

If the movement of the universe could be stopped for an instant as the first point of Aries is directly over the prime meridian, a star directly over 90° west longitude would make an angle of 90° at the north celestial pole with the Aries meridian or hour circle.



Thus, the hour circle of the star becomes 90° , and the star is said to have a sidereal hour angle (SHA) of 90° . SHA is always measured westward through 360° from the reference point (Υ) to the hour circle passing through the star. Thus, SHA becomes celestial longitude. Start the universe moving again, and since stars maintain their relative positions in the sky the SHA of the particular star will remain 90° regardless of the position of Aries. However, it will not continue to hover above 90° west longitude; therefore the angle which it makes with the prime or Greenwich meridian is constantly changing. This angle is called Greenwich Hour Angle, or GHA, since it indicates the angle between the Greenwich meridian and the meridian of the subpoint.



A star maintains its celestial latitude and longitude (declination and SHA) in relation to Aries just as Chicago remains at a constant latitude and longitude in relation to the prime meridian. Since the star is constantly moving around the earth, it is impossible to ascertain its relationship to the terrestrial prime meridian at any particular instant unless the exact time of the observation is known. For instance, it is known that altitude becomes smaller as the observer moves away from the subpoint of a body. What happens when the body moves while the observer remains in one position? If the star has a declination equal to the observer's latitude it will rise due east. As it peeps over the horizon its altitude is 0° , and its subpoint is 5,400

miles away ($90^\circ \times 60$). The stationary observer ascertains that the altitude increases 15° each hour as the star approaches his zenith. At the end of six hours the star is directly overhead at an altitude of 90° ; therefore, its subpoint and the observer's position are identical. Thus, the subpoint of the star traveled 5,400 miles on the earth in six hours at the rate of 900 knots. As the subpoint continues westward at the same rate, the altitude becomes smaller until the star passes from the stationary observer's view.

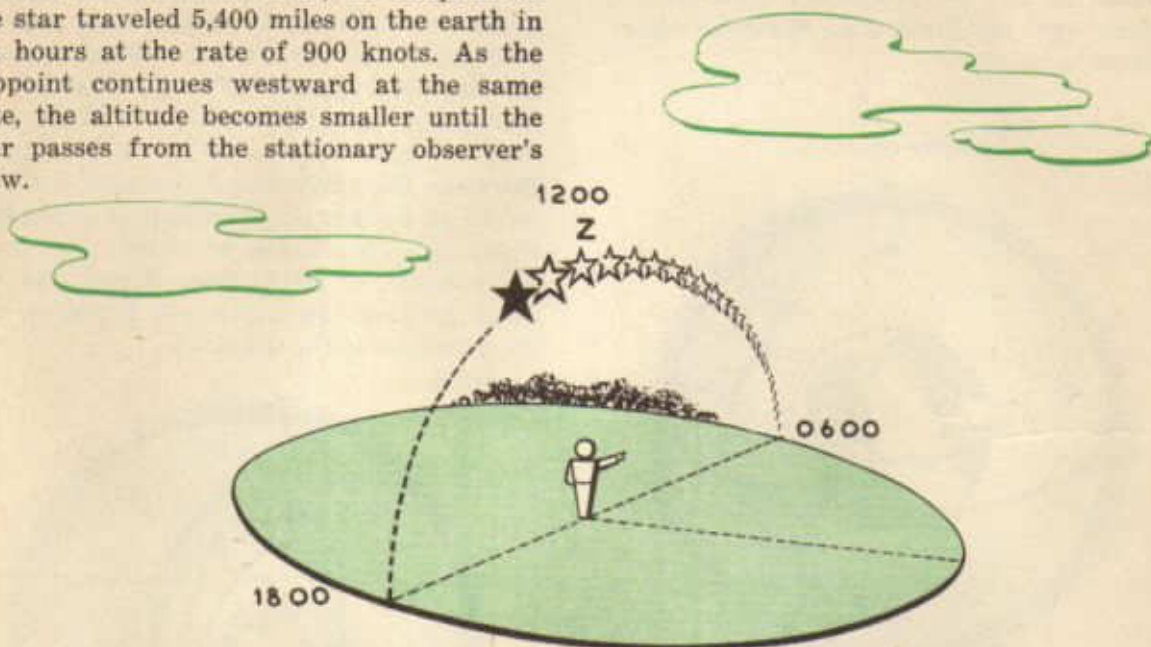

Both the movement of the observer and the movement of the body affect the altitude of the body. The observer determines his position by previously discussed navigation techniques. The observer can determine the body's position and the position of its subpoint at Greenwich civil time with an air almanac. The observer determines the LOP by the solution of the astronomical triangle. The vertices (corners) of this triangle are (1) the elevated pole (2) the body (3) the observer's Zenith.

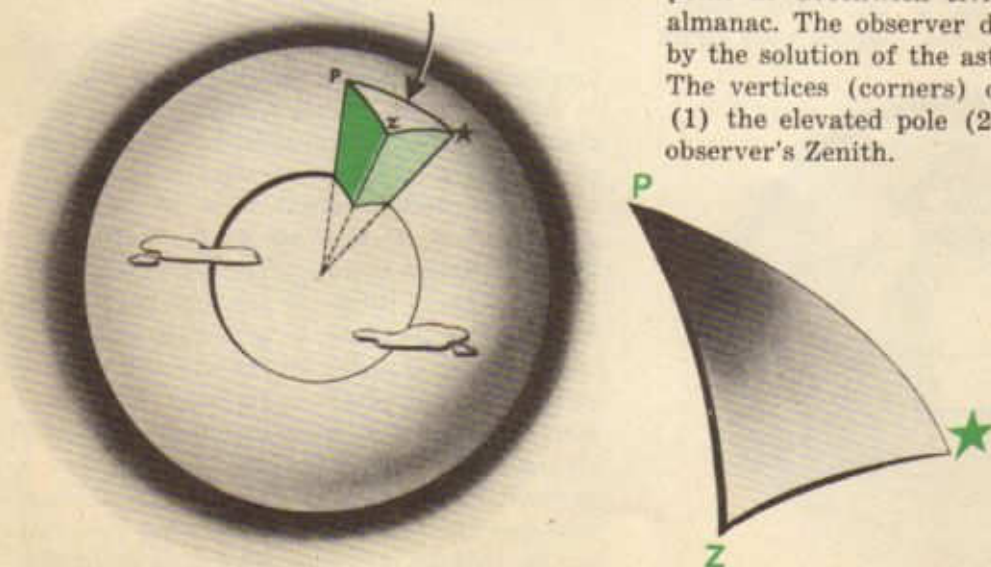

The observer locates the body with its celestial coordinates, declination and Greenwich Hour Angle. Declination of the body equals the latitude of its subpoint. The distance of the body from the elevated pole is co-declination ($90^\circ - \text{dec.}$). This equals the distance of the subpoint from the terrestrial pole, which is called co-lat. ($90^\circ - \text{lat.}$). Greenwich Hour Angle of the body ($\text{GHA} \mp$

point, on the earth. The distance of the observer's zenith from the elevated pole is co-lat. ($90^\circ - \text{lat.}$). The longitude remains unchanged, as it was originally measured from

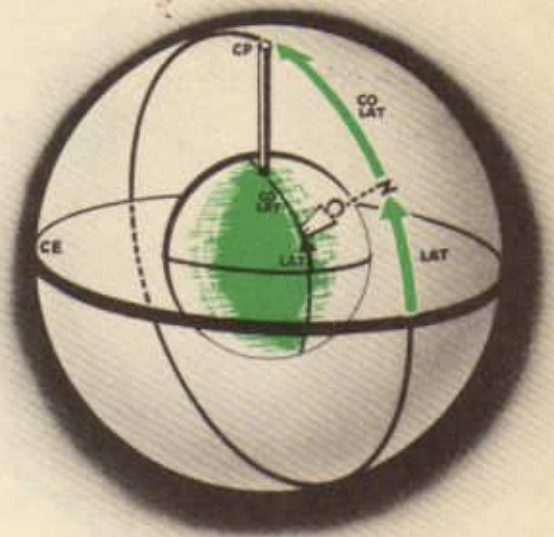
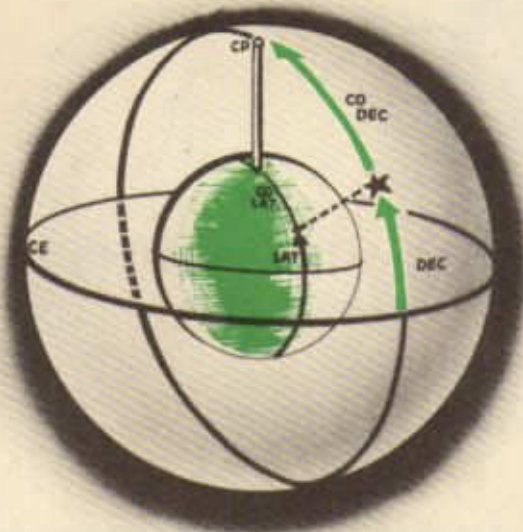

$\text{SHA} \star = \text{GHA} \star$) is the distance of the body from the Greenwich meridian. This will be the longitude of the subpoint. Now the star is located on the celestial sphere and its sub-

Greenwich. The angular distance between the zenith and the body is called Zenith Distance. This angular distance is the complement of the altitude of the body observed from the position used in the solution. The direction of the body from the observer's zenith is called the azimuth.

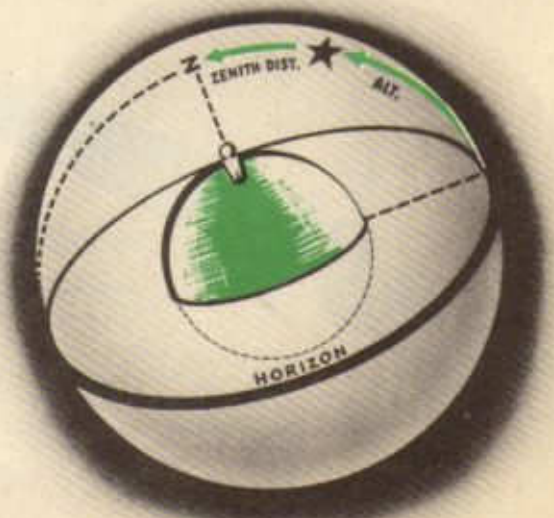
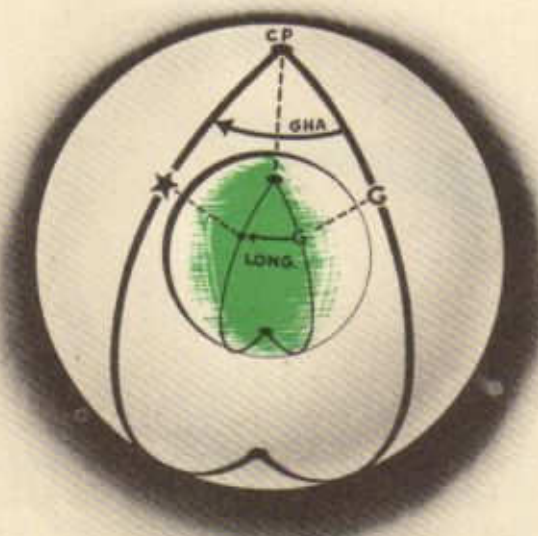

The astronomical triangle can be solved for the azimuth and altitude (H_c) of a body from a definite position at particular time. Suppose the body was observed with a sex-

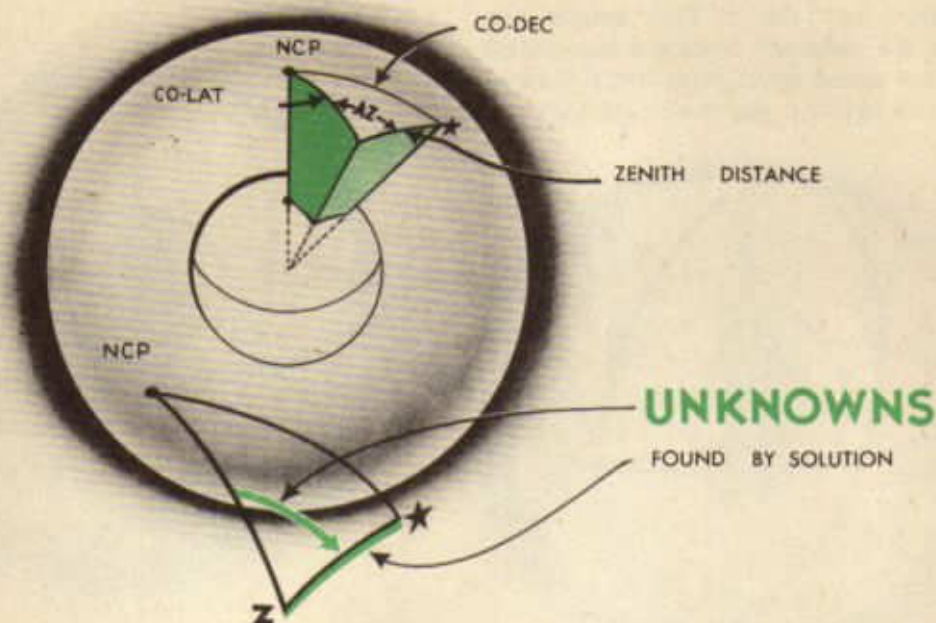

tant from the definite position at the particular time. Disregarding observation errors, the observed altitude (H_o) would be the same as the calculated altitude (H_c). In determining a line of position, the relationship between H_o and H_c is used to determine how many miles separate the two circles of equal altitude. If H_o is greater than H_c by, for instance, 15' of arc, the observer is on a circle

of equal altitude 15 miles nearer the subpoint measured along the azimuth from the position used to calculate H_c . When H_o is less than H_c the observer is on a circle of equal altitude farther away from the subpoint.

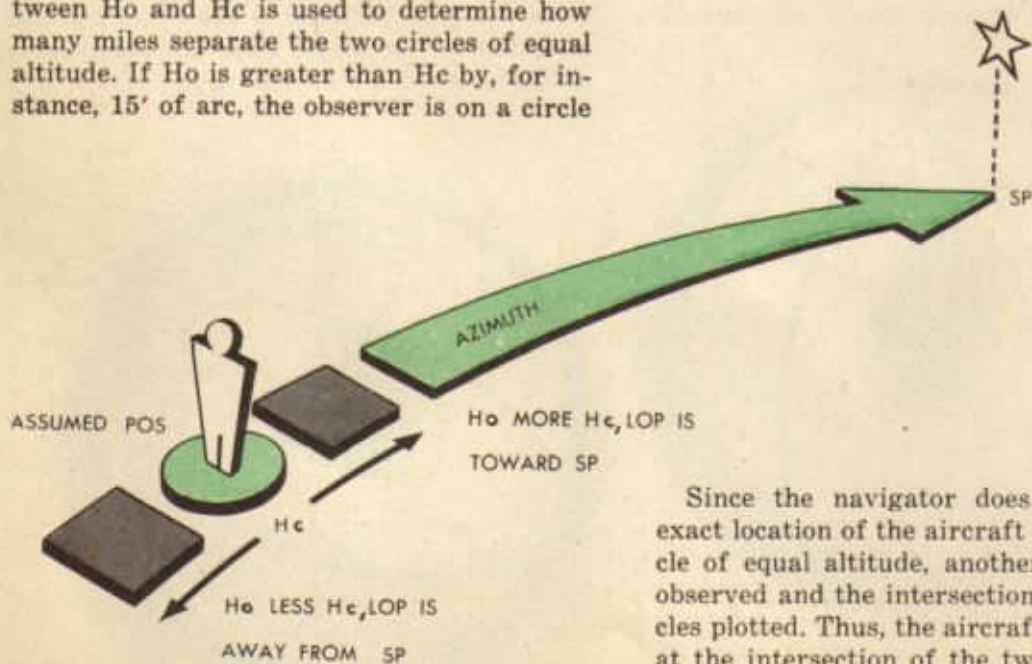

Since the navigator does not know the exact location of the aircraft on this vast circle of equal altitude, another body must be observed and the intersection of the two circles plotted. Thus, the aircraft will be located at the intersection of the two lines of position at the same instant.

Chronometers and Time

One of the earliest records of time and its measurement is recorded in the first chapter of Genesis wherein it states that God separated the light from the darkness and named the light Day and the darkness Night. For quite some centuries, people were satisfied with this story because it made no conflict with their belief that the earth was flat. As evidence was advanced, indicating that the earth was round, early scientists suggested that night and day were in reality caused by the rotation of the earth on its own axis.

According to history, those who took issue with the beliefs and traditions of the church were forever damned in the life to come and therefore deserving of persecution in *this* life. In spite of the early persecutions, hypotheses led to new discoveries and new discoveries to new knowledge. Present day conception of time is based upon definite laws of motion among heavenly bodies.

The laws we are most concerned with in a study of time are:

1. The earth rotates on its own axis from west to east, thus causing heavenly bodies to appear to rotate around the earth from east to west.

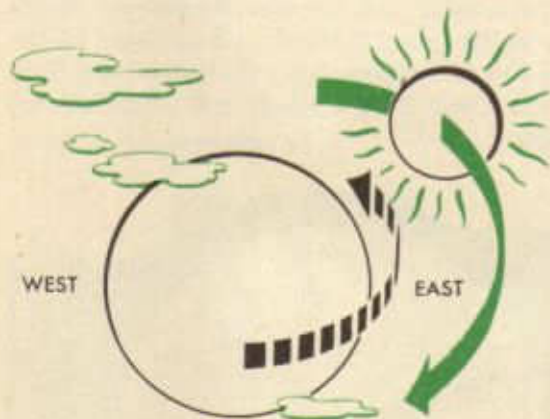

2. The earth revolves around the sun, making the path of an ellipse. The earth's rate is not constant, but is proportional to its distance from the sun. This distance varies during the different seasons of the year.

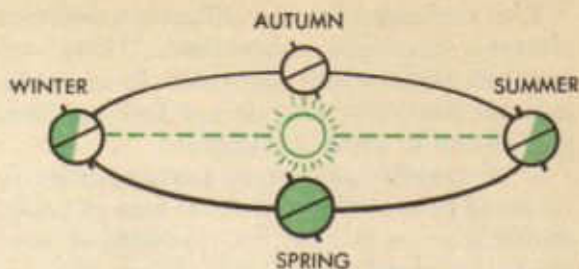

Without going into the motions of heavenly bodies in detail it may be stated that time is reckoned from the stars (sidereal time) and from the sun (solar time). The period of time it takes the earth to make one complete revolution about the sun is called a year. This year is divided into $365.24+$ rotations or days. Each day is divided into 24 hours, each hour into 60 minutes and each minute into 60 seconds.

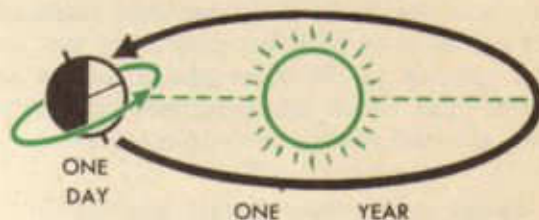

Because the earth makes one revolution around the sun during a year, it loses one rotation in reference to the sun. This can be visualized if it is realized that during one rotation, the earth has advanced itself along its orbit. The net result is that it arrives at the same place in reference to the sun approximately 3 minutes 56 seconds before the actual rotation is completed. This effect does not occur in relation to the stars because they lie entirely outside the earth's orbit. Consequently, the earth makes $366.24+$ rotations as far as the stars are concerned.

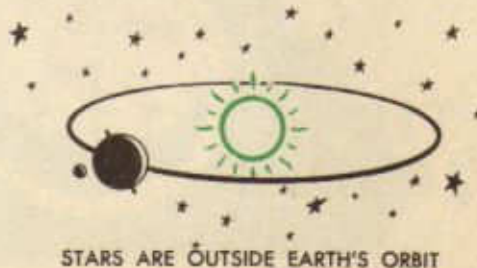

This accounts for the difference between sidereal time and solar time. There are watches made which are rated to maintain sidereal time, but they do not find practical application in aerial navigation.

If the earth's axis were perpendicular to its plane of rotation, and if the rate of travel on its orbit were even, the problem of time would be greatly simplified. When the sun passed the meridian of the observer, it would be exactly 1200 noon and time could be taken directly from the position of the sun in the sky. We find that such is not the case, however, and a new time had to be devised. If the sun's apparent motion through the sky is reduced to an average rate, we have the basis of "civil" (or mean) time which is the time recorded on ordinary watches and clocks. This is accomplished by assuming that there is an "imaginary" sun either ahead or behind the real or apparent sun, depending upon the season of the year. There are four instances during the year that the imaginary sun and real sun are in the same places, but in between these times, the imaginary sun varies from the real sun by up to 16 minutes.

WE USE AN IMAGINARY (MEAN) SUN THAT MOVES AT A CONSTANT RATE TO DETERMINE CIVIL TIME

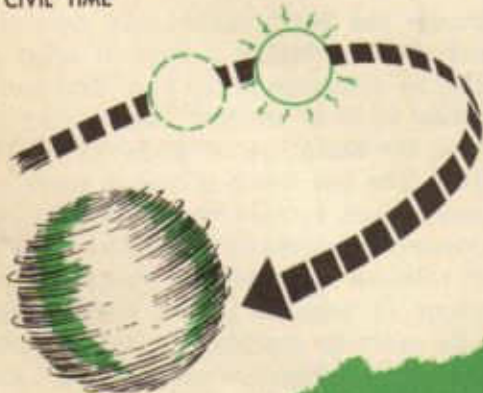

TIME ZONES

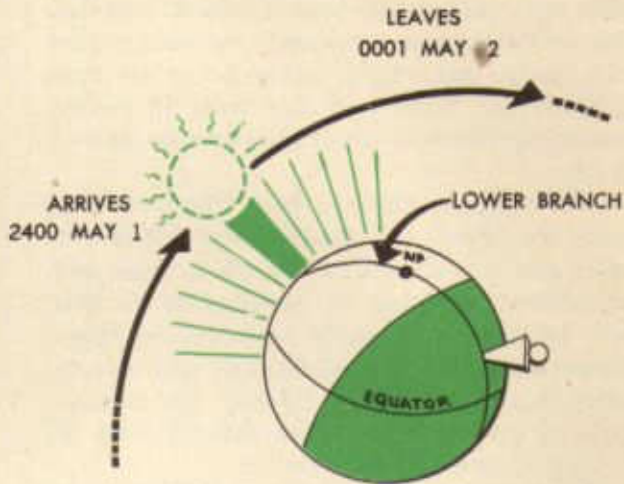

lishes the relationship between time and longitude, but brings up another problem. If time is based upon longitude, two people in the same vicinity, yet at different longitudes, would have to carry different times on their watches.

To answer this, it was decided to divide the earth into 24 bands, all persons in the same band or zone using the same time. This is the Time Zone System and is illustrated below.

INTERNATIONAL DATE LINE

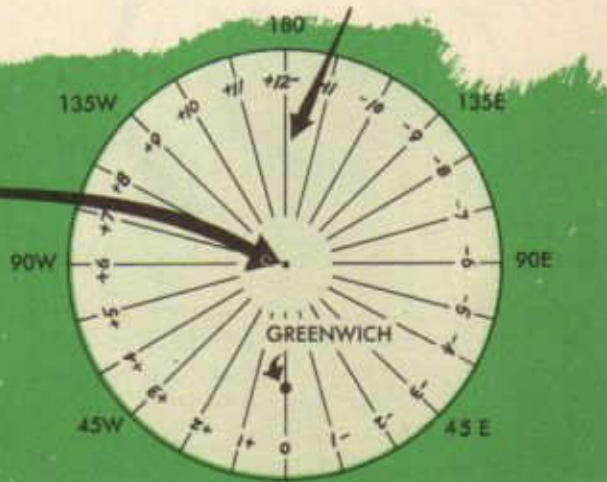

Notice that Greenwich England is in the center of the "0" time zone. To avoid mistakes in time and date, most navigators carry GCT on their watches exclusively.

Each zone has 15° of longitude or, in terms of time, one hour of time. The 180th meridian is known as the International Date Line. As the mean sun passes the date line, it is 0000 at *Greenwich, England*, which is the beginning of a new date. As the sun advances 15°, it becomes one hour later at Greenwich, England. However, for those in time zone No. 1, that instant represents 0000 zone time or the beginning of *their* new day. It

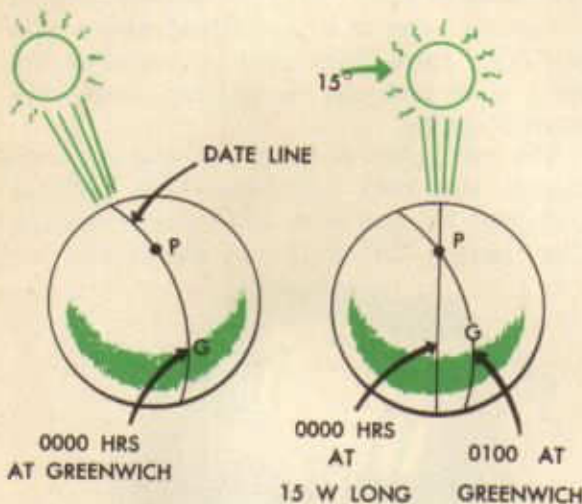

can be seen that in west longitude it is always earlier in time. Likewise, Greenwich always has a later time than zones in west longitude and consequently those time zones are named "plus." For instance, Standard Zone Time in the Fifth Time Zone plus five hours is equal

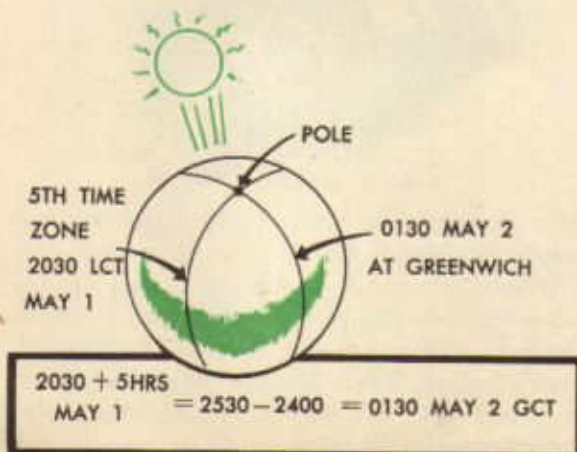

to Greenwich Civil Time. If the addition produces a figure over 2400, subtract 2400 and add a calendar day.

The division between time zones is often changed to fit geographical divisions. In the United States there are four zones (Eastern, Central, Mountain, and Pacific), with the divisions between each being state lines. In addition, special changes are made at various times which vary the time in respective zones by an extra hour. Central War Time is one hour earlier than Central Standard Time.

To further explain the relationship between zone time and Greenwich Civil Time, the following example is furnished. A navigator is carrying Central War Time (CWT) on his hack watch. The Central Time Zone is the Sixth Zone, but War Time is one hour earlier. Therefore, if his watch reads 1330, the Greenwich time = 1330 + five hours, or 1830. If his watch reads 2200, for instance, and his date is October 13th, Greenwich time is 2200 + five hours, or 2700; subtracting

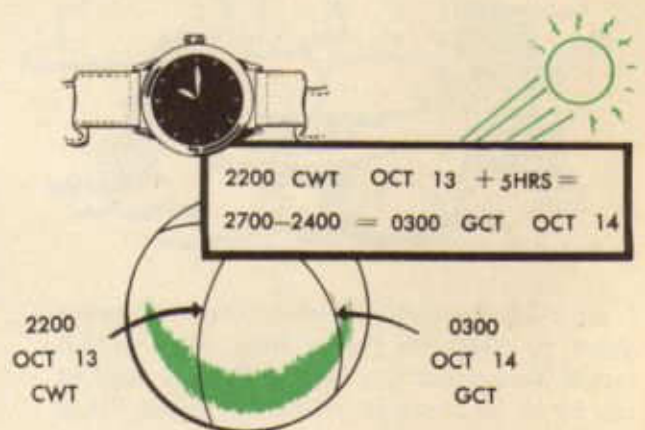

2400 and adding one calendar date makes the Greenwich Civil Time and Date 0300 October 14th. Regardless of where the navigator travels, if he carries CWT on his watch, he makes the conversion to Greenwich Civil Time in exactly the same manner.

A point often difficult to comprehend is that if a watch is set to GCT, regardless of what part of the world the navigator is in or what local time and date exists, the watch still reads GCT.



The first crude portable watches date from about the year 1500. There were three principal mechanical difficulties to overcome in producing the modern time piece:

1. Errors in rate due to the changing tension on the main spring as it unwound.
2. Need of a suitable escapement to replace the pendulum.
3. Erratic rates due to temperature and humidity changes.

The manner in which these difficulties were overcome is an interesting story and one in which the British Government played an important part.



In 1714, the British Government offered a prize of \$100,000 for a time piece which would determine the longitude of a ship at sea to an accuracy of within 30 miles. Since 30 miles represents an error of at least two minutes in time, it will be seen that a dollar Ingersol watch with the daily radio ticks now available would have won the prize. The \$100,000 was claimed in 1773 by Harrison following a voyage from England to Jamaica. The voyage lasted 147 days, during which the chronometer lost one minute 55 seconds.

In general, the modern watch and chronometer were developed between the years 1500 and 1800 and a great deal of money was expended in the development. The modern watch is one of the mechanical marvels of

the age. A moderately priced master watch is expected to count the 86,400 seconds of the day without missing more than one or two of them. This represents an accuracy of 1 to 40,000.

The navigator should know the difference between a chronometer, master watch and hack watch.

A chronometer beats each half second; that is, 120 times a minute. It has a helical coil hair spring and is driven by a constant tongue drum and chain. It is the most delicate navigation instrument used and must be treated as such. Chronometers are rarely carried in aircraft. They are usually kept in a briefing room or at operations with a rate and error card. They must be wound at the same time each day to prevent their rate from changing.

The navigator is mostly concerned with master and hack watches. These watches beat each $\frac{1}{3}$ second or 300 times a minute. They have a flat spiral hair spring and are



MASTER WATCH AND CASE



HACK WATCH

gear driven. The master and hack watches should be wound at the same time each day. The master watch should be rated in the same position the navigator carries it in the aircraft. This usually is the navigator's watch pocket. There is a carrying case which is issued with the watch, erroneously called non-magnetic. Most aircraft do not have a

receptacle suitable for the case, and care must be taken that the case is not vibrated to the floor. Care also must be taken to prevent these watches from becoming wet.

Rates that may be expected:

Chronometers — Less than 1 sec/24 hours.

Master watches — Less than 5 sec/24 hours.

Hack watches — Less than 30 sec/24 hours.

If a watch stops, do not bang it: the pivots of the balance wheels are about the thickness of a human hair. It is practically impossible to get replacement parts in an advanced combat theater . . . so act in accordance.

Remember this: "Only damn fools and jewelers open watches!"

The accepted procedure for rating watches is as practical as it is simple. Accurate time is ordinarily available daily through the widespread use of radio time signals. Each day at the same time, the reading of the watch is compared with the correct time. The difference between the correct time and the reading on the watch is known as *error*, and is expressed in minutes and seconds to the nearest half second. *Daily rate* is the error which developed in the 24-hour period just elapsed. *Average rate* is the total error divided by the number of days elapsed since the watch was set correctly.

RATING OF WATCH						
Greenwich Date	GCT	Reading of Watch	ERROR F	S	Daily RATE	
					Gain	Loss
Oct. 12	17-00-00	17-00-00	00-00			
Oct. 13	17-00-00	17-00-12	00-12		12	
Oct. 14	17-00-00	17-00-22	00-22		10	
Oct. 15	17-00-00	17-00-36	00-36		14	
Oct. 16	17-00-00	17-00-45	00-45		9	



Accurate radio time signals are broadcast all over the world several times daily. For instance, Washington (NAA) broadcasts the time signals on frequency 113 kc., from 5 minutes before each hour, except at 0200, 0400, 1400, and 1600, GCT. Other stations broadcast the time tick at various times and on various frequencies.

If such a system is employed, it is unnecessary that a navigation watch read exact GCT. If the error is known, together with a record of what rate to expect, exact GCT may be determined at any time by simple arithmetic. Watches whose rates are excessive should be adjusted by competent personnel, and re-rated.

The United States System is the signal code most widely used. The signal begins 5 minutes before the hour to be marked and consists of a dot for each second. The dot for the 29th second is omitted. The identification for the exact minute to follow is made between the 50th and 60th second. After the 50th (or 51st, 52nd, or 53rd, depending upon which minute is to follow) second, a tick is missed. The number of ticks which follow

identify the minute to follow. For instance, if two ticks are heard, the minute is the second minute to follow before the new hour. If no ticks are sounded during this period, the minute of the even hour follows. The minute begins at the beginning of the signal which follows the lull. While this description may sound complicated, actually the system is extremely simple and once heard is easily remembered.

RADIO TIME SIGNAL

STARTS ON THIS MINUTE	SEC.	28	29	30-50	51	52	53	54	55	56	57	58	59	60	THIS MINUTE COMING UP
	55	--	0	---	0	-	-	-	0	0	0	0	-	56	
	56	--	0	---	-	0	-	-	0	0	0	0	-	57	
	57	--	0	---	-	-	0	-	0	0	0	0	-	58	
	58	--	0	---	-	-	-	0	-	0	0	0	-	59	
	59	--	0	---	-	-	-	-	0	0	0	0	-	60	

SILENCE: 0

CHRONOMETER RATING

Greenwich Date	GCT	Reading of Watch	ERROR		Daily Rate	
			F	S	Gain	Loss
Jan. 12	18-00-00	Watch Set				
Jan. 13	18-00-00	17-59-50				
Jan. 14	18-00-00	17-59-41				
Jan. 15	18-00-00	17-59-30				
Jan. 16	18-00-00	17-59-26				
Jan. 17	18-00-00	17-59-16				

Greenwich Date	GCT	Reading of Watch	ERROR		Daily Rate	
			F	S	Gain	Loss
Jan. 12	18-00-00	Watch Set				
Jan. 13	17-59-00	17-59-02				
Jan. 14	18-00-00	18-00-06				
Jan. 15	17-59-29	17-59-40				
Jan. 16	18-00-00	18-00-13				
Jan. 17	18-00-00	18-00-18				

In addition, there is a time service furnished by the Bureau of Standards which sends out every second of time throughout the day.

This service, known as the "Standard Frequency Broadcast," is transmitted on 5 megacycles and is a continuous signal. It is used by those desiring the exact time and also by musicians who can check musical tones by the tone of the signal. The tone is transmitted continuously except for the first minute of each five-minute period, which is silent. Obviously, the time must be known to the closest five minutes to use this signal, but no great difficulty is presented here.

The majority of radio time signals are transmitted automatically, being controlled by the standard clock of an astronomical observatory. These radio time signals are within .25 of one second and therefore may be considered accurate enough for aircraft astro-navigation.

It is not considered good practice to use commercial radio station announcements to rate watches. It may be a certain "Bulova" time, but if the navigator is careful in rating his own watch, he'll find commercial stations off up to 30 seconds. Occasionally an announcer will name the wrong hour, but of course he apologizes after the next phonograph record is played. Don't depend upon others; rate your watch yourself.

USING THE LINE OF POSITION IN MORE DIFFICULT PROBLEMS

Meridian Altitudes

The observer's latitude can be found easily when the astronomical triangle is represented by a straight line. This occurs when the subpoint of body is on the observer's meridian or exactly 180° away on the opposite side of the pole. The observer's meridian in celestial terms is known as the *upper branch*. The meridian on the opposite side of the sphere 180° away, then, becomes the *lower branch*.

Four arrangements of the three vertices of the astronomical triangle are possible.

When the declination is *contrary* in name to the observer's latitude, zenith is between the elevated pole and the body. As the observer views the body, the angle from the horizon is the altitude. But the body is on the opposite side of the equator from the observer by an amount equal to its declination; therefore the equator can be located by imagining it to be between the star and the observer's zenith. The latitude of the observer can now be found by subtracting the angle between the visible horizon and the equator (Altitude + Dec) from 90° . In other words, latitude equals $90^\circ - (\text{Altitude} + \text{Dec})$.

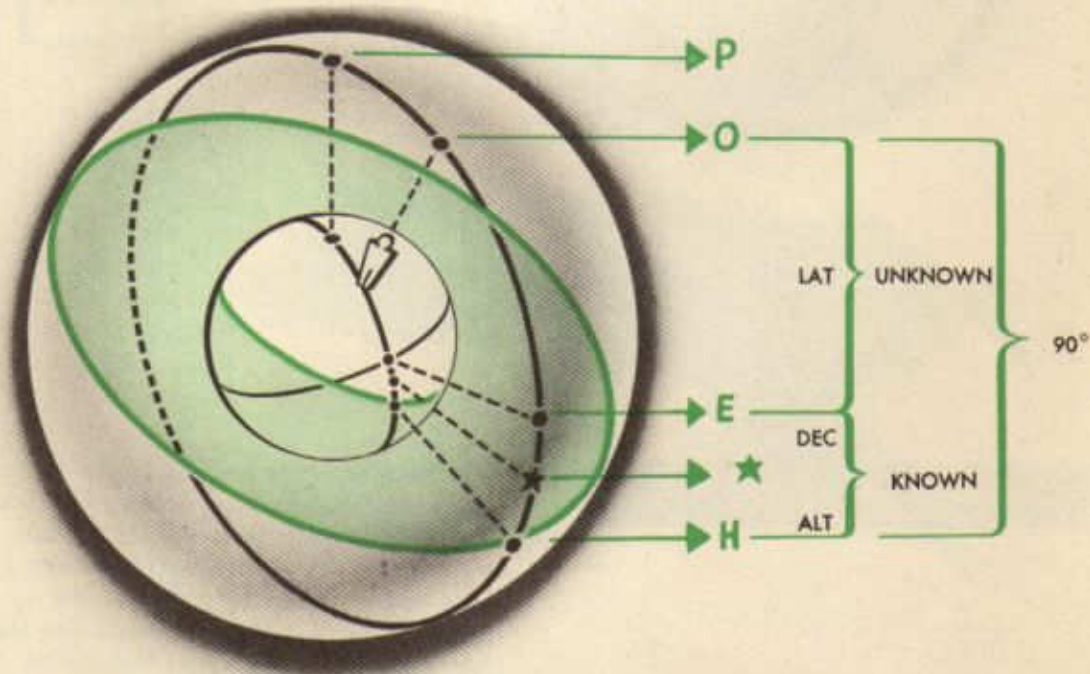

$$90^\circ - \text{KNOWN} = \text{UNKNOWN}$$

$$90^\circ - (\text{ALT} + \text{DEC}) = \text{LAT}$$

Another arrangement of the vertices of the astronomical triangle occurs when declination is the *same* name but *less* than the latitude of the observer. The three points are on the upper branch with the body lowest on the horizon, zenith next, and then the pole.

Altitude is the angle from the horizon to the body. But the equator is lower than the star; therefore latitude, which is the angular distance from the equator to zenith, can be found by subtracting (altitude — Dec) from 90° ; or latitude equals $90^\circ - (\text{Alt} - \text{Dec})$.

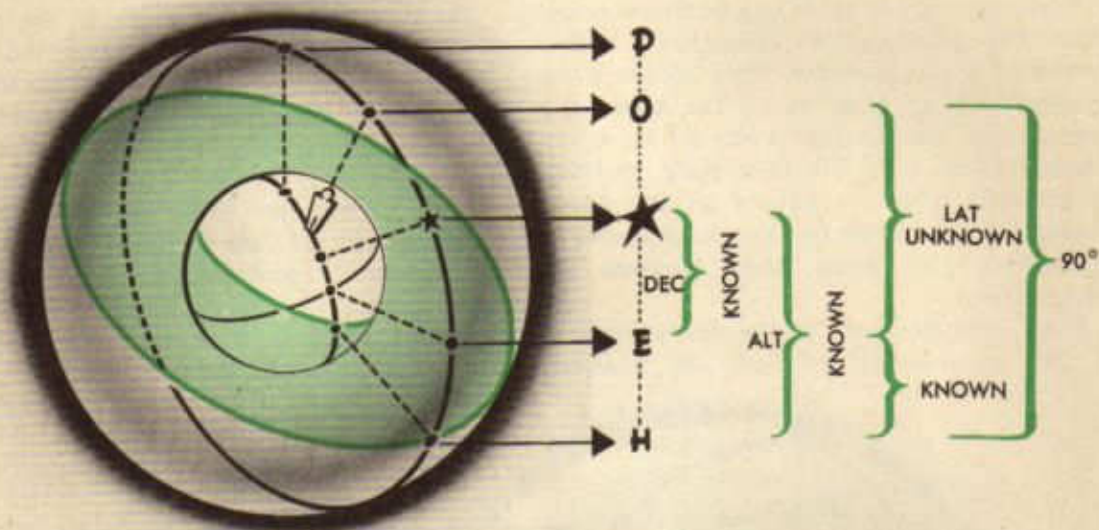

$$LAT = 90^\circ - (ALT - DEC)$$

In both of these conditions the sum of latitude, declination, and altitude equals 90° . This relationship is true at all times; however, under some conditions latitude can be most easily found by using co-dec or polar distance ($90^\circ - \text{Dec}$) to locate the elevated pole instead of applying declination to the star's position to locate the equator.

Take, for instance, the case when the body is on the observer's *lower branch* (LHA 180°). In this instance the pole is between zenith and the body, but latitude equals the altitude of the elevated pole. Altitude of the body is measured from the horizon to the body. The latitude of the observer, then, becomes equivalent to the distance from the

horizon to the star (altitude) plus the distance from the star to the elevated pole ($90^\circ - \text{Dec}$). Thus, latitude equals altitude + co-dec.

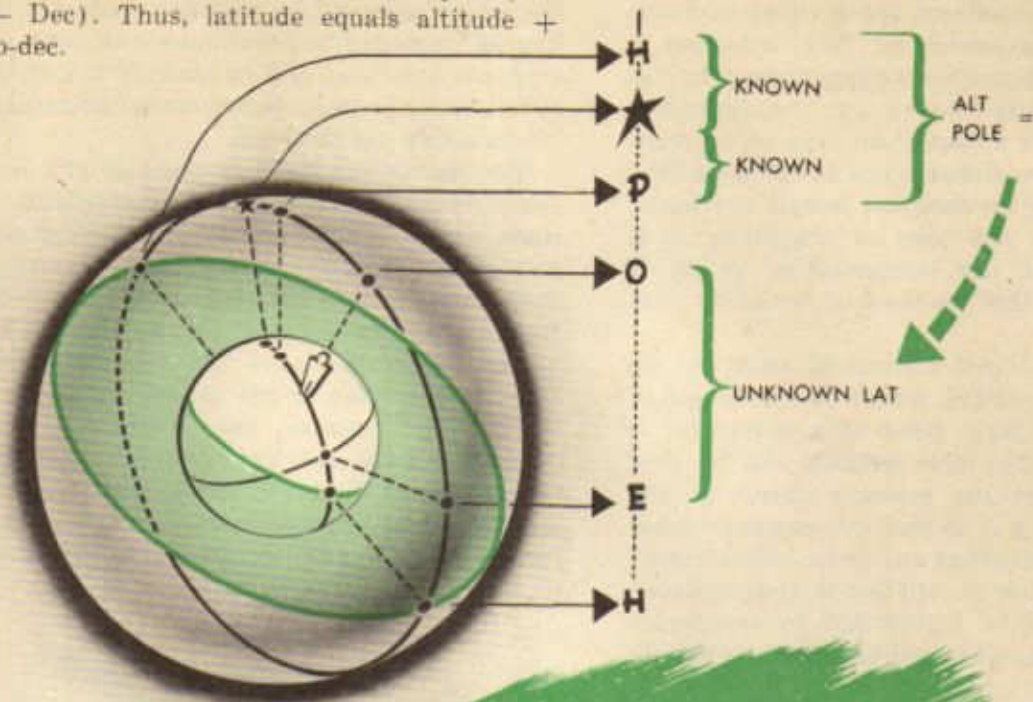

$$\text{LAT} = \text{ALT} + \text{Co DEC}$$

The fourth and last possible arrangement of these three points in a straight line occurs when the body is between the pole and zenith. The declination is the *same* name but *greater* than the observer's latitude. Just as in the preceding example, the latitude of the observer equals the altitude of the elevated

pole. Since in this case the body is between the pole and zenith it follows that the pole is between the body and the horizon. The angular distance from the body to the pole is co-dec; therefore the altitude of the body minus co-dec is the altitude of the elevated pole. Latitude, then, is equal to altitude — co-dec

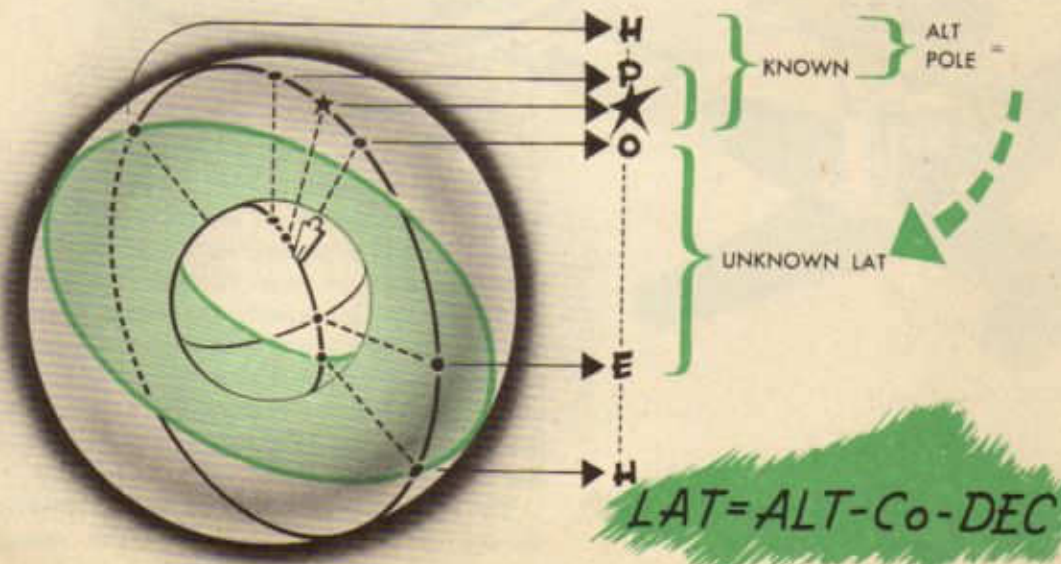

$$\text{LAT} = \text{ALT} - \text{Co-DEC}$$

Compass Correction

Celestial procedures can be used to determine compass deviation. This technique is especially advantageous since ground swinging is frequently inconvenient and sometimes inaccurate for a particular type of aircraft. Previously mentioned steps in compensating and swinging the compass remain the same; however, for the sake of simplicity it is assumed that the compensating swing is complete and that the residual deviation must be found.

Perhaps the best method of swinging the compass by celestial means is by the use of the astro-compass. When this instrument is set up correctly, true heading can be read directly. Since the primary object of any compass swing is to find the magnetic heading of the aircraft at any given instant, variation must then be applied to true heading. Deviation can be determined by comparing compass headings to corresponding magnetic headings.

The astro-compass is an instrument designed primarily to determine the true heading of an aircraft. In addition, however, it can be employed to determine true bearing, compass deviation, and to identify a star. In either case the same fundamental principles of operation are followed.

The instrument itself is made up of a leveling device, movable drums, a declination scale, and a sighting device. A mounting device accompanies the astro-compass in order that it can be installed in a turret parallel to the longitudinal axis of the airplane. The actual manipulation of the instrument is fool-proof as long as the directions are followed. For instance, the portion of the mounting base marked "AFT" must be placed toward the tail of the airplane. A slot and keyway arrangement assures the proper insertion of the astro-compass into the base.

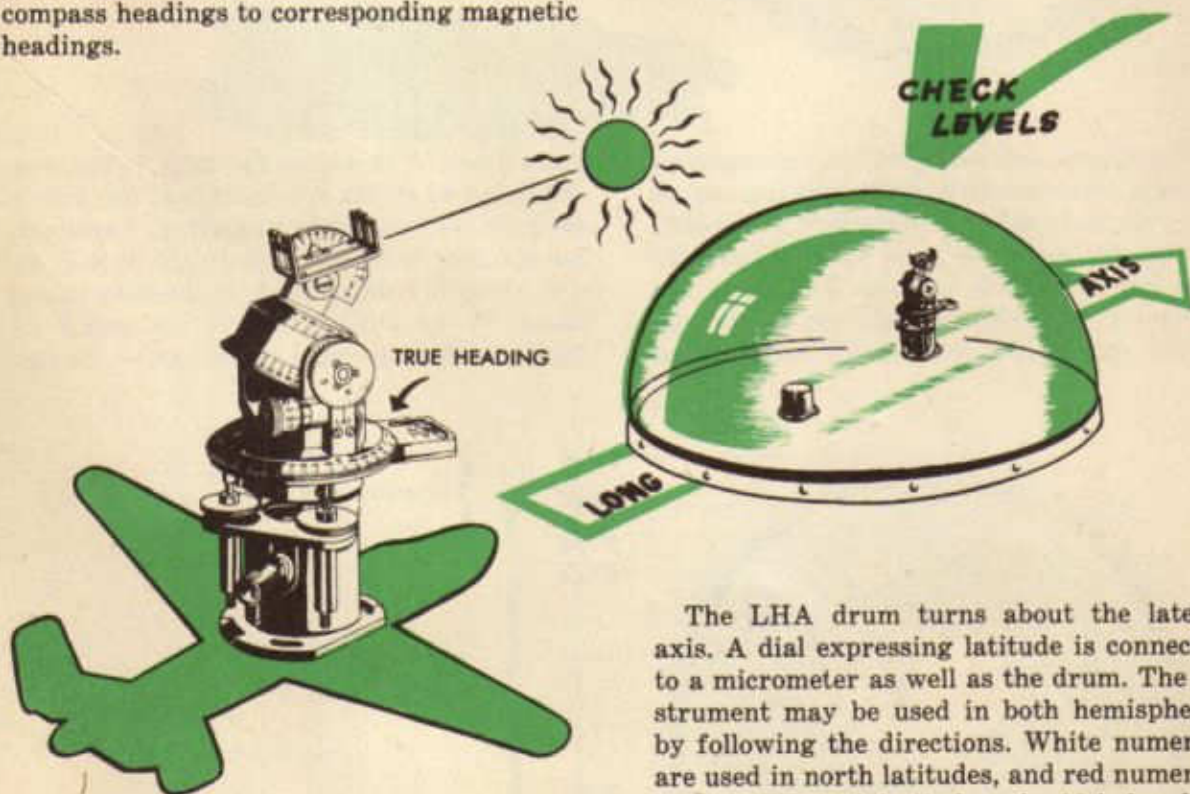

The LHA drum turns about the lateral axis. A dial expressing latitude is connected to a micrometer as well as the drum. The instrument may be used in both hemispheres by following the directions. White numerals are used in north latitudes, and red numerals are used in south latitudes; the 90 is in white only. The knob for setting LHA is opposite the latitude dial. This drum provides a horizon for the instrument.

The declination scale bracket is mounted on top of the astro compass. The scale is

graduated 64° to 0° to 64° with the letters N and S at opposite ends marked in white and red. Attention is paid only to the white markings in north latitude, to red markings in south latitudes.

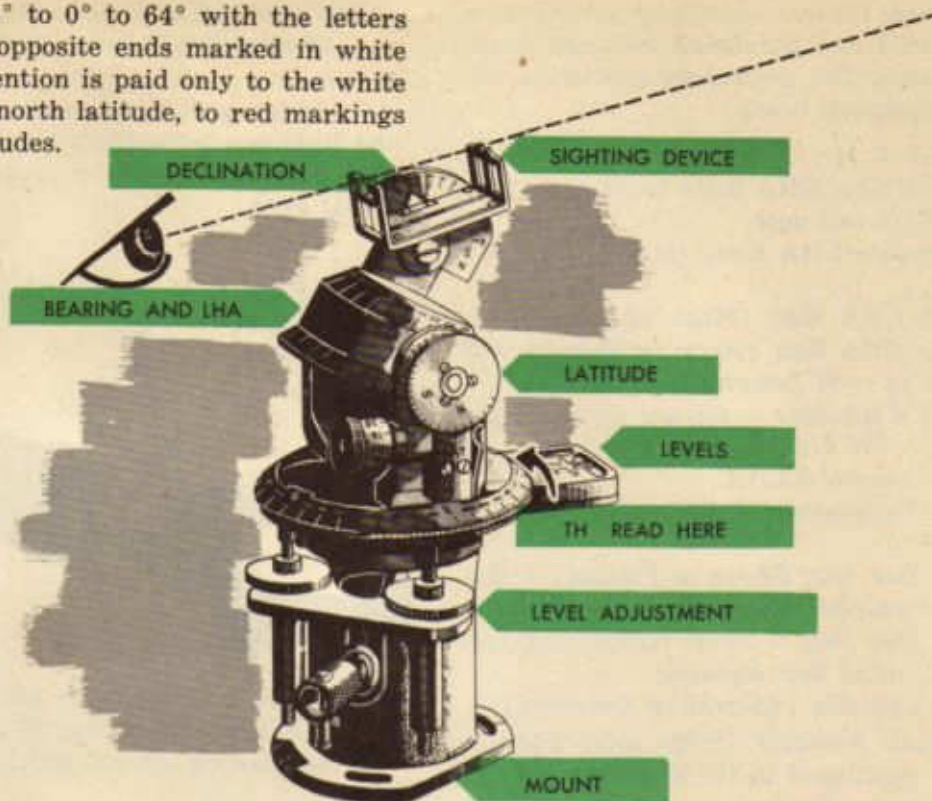

The sighting device is attached to the declination scale bracket. The fore sight is constructed with a shadow bar in the lower area and luminized sight lines at the top. The rear sight is equipped with a lens whose focus is infinity with the fore sight when an object is sighted beyond the fore sight. The rear sight has a translucent screen with two parallel lines to correspond with the fore sight bar. When all settings are accurately made, the

star will appear at the intersection of the white lines in the fore sight. This will seldom occur due to slight errors; therefore a star is considered properly positioned when it appears vertically above or below the line intersection. When observing the sun (and sometimes the moon) the shadow cast by the fore sight bar falls within the parallel lines on the bottom and rear of the sighting device.

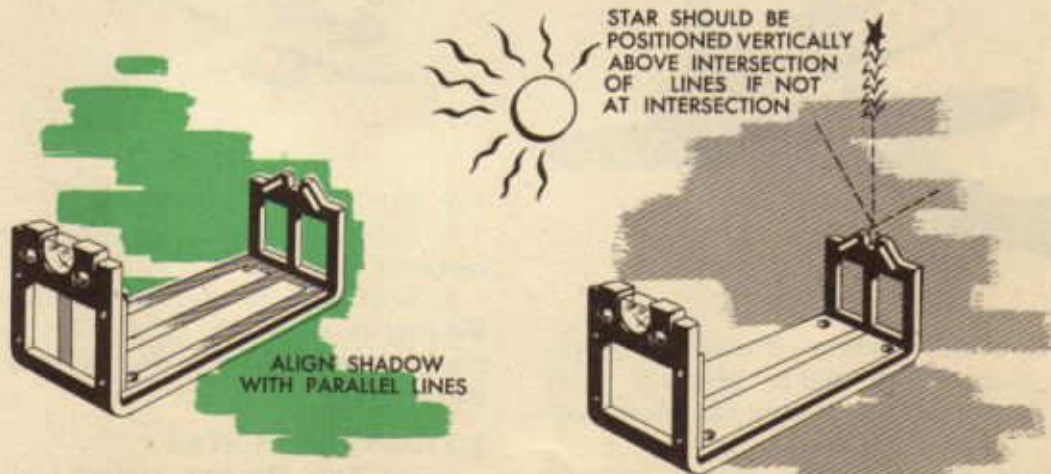

In all uses the astro-compass must be carefully leveled and paralleled with the longitudinal axis. The remaining procedure follows as indicated below:

TO FIND T H:

1. Determine GHA Body from Air Almanac for GCT and date.
2. Compute LHA Body (always use LHA West).
 - (a) LHA Sun (Moon or Planet) = GHA Sun (Moon or Planet) + E or -W Longitude.
 - (b) LHA Star = GHA Υ + SHA Star - W Longitude.
3. Set computed LHA.
4. Set Declination of Body from Air Almanac.
 - (a) Dec. Sun (Moon or Planets) = Extracted against GCT and date.
 - (b) Dec. Star = From inside back cover of Air Almanac.
5. Set Latitude (Assumed or Observed).
6. Rotate Azimuth Circle until body is properly positioned in the sights.
 - (a) Sun—Shadow appears on shadow screen of Sight.

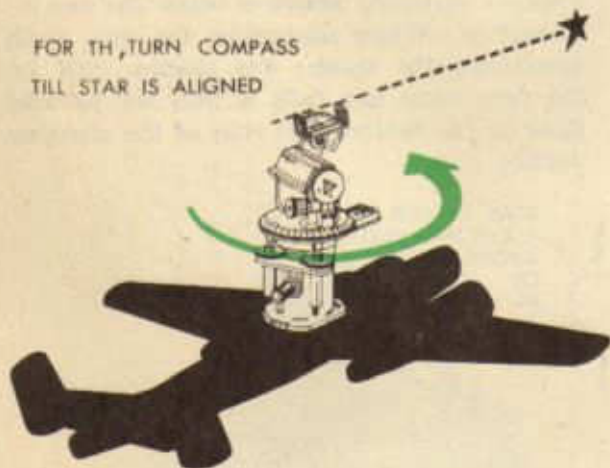

- (b) Moon, Planets, Stars — Body appears in sights properly positioned. Frequently the Moon will cast a shadow.

7. Read True Heading against lubber's line.

TO STEER A TRUE HEADING:

1. Obtain True Heading by the above means.
2. Instruct pilot to turn the airplane until the Body can be properly sighted.
3. Maintain heading by compass or directional gyro.

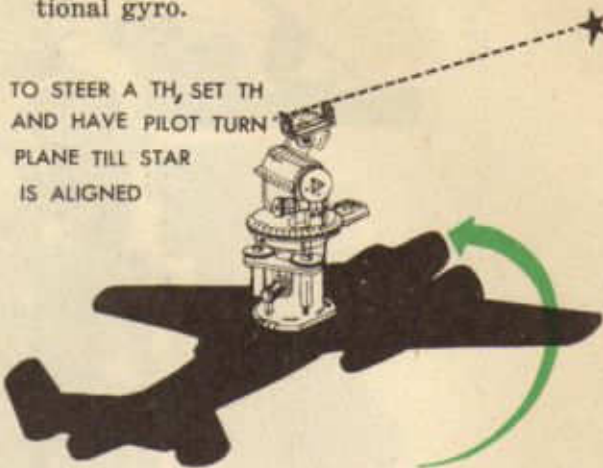

4. Check heading with astro-compass at intervals of not more than 15 minutes, altering the heading steered on the gyro if necessary.

TO OBTAIN THE RELATIVE BEARING AT A DISTANT OBJECT:

1. Set 360° (N) against True Heading lubber's line.

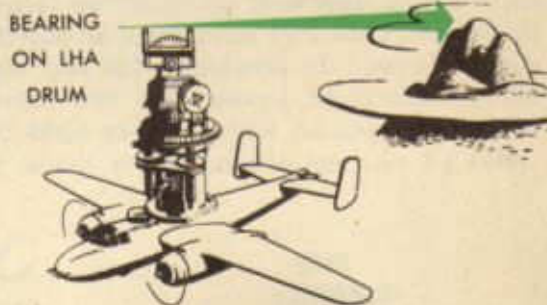

2. Set Latitude scale at 90°.
3. Rotate LHA scale until object appears correctly in sights.
4. Read relative bearing against True Bearing datum mark. (Note: True Bearing results when True Heading is set opposite lubber line.)

TO IDENTIFY A STAR:

1. Set True Heading against lubber line.
2. Set Latitude.

3. Rotate LHA scale and adjust sights until star appears in sights at intersection of lines.

4. Read Declination and LHA of star on respective scales.

5. Extract GHA Υ against GCT and Date from Air Almanac.

6. Determine SHA star by: $SHA = LHA \star - E$ or $+W$ Long. $- GHA \Upsilon$.

7. Extract name of Star from inside back cover of Air Almanac against SHA and Declination.

TO DETERMINE COMPASS DEVIATION:

1. Determine True Heading of aircraft as usual.

2. Apply variation to obtain Magnetic Heading.

3. Read Compass Heading at time of determining True Heading.

4. Compass Heading minus Magnetic Heading is deviation.

In addition to the astro-compass, the drift-meter and shadow pin may be used to determine compass deviation. Unlike the astro-compass, which provides true heading directly, these instruments provide, directly or indirectly, a relative bearing of the celestial body from the aircraft.

The azimuth of a celestial body is used as a basis for this method. True azimuth, meas-

ured clockwise from true north to the line connecting the airplane's position to the sub-point of the body, is computed by H. O. 218 or any other solution of the astronomical triangle. Magnetic azimuth is obtained when local variation is applied to true azimuth. Magnetic azimuth minus relative bearing gives the magnetic heading.

One method of finding the relative bearing is by use of the shadow pin. The shadow pin consists of an azimuth ring printed on paper and fastened to a wood or metal platform. In the exact center of the azimuth ring is a thin metal rod which projects vertically about three inches above the surface of the ring. As the name implies, the shadow pin is activated by the light of the sun which shows the shadow of the pin on the azimuth ring, allowing the relative bearing of the sun to be read. To do this, the pin must be very carefully placed. It is mounted in the turret with the 0° - 180° line parallel to the longitudinal axis, with 180° to the front of the ship. Thus, if the sun is directly behind the airplane, the shadow falls on 180° , the relative bearing of the sun. In an AT-7, it is necessary to rotate the turret in order to get a shadow on some headings. When this is done, it is necessary to add or subtract 180° to the Shadow Pin reading in order to get the relative bearing.

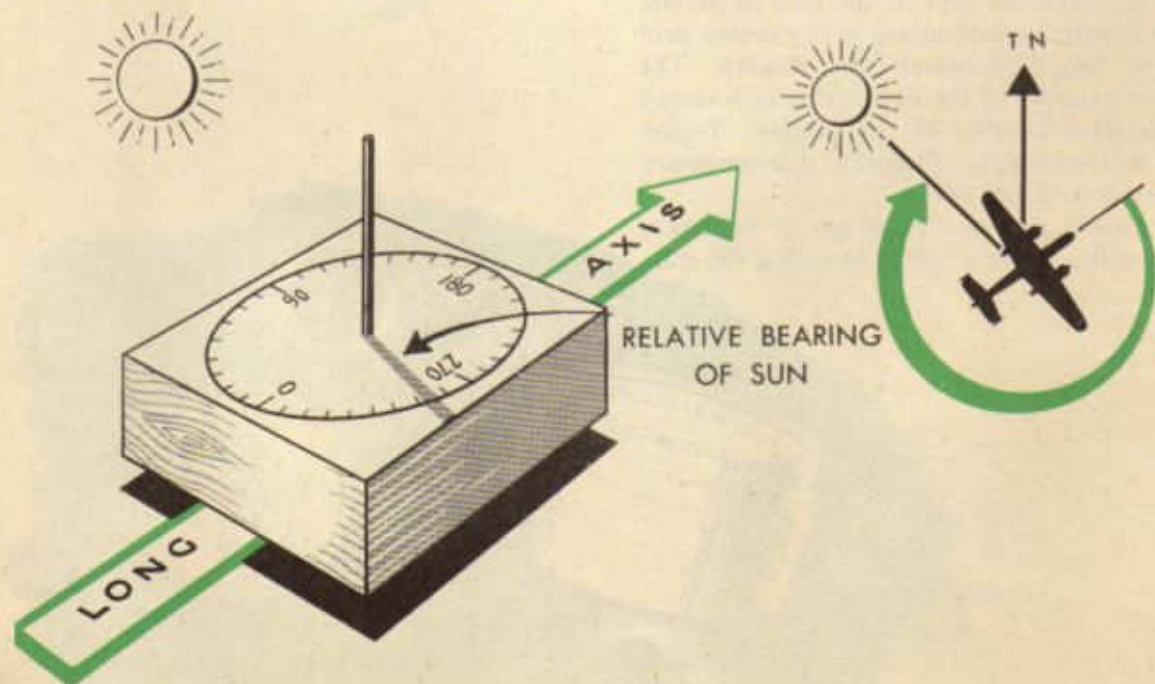

The other method of obtaining relative bearing is by use of the driftmeter. When the driftmeter is used, the relative bearing of the shadow of the airplane itself on the ground is observed. The shadow is always on the opposite side of the aircraft from the sun. When taking a relative bearing, rotate

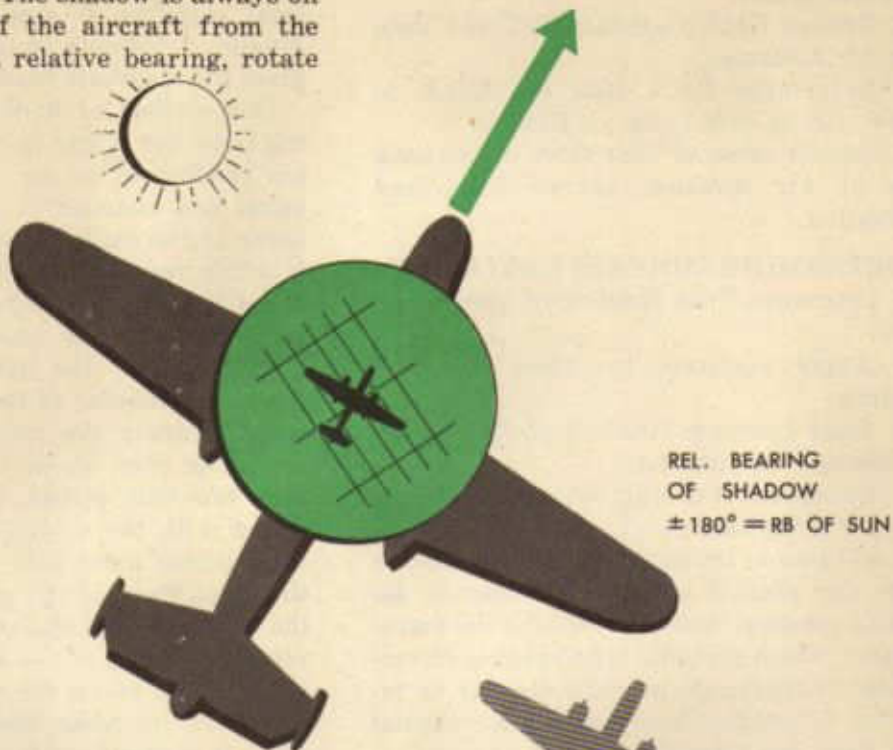

the driftmeter so the line of sight control projects toward the shadow, and the shadow is at the forward edge of the field of vision. Then adjust the driftmeter so the center grid line of the field bisects the shadow. The pointer reading of the driftmeter now shows the relative bearing of the shadow. To get the relative bearing of the sun, it is necessary to add or subtract 180° .

A visible sun and calm air is necessary when using the driftmeter to swing the com-



pass by celestial azimuth. A definite landmark is selected, and the airplane remains within a radius of 25 miles at all times during the swing. The steps may be summarized as follows:

IN THE AIR:

1. Read time, compass heading, and relative bearing of sun's shadow. An average of several readings may be taken. This must be repeated on at least eight heading.

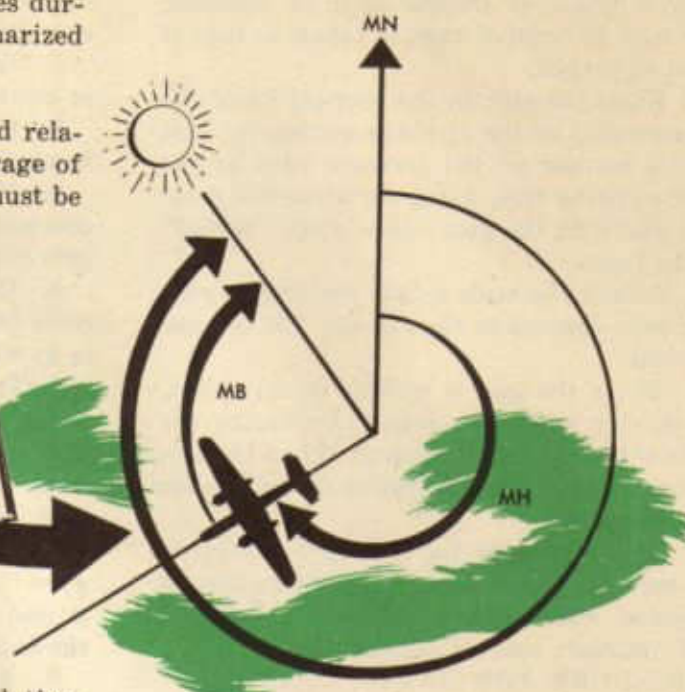

ON THE GROUND:

1. Use H. O. 218 solutions to find time bearing of the sun. Apply variation to find magnetic bearing. Make a graph of magnetic bearing of the sun against time. From this graph pick off the magnetic bearing of the sun for the time of each heading.

2. Magnetic bearing minus relative bearing equals magnetic heading of the aircraft. Magnetic heading minus compass heading equals deviation.

3. Complete compass card. Under certain conditions it may be desirable to make a graph of deviation correction against magnetic heading before completing the card.

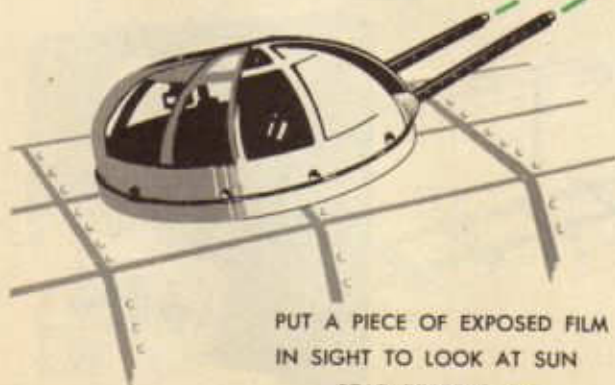

PUT A PIECE OF EXPOSED FILM
IN SIGHT TO LOOK AT SUN
READ BEARING OFF
STATIONARY RING

COMPASS SWING BY THE USE OF CALIBRATED GUN TURRET:

In case that the astro-compass is out of commission, another reasonably accurate means of obtaining deviation while in flight is by taking the relative bearing of a celestial body with the calibrated upper gun turret. This calibration can be done in about 30 minutes as follows:

1. Measure the circumference of the outer stationary ring of upper gun turret (approximately 10.5 ft.) with a piece of safety wire or non-stretchable material.
2. Convert the circumference into inches and divide the number of inches by 360. This will give the fractional part of an inch equal to one degree.
3. If a flat piece of spring steel long enough is available, measure and mark off



on it the interval representing each degree through 360 degrees to make the azimuth scale. A piece of thicker tape or masking tape may be used if care is taken so that it is not stretched.

4. Sight the gun on the vertical fin of the tail assembly of the airplane accurately, and place a pointer on the forward edge of the inner rotating ring, being sure that the point is in line with the gun sights when "zeroed" on the tail.

5. Attach the scale to the stationary ring with zero degrees to the aft and 180 degrees forward.

6. When the gun is sighted on an object, the pointer will move with it indicating the relative bearing of the object. When the sun is observed, a dense negative or sun shade must be used.

7. The procedure for finding deviation is the same as when using the driftmeter, as discussed above, knowing relative bearing, GCT, position, and compass heading.

PROCEDURE FOR SWING COMPASS BY GYRO:

NOTE: This method should be used when

the aircraft has neither B-3 driftmeter nor astro-compass installed. Select a day when the wind is less than ten miles per hour in order to avoid errors in reading heading.

1. Set magnetic bearing of road, railroad, or runway, etc., on gyro compass.

2. Have bombardier read drift using bombsight.

3. Have pilot fly down road, bombardier correcting pilot until the plane's longitudinal axis is parallel with the road.

4. Uncage gyro. (Gyro now reads magnetic heading of plane.) All radio equipment is to be turned on.

5. Turn to left and fly 12 headings 15° apart. (Completing half a circle.) Read gyro and compare with compass on each heading. Take the average of 3 or more readings on each heading. The difference is deviation.

6. Returning to calibration course, check gyro for precession. If it has precessed, reset it and distribute the precession error over the last six headings.

7. Fly 12 headings to the right, turning 15° by gyro on each heading.

8. Check for precession; figure deviation.

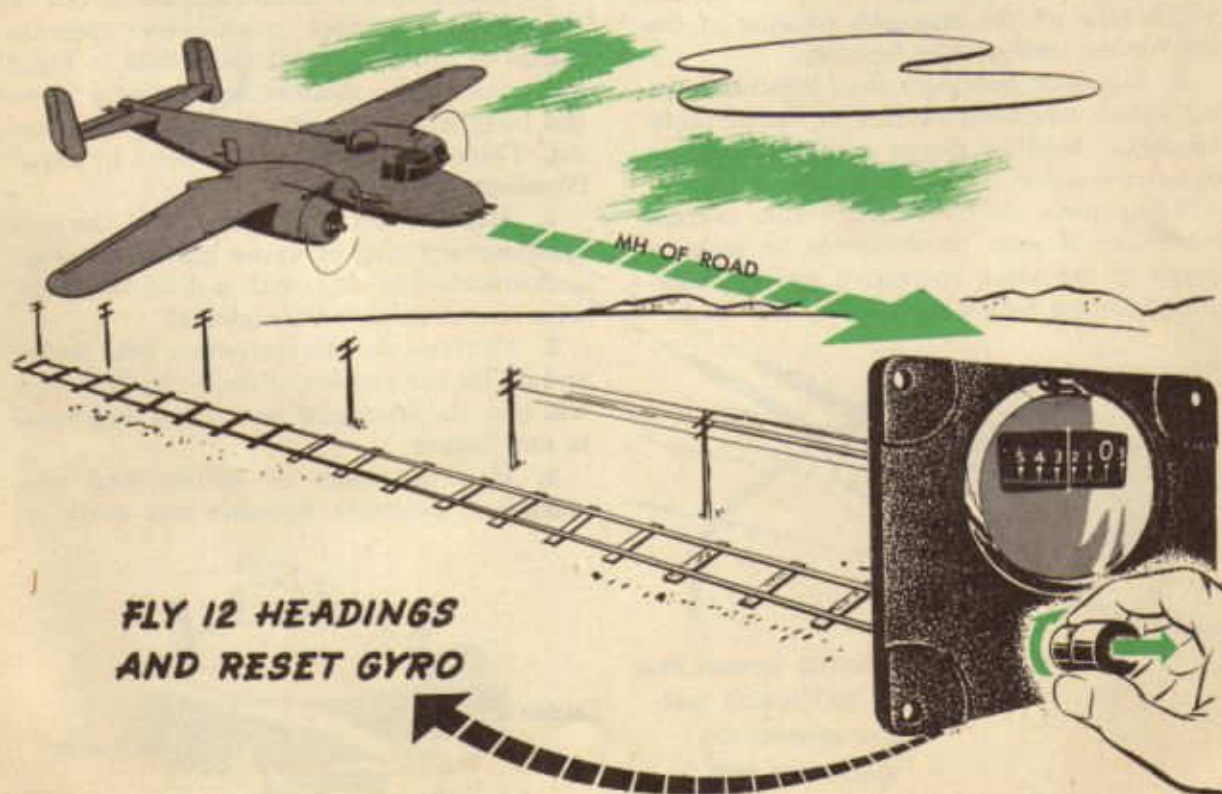

Pre-computation

Solution of the astronomical triangle by H.O. 218 provides a quick means of establishing a line of position. The LOP is determined by comparing the difference between the observed altitude and the altitude computed for a convenient position by H. O. 218. Another method, called Dreisenstock, or H. O. 214, can also be used as a shortcut. Ordinarily, however, these two methods fail to provide a calculated altitude for a particular position. When this information is desired, a solution known as Ageton, or H. O. 211, may be employed. Ageton solution for H_c and azimuth of a body is the most accurate that has been found, but it requires much more time to solve the triangle than H. O. 218. For this reason a variation of H. O. 218 has been developed to determine H_c and azimuth for any desired position.

In reality this variation involves in part the working of a H. O. 218 solution backwards. For numerous reasons it is necessary to know the exact altitude and azimuth of a body from a particular position at a definite time.

In general, the method for applying H. O. 218 to this problem is stated below; however particular attention must be paid to the various exceptions to the rule.

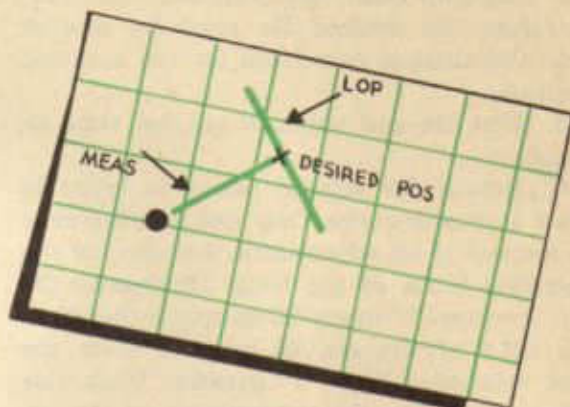

1. Work H. O. 218 solution, using an assumed position nearest the desired position. This minimizes error due to change of azimuth between the two positions.

2. Erect an LOP through the desired position from the azimuth, and measure the intercept along the azimuth between this LOP and the assumed position.

3. Determine whether the intercept is toward or away.

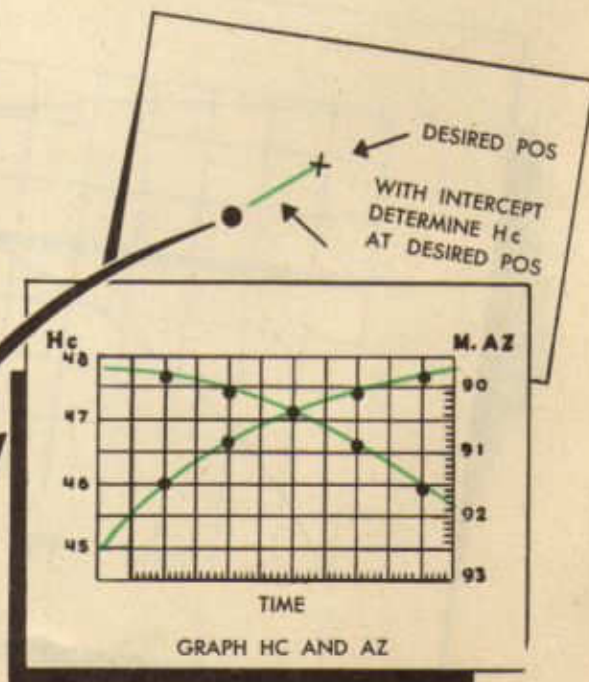
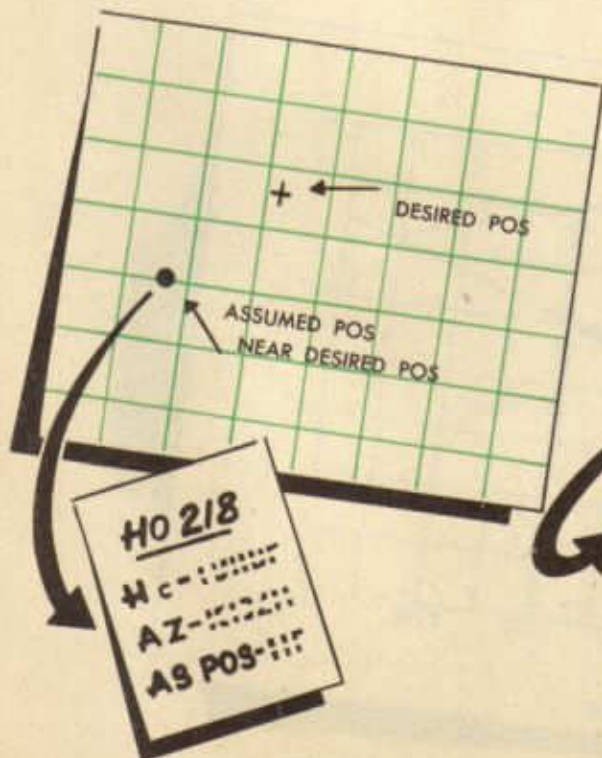

20 MINUTE INTERVALS

4. Apply the intercept expressed in minutes to the Hc to determine the Hc at the desired position. If intercept is away, it must be subtracted from the Hc. This means that the desired position is farther away from the subpoint than the assumed position; therefore the desired Hc must be smaller than the altitude calculated for the assumed position.

5. Plot Hc and azimuth against time on graph.

6. Repeat for several points in order to draw a smooth curve. Only one solution need be worked if an adjustment is made for the changing GHA of the body. Ordinarily the sun increases 5° every 20 minutes; therefore the LHA of the sun 20 minutes after the first solution will be 5° greater. With this information, the Hc and azimuth of the assumed position can be calculated and plotted and the Hc and azimuth of the desired position determined. Four points usually provide sufficient information from which to draw a curve.

Reference to the Air Almanac reveals that the GHA of the sun does not always

change 5° every 20 minutes, but it sometimes changes $5^\circ 01'$ during a 20 minute period. This necessitates the movement of the assumed position one minute to the west after the change occurs. This does not affect the accuracy of the curve. In many cases the GHA follows a constant rate of change for several hours; therefore, in reality very few movements of the assumed position is necessary.

If a star is to be used, the same method may be followed; however the rate of change of the GHA Υ is usually $5^\circ 01'$ for each 20 minutes of time. Therefore, the assumed position must be moved one minute westward for each 20 minutes of time. This movement need not be made when the GHA Υ changes only 5° , as it sometimes does.

If the Hc and azimuth of a body from a definite position have been calculated for intervals of twenty minutes over a period of an hour or so, it is possible to plot them against time and obtain a curve which represents all possible altitudes within the specified time. This type of curve, called *stationary* curve because the Hc and azimuth

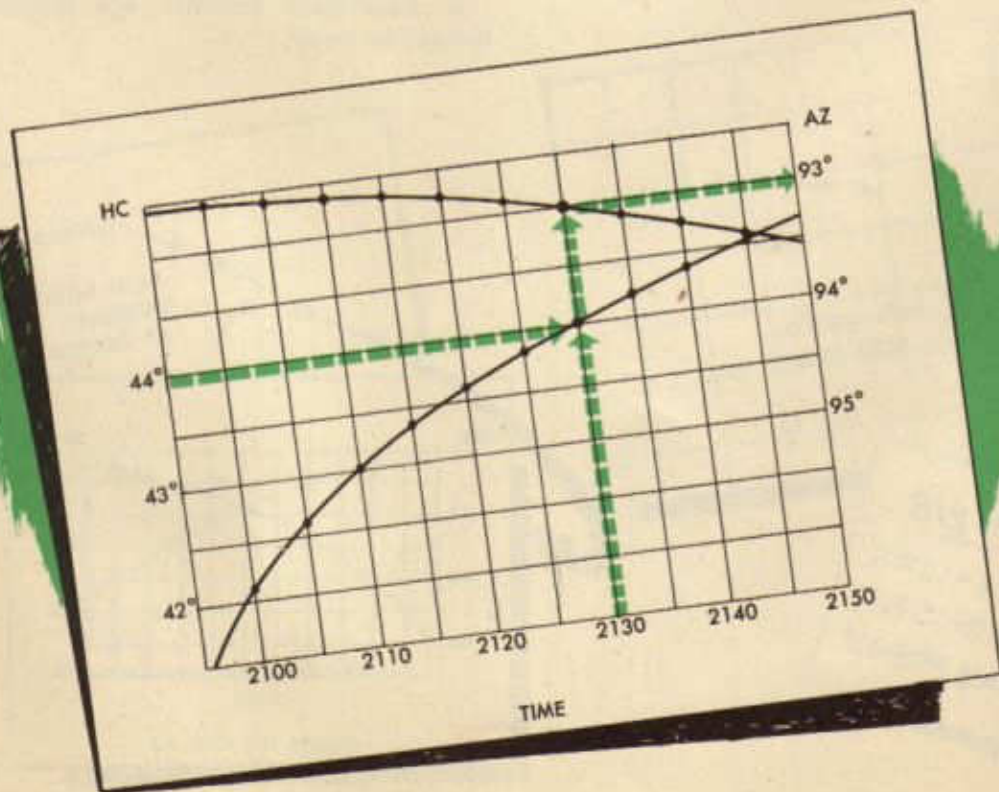

are calculated on one position, may be used to check chronometers and sextants, as well as to fly landfalls. It is a graphical representation of the change in altitude and azimuth of a celestial body over a given period of time, as seen from the definite position. The diagram shows that the Hc for 2130 is about 44°. The azimuth is about 93°. If the scale were sufficiently large, it would be possible to determine the altitude to the closest minute.

When the stationary curve is used to check chronometers, the exact correction for the sextant must be known. A curve is con-

structed including the time over which the check is to be made. Fifty to a hundred observations are made from the known position with the sextant and plotted on the graph. The curve is entered with the sextant observation, and the time that the body actually had that altitude is determined from

THIS Hc OBSERVED
WITH SEXTANT AT
21^h 20^m 30^s
CHRONOMETER TIME

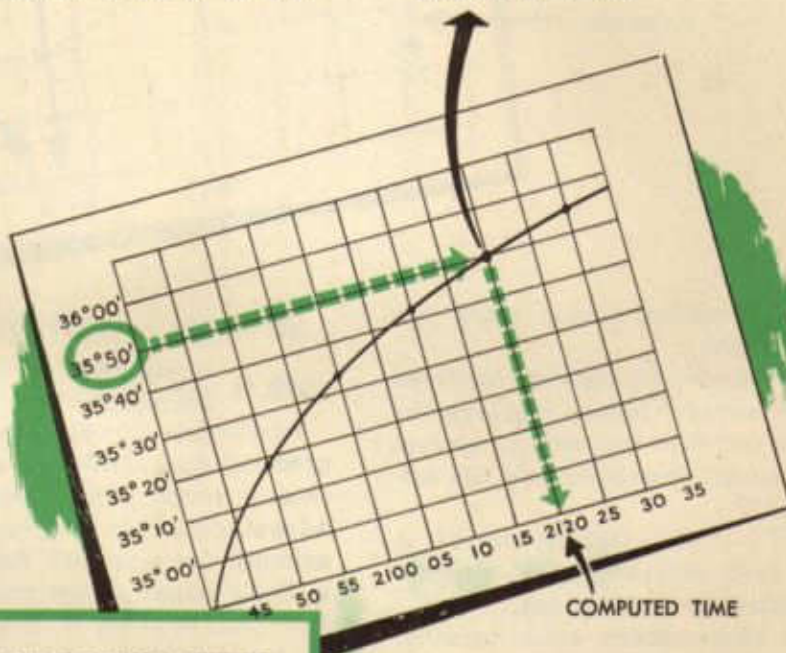

21	20	30	CHRONOMETER
21	20	00	COMPUTED
<hr/>			
-00	00	30	CORRECTION

TO BE APPLIED TO
CHRONOMETER

the time scale. These times are then compared with the time of the sextant observations and the differences noted. If the chronometer time of the sextant observation is greater than the time obtained from the graph, the sign of the difference is minus. These differences are added algebraically and divided by the number of observations. The correction thus obtained is applied to the chronometer time as the sign indicates.

When using the stationary curve as an aid in performing a landfall, the following procedure is followed:

1. Destination is taken as the position for which the solutions are worked.
2. The time of the curve is determined by the ETA plus at least 30 minutes or an hour.

3. H_c and azimuth are calculated for each 20 minutes of time.

4. H_c and azimuth curves are plotted against time.

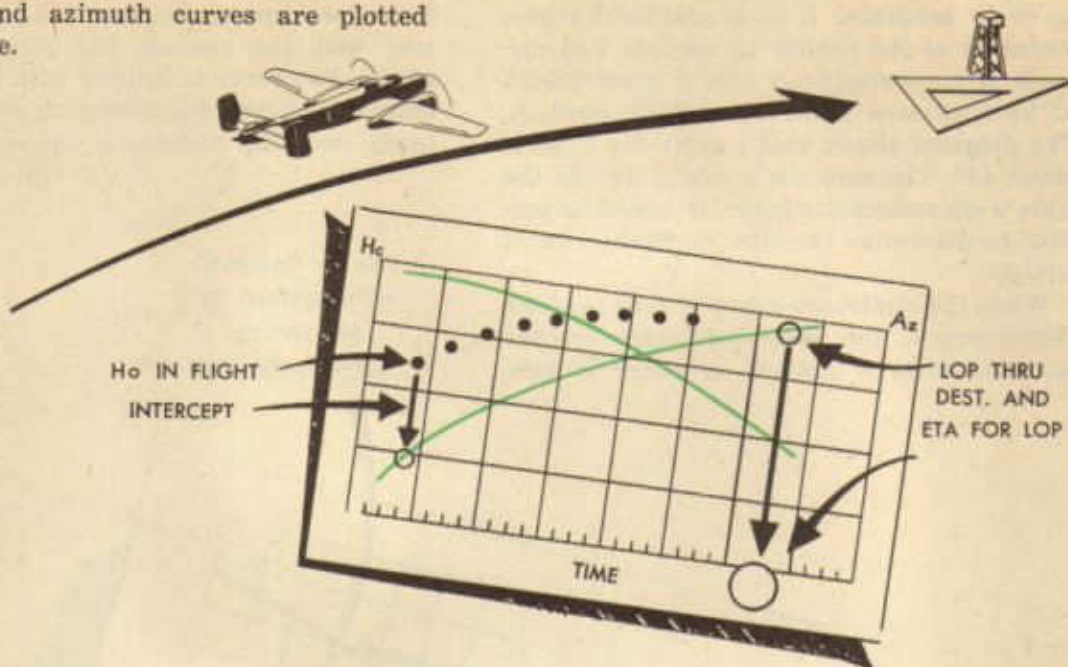

5. Altitudes observed during flight are plotted on the graph.

6. A curve is drawn through the observed altitudes a few minutes before reaching the H_c curve. This provides the time of arrival at the LOP through destination and the azimuth of that LOP.

7. At the ETA to the LOP, the aircraft is turned on the LOP (azimuth $\pm 90^\circ$, depending on the direction to destination).

8. Continue observations after turning. The following rules indicate whether or not the correct turn has been made.

$90^\circ + Az =$ curve falls below above when azimuth is increasing decreasing

$90^\circ - Az =$ curve falls above below when azimuth is increasing decreasing

Stationary curves are merely a means of precomputing altitudes and azimuths. Obviously, under certain conditions it becomes advantageous to precompute an H_c and azimuth for a specific future time. Normally these computations are used at the specified time; however if they should not be used at the intended time, the precomputation work need not be wasted. The A.N.T. book includes two tables with directions for use when adjusting for time.

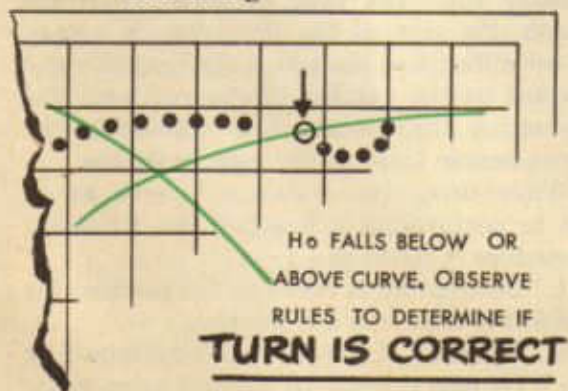

This series of H. O. 218 books and the American Air Almanac include other tables which the navigator may need to use at various times. Complete directions accompany sunrise and sunset, moonrise and moonset, dip, and coriolis force tables.

The Fix

A fix is a chart position corresponding to a ground position for a certain instant of time. It is obtained by various navigation methods, such as radio bearings, visual bearings and checkpoints, or celestial lines of position. Since each of these methods provides an indication of all possible positions of the aircraft at a given time, they may be termed lines of position. Each LOP is represented by a straight line, but in the case of celestial lines of position the straight line represents a segment of a circle of equal altitude circumscribing the subpoint of a particular body.

When an aircraft is located upon two or more lines of position which intersect, its position is said to be fixed at the point of

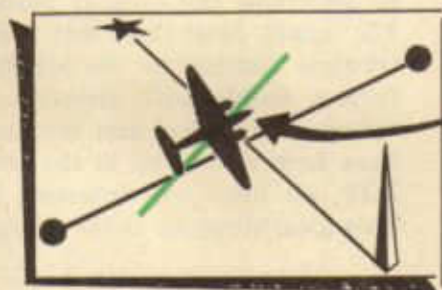
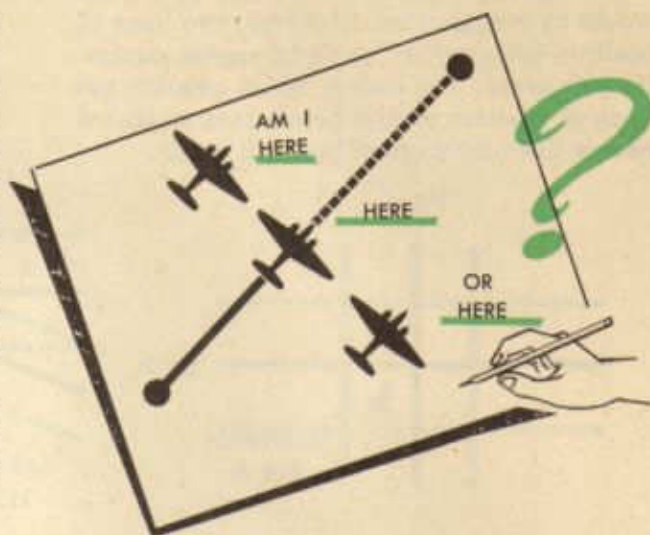

I AM ON BOTH LINES
SO I MUST BE
AT THE INTERSECTION

intersection. These lines of position may be obtained by visual, radio, or celestial means, and any combination of the three may be used to fix the position of an aircraft. When only one celestial body is visible, a fix may be obtained by crossing the celestial LOP with a geographic feature (river, road, coast-line, etc.) or a radio bearing. Two or more cele-

tial bodies may be used to establish a fix. In this case, however, it must be remembered that there are two possible positions since circles always intersect at two points if they intersect at all. But the chances of selecting the wrong intersection are slight since they are hundreds of miles apart. Even the simplest dead reckoning information establishes the approximate position of the correct intersection.



Two parallel lines will not intersect. Two lines nearly parallel finally intersect at a sharp angle. If one of such lines of position were slightly incorrect, the error of the fix would be exaggerated. However, two lines of position intersecting at right angles minimize this error. The bodies which provide the lines of position should be selected so that a course line and a speed line will result.

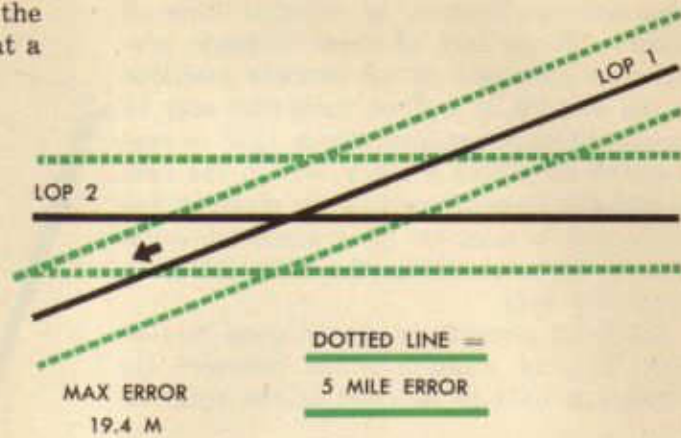
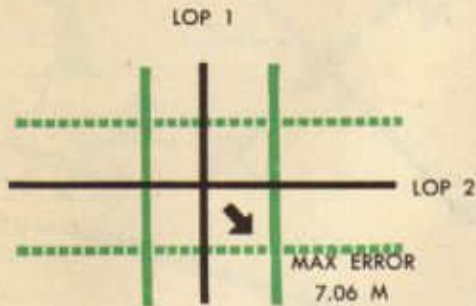

The course line is taken first since very little error results when it is moved up to the time of the speed line.

Three lines of position provide still greater accuracy. Ideally, the celestial bodies used

to determine the lines of position should be 120° apart. Most three star fixes give a small triangle similar to the windstar resulting from a double drift. However, if the observations are perfect and the lines of position have been moved up to the time of the last LOP, all lines will intersect at one point. This ideal situation is the navigator's dream.

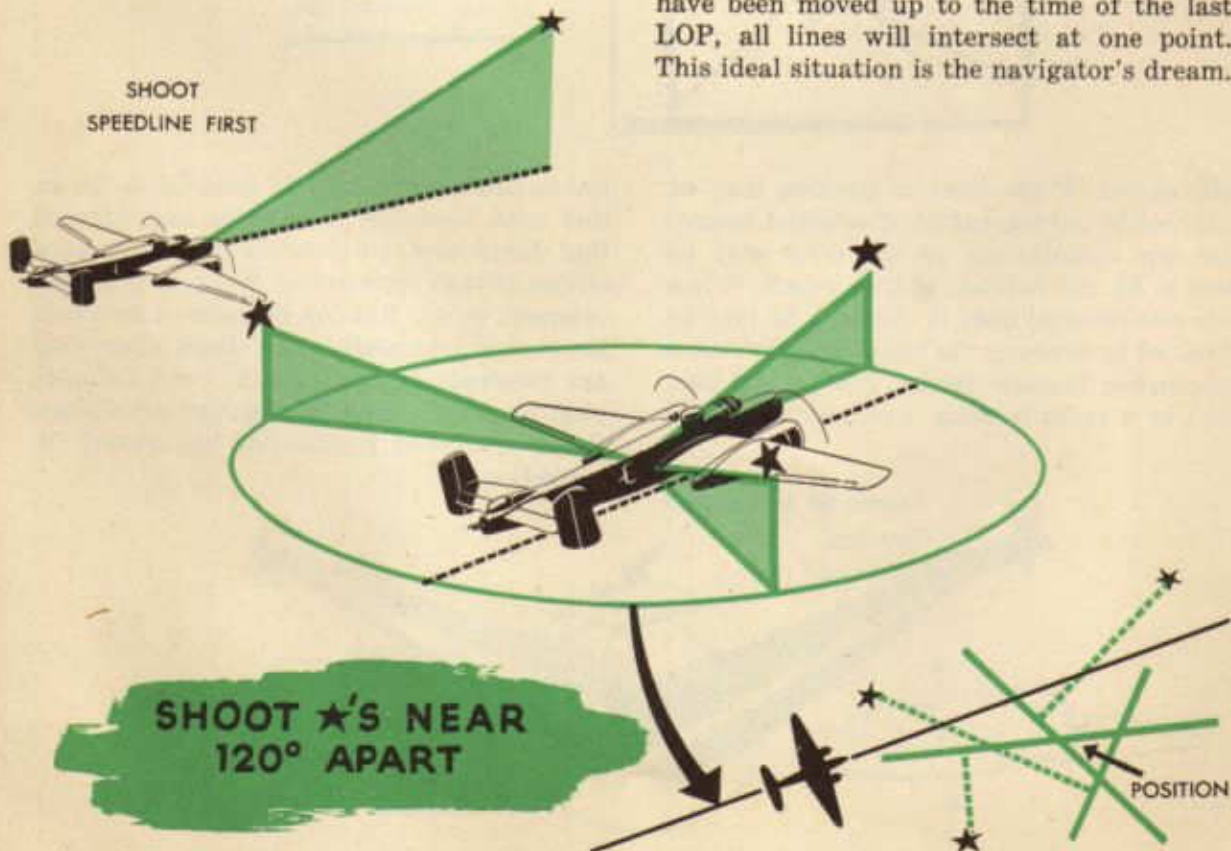

Fixes are usually obtained by observing the star and solving the astronomical triangles by H. O. 218. There are two other methods of solving the astronomical triangle which have come into common use. Star altitude curves for several selected stars may be printed and interpolated to obtain a fix. These curves may also be placed on a film strip and projected directly upon the navigator's chart by an instrument known as the astrograph. Star altitude curves and the astrograph have been developed as time-saving devices; however many navigator's still prefer to use H. O. 218 solutions to solve the astronomical triangle.

Several fixes taken during a flight provide an indication of the progress of the airplane over the surface of the earth. Proper interpretation of fixes is the problem which always confronts the navigator when using radio or celestial LOP's. This problem is com-

plicated by shifting winds and changing the aircraft's heading and airspeed. Accurate instruments provide a correct indication of true heading and true airspeed, but fixes must be used to interpret the wind velocity.

In order to understand fully the principle of wind interpretation, consider the following example in which all fixes are absolutely accurate.

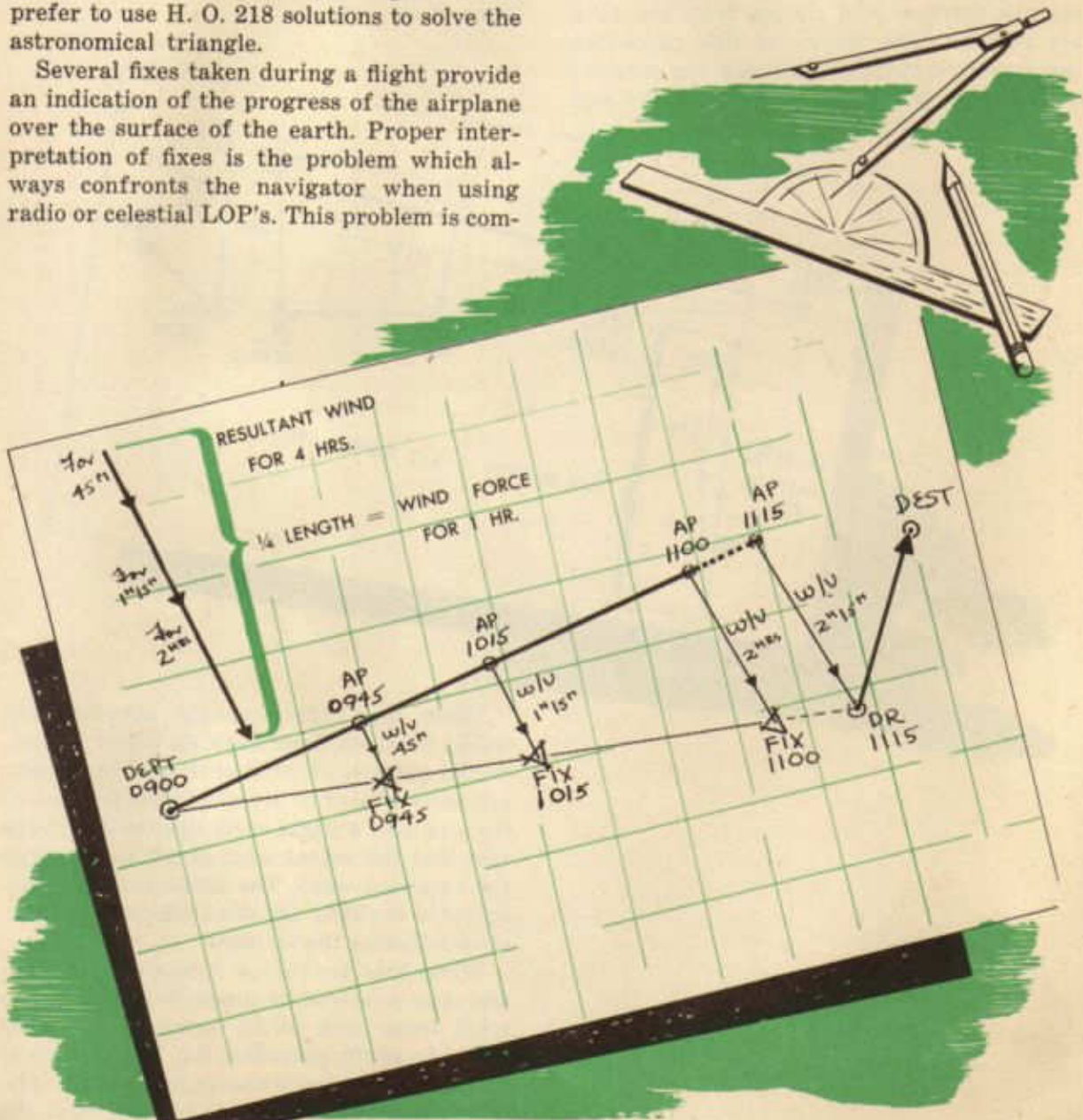

The case is unusual in that the wind does not shift; however it serves for illustrative purposes. The wind from each fix is in reality the average wind which has affected the aircraft from departure point to the fix; therefore as each wind is plotted separately head-to-tail for the total amount of time of each wind, a resultant wind is obtained. In the example, this total wind represents wind velocity for four hours. By simple proportion, the wind direction and force is easily found for one hour, and the effect of the wind for the required two hours and fifteen minutes may be obtained and plotted from the 1115 air position. The theory of this procedure involves a comparison between the position of the airplane relative to the air (AP) and

the position of the airplane relative to the ground (fix) at the same instant. Obviously the direction and distance between these two positions represents the wind velocity.

When fixes fall in such a manner as to indicate unexpected widely varying winds, an average should be used to determine the airplane's position. Winds may be averaged vectorially, thus finding the resultant wind velocity. This resultant wind is for the elapsed time of all the wind vectors and it must be weighted correctly and reduced to one hour's time by dividing by the sum of the time of all vectors.

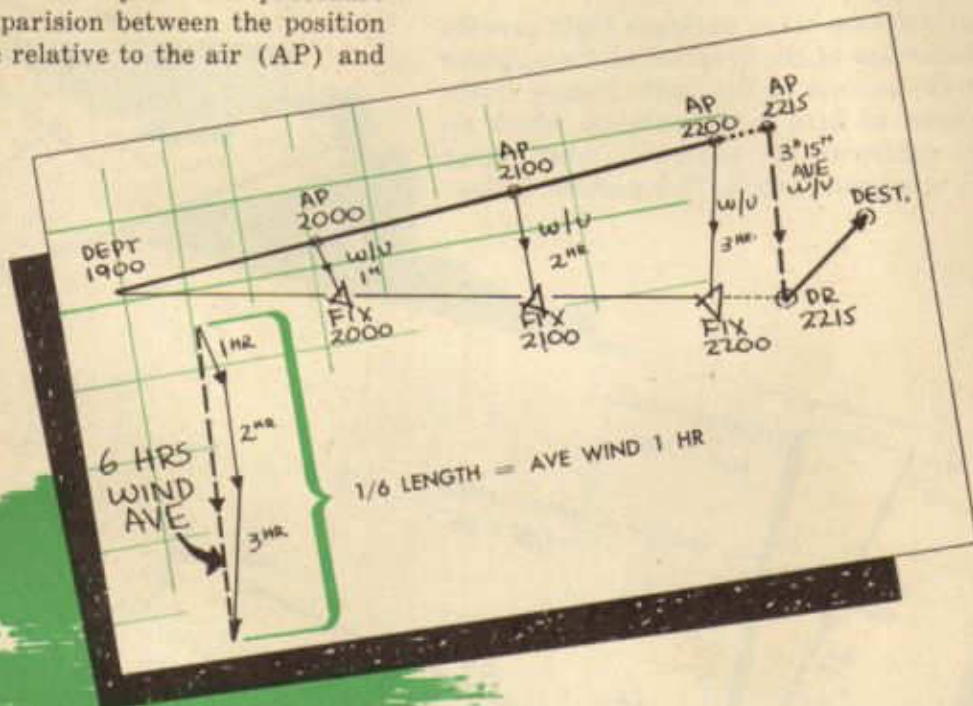

When fixes are normally accurate, the winds obtained from each fix follow the expected pattern of wind shifts. If the resultant wind is used to determine the position of the airplane, a slight error results, due to the fact that the actual wind is not the same as the resultant wind. The problem of the navigator is to obtain the wind which is immediately affecting the airplane.

When fixes are falling normally, this problem may be solved by properly analyzing the wind from each fix in terms of the wind found from the preceding fix. The essence of this interpretation is shown by diagram. The wind from the first fix is plotted from the

point of origin of the wind obtained from the second fix. Since the first wind represents the average wind for 45 minutes and since the second wind represents the average wind for this same 45 minutes plus 30 minutes more, or 1^h 15^m in all, the wind affecting the airplane between the fixes may be found by joining the loose ends to complete the vector triangle. This latter vector represents the wind which has affected the airplane between 2145 and 2215. It is the most recent wind, and it indicates a definite windshift when compared to the average wind for the first forty-five minutes. In fact, the shift is so large that another fix should be obtained quickly in order to ascertain whether or not the wind-shift actually occurred.

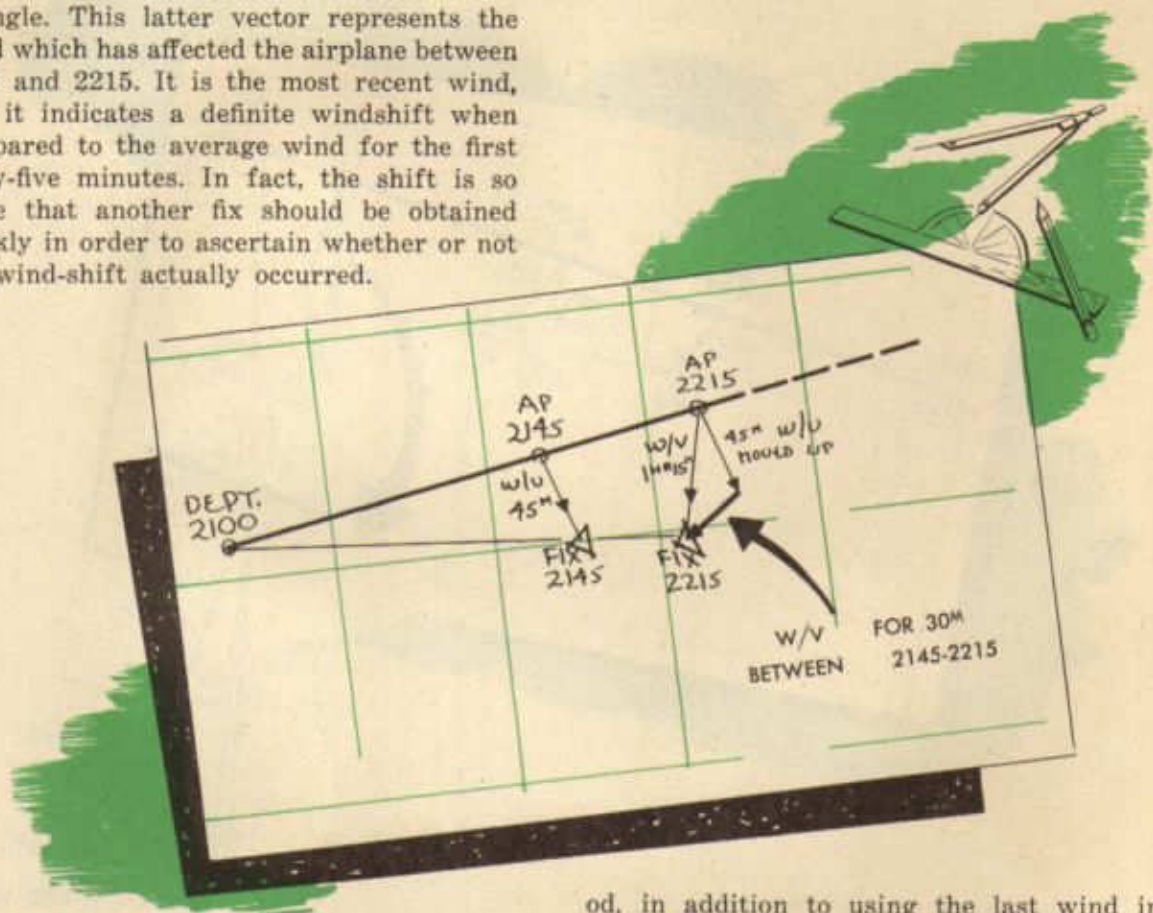

When the wind interpretation method is used, the actual groundspeed, based upon the latest wind as well as the average of the winds, produces the actual position of the airplane for the desired moment. Of course, the error which may creep into this method hinges upon the timing of the fixes. For example, the windshift which was found at 2215 may have occurred at any time between a few minutes before 2145 until nearly 2245. If fixes are taken as rapidly as possible, the margin for error is reduced to a minimum; consequently this fault, which is present in any method of navigation, is not too great. An added advantage of this meth-

od, in addition to using the last wind in part to determine the D. R. position, is that the latest wind is used to determine heading and E.T.A. to destination. It has been stated many times that wind-finding is the problem with which the navigator is most concerned. Wind interpretation is an aid to the solution of this problem since it provides an accurate method by which wind may be quickly analyzed.

Under ordinary conditions, when the fixes fall in such a manner as to indicate a gradual wind shift or any condition comparable to previous metro data, the wind from the next to last fix should be used to compare with the wind from the last fix. This produces a new wind for the shortest period of time. How-

ever, each wind should be compared to a previous wind in order to catch any unexpected change. This continuous comparison permits the proficient navigator to discard unreliable data.

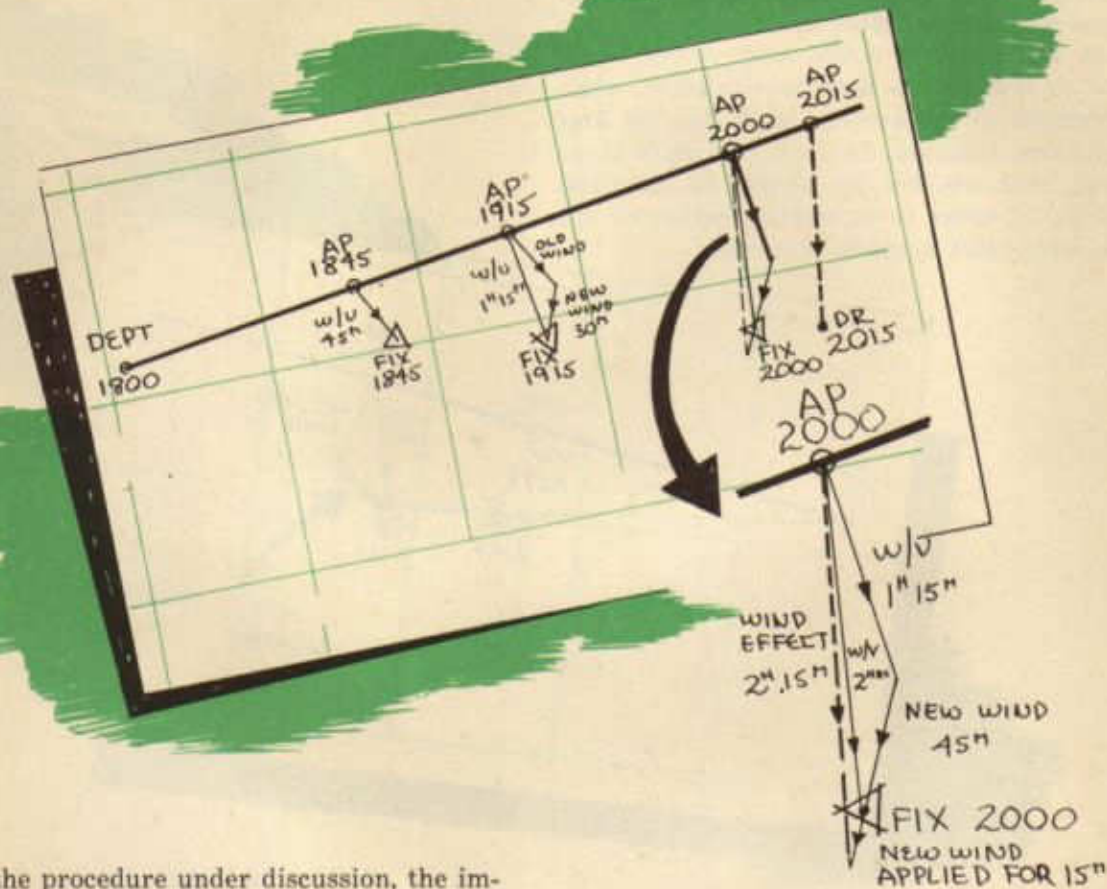

In the procedure under discussion, the importance of the last fix is apparent; therefore sufficient time must be allowed for taking another fix if one proves bad in the light of previous data. In any case it is important to remember that logical application of the available data indicates the information which should be used to calculate the DR position and to direct the aircraft to destination.

For long missions, more than six or seven hundred miles, the procedure differs somewhat. The navigator desires to know the latest wind in order to determine the position at any instant; therefore initial procedure follows that which has been described. Eventually, however, after several hundred miles,

the cumulative error becomes too great for navigational purposes; therefore the plot must be started over again by obtaining a position as accurately as possible. If a pinpoint is not available, good results may be obtained by taking three fixes within a few minutes of each other. If the results are reasonable on the basis of previous data and sequence of the three fixes, the plot may be begun anew at this point.

This procedure should be used when running off the Mercator in order to avoid having to refer to data which is on a different level of the map. Three fixes just before running off the Mercator will enable the navigator to start the plot from a new departure point shifted properly on his Mercator.

Three points in connection with the wind interpretation plot should be remembered:

1. Re-start the plot when a definite fix (by map-reading or at least three celestial fixes taken close together) is determined, to eliminate cumulative errors.

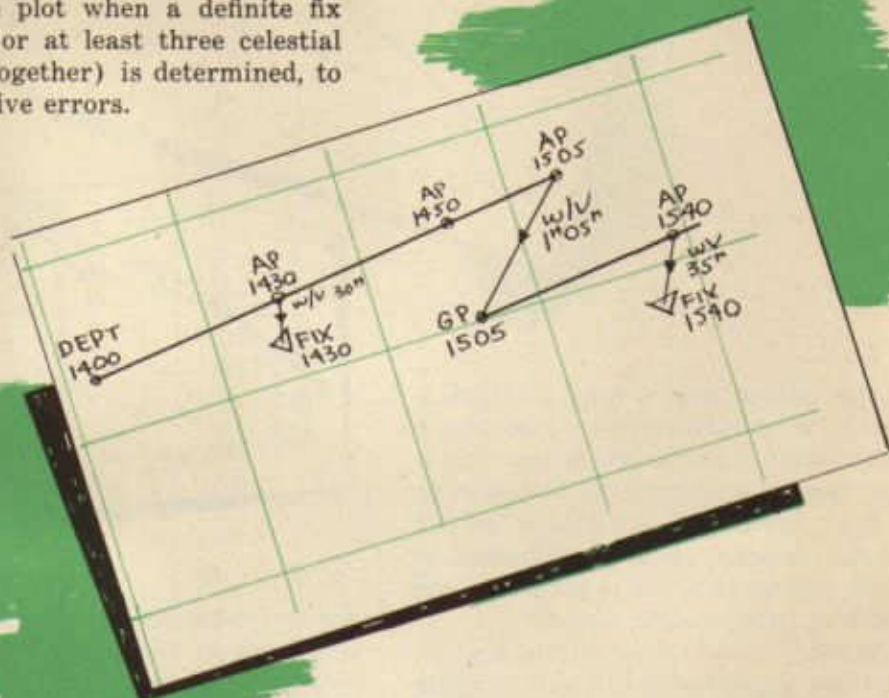

2. In using celestial fixes, before altering course, obtain at least two or three fixes, obtain winds from each fix, and use either the latest wind or a resultant wind to determine position and heading to destination.

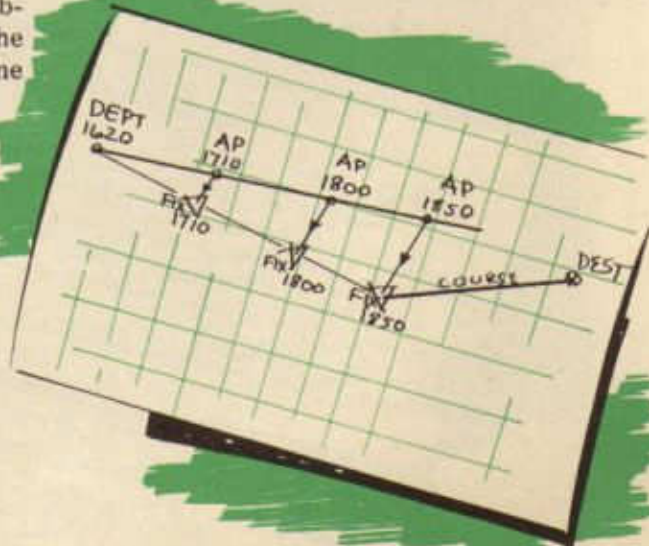

3. DR position may be determined instantly by applying wind for time elapsed to the air position.

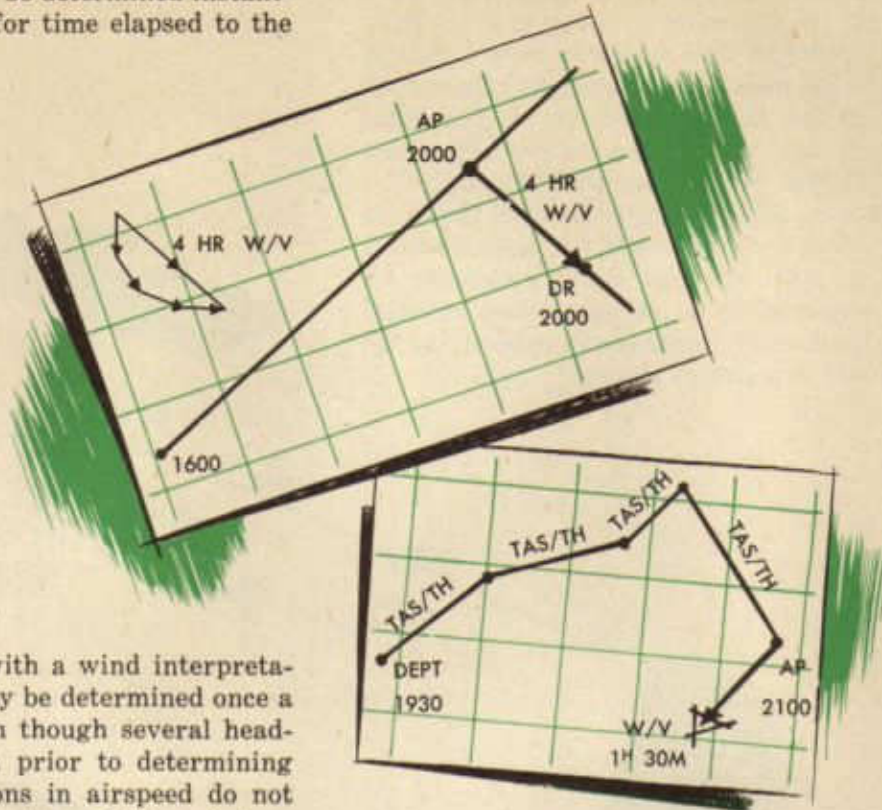

When navigating with a wind interpretation plot, the wind may be determined once a fix is established even though several headings have been flown prior to determining the fix. Also, variations in airspeed do not preclude the determination of the wind as long as the proper airspeed is used for each corresponding true heading vector.

The only inaccuracy in determining a wind, outside of the inaccuracies in the averaging and plotting of values, is due to the fact that the wind is not constant in direction or force over a long period of time. This fact is recognized in any form of navigation and

winds determined must be averaged or used separately if they vary a great deal in direction or force. The wind interpretation plot makes it possible to do either of these things.

LOG						REMARKS	
Mag Jack S Hunt						ALT SET 2992	
OR 1st Lt John Dunkle						TAKE OFF 1740	
celestial						FLT ALT 28000	
ALT	GR SPEED	RUN TIME	DIST	TO RUN TIME	DIST	ETA	ETA DEST
				500			
			2 ¹⁵	100		2015	
						Sun 17 58	
						HO 29°25'	
						AZ 225°	
						HC 29°15'	
						INT 10T	

