

MECHANICAL FAILURES AND PROCEDURES

EMERGENCY

LOWERING OF

LANDING GEAR

There are 4 ways to lower the gear on a B-24. It is seldom that all 4 fail. Recently a pilot flew around for 2 hours trying to figure out with an ignorant engineer how to get the gear down. Then, with 5 minutes of gas left, he executed a belly landing which did \$75,000 damage. Investigation showed that 60 seconds of know-how would have put the gear down.

Know all emergency procedures. Rehearse them with your engineer and copilot. Take an afternoon and crawl around the airplane with them. Read each procedure and dry-run it on the spot. That's the way to get acquainted with your airplane. Then, if an emergency arises, you'll be ready.

METHODS OF LOWERING THE LANDING GEAR

1. Normal hydraulic operation.
2. By use of the auxiliary hydraulic pump.
3. By use of the hand hydraulic pump, front star valve open, rear star valve closed.
4. Emergency hand crank method.

Important: First try all hydraulic methods of lowering the landing gear.

Know Your Landing Gear

Know whether the emergency landing gear lowering system in your airplane is **early design**, with cable connection between emergency hand crank and nose gear, or **later type**, without cable connection. Most airplanes of early design have been modified; check yours, and if it hasn't been modified, refer to Tech Orders for proper procedure. Successful emergency lowering of landing gear depends on this procedure.

Procedures applicable to later B-24 aircraft with emergency landing gear hand crank connected to main gear only.

LOWERING MAIN GEAR

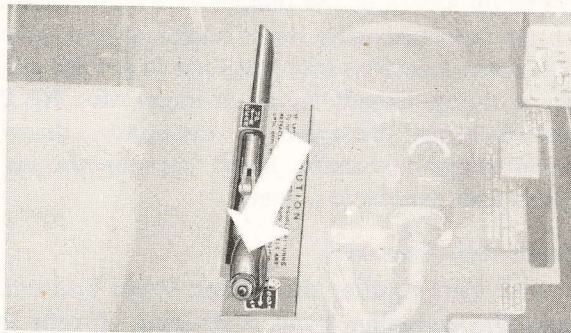

1. Place the landing gear control lever on the pilot's control pedestal in the "DOWN" position.

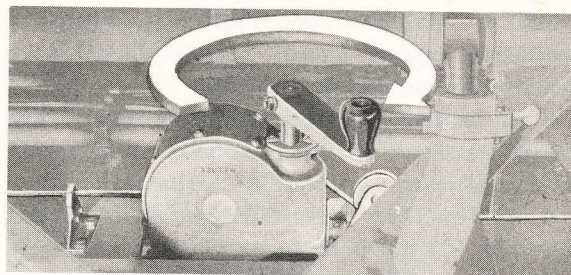

2. Turn the emergency hand crank clockwise until the main gear is down and locked. (This requires approximately 30 turns.) The crank is on the forward side of the front spar and may be reached from the extreme forward end of the bomb bay catwalk.

Note: In case one gear comes down and locks before the other gear is locked, and the tightness of the cable to the locked gear prevents any further rotation of the hand crank, loosen the turnbuckle on the tight cable and continue cranking until the other gear is completely down and locked.

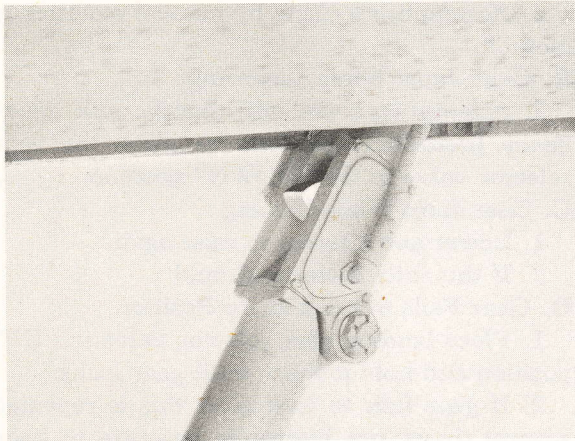

3. In addition to checking the landing gear warning light, check both wheels visually from waist gun windows to see that they are down and locked. (Flaps must be full up to permit this check.)

4. Return landing gear control lever to neutral.

Re-setting Procedure

To re-set the emergency lowering system, turn hand crank approximately 30 turns counter-clockwise to normal position. Avoid cranking too far and allowing the cable to jump off the drums. Resafety the crank.

LOWERING NOSE GEAR

1. Place landing gear lever in the "DOWN" position.

2. Enter nosewheel compartment (on some aircraft it is necessary to remove the draft cur-

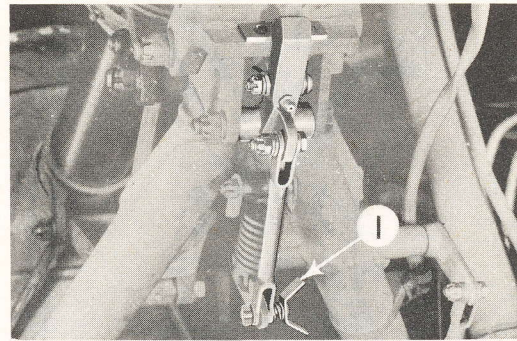

tain to get at the nose gear) and remove the butterfly pin (1) from its normal position.

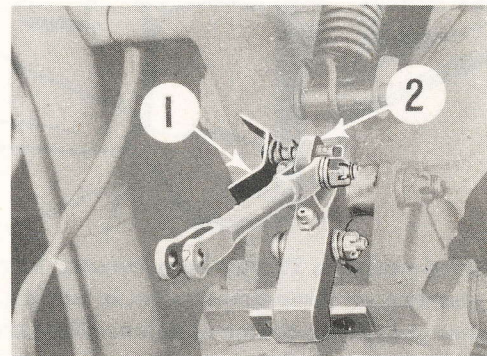

3. Insert the butterfly pin in the eye of the latch linkage (2).

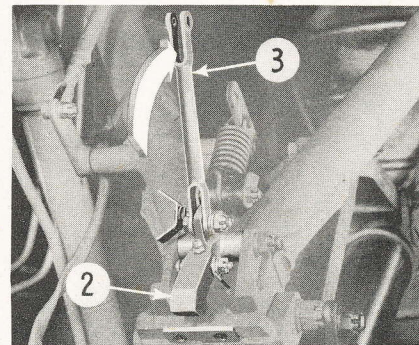

4. Release the nose gear latch by pushing up on the drag link (3).

5. Take a sitting position near the top of the shock strut. Grasp the top of the strut with both hands and lift upward to force the gear into the

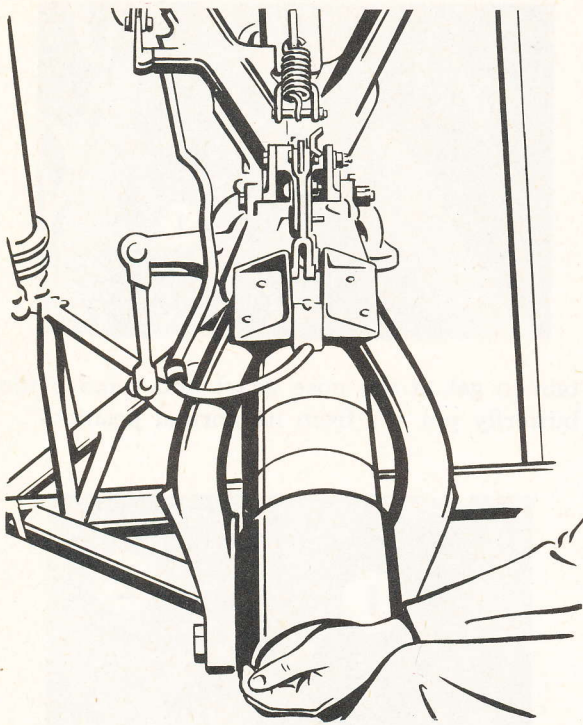

extended position. It may be necessary to rock the gear two or three times to get it moving. As the gear passes the center of balance, be careful to keep hands and arms clear of the gear assembly.

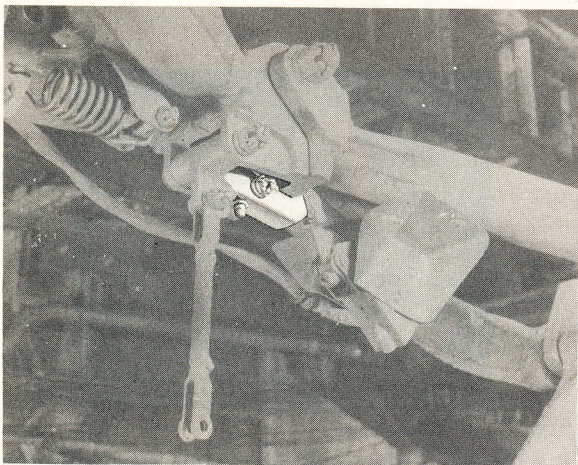

6. After the gear falls, make sure the lock is secure. If it is not securely locked, push upward on the lock assembly.

Note: Replace the butterfly pin as soon as possible after landing.

MAIN GEAR FAILURES

NOTE: Try hydraulic operation several times before resorting to mechanical methods.

A. Gear Fails to Lock Down

1. Hold landing gear selector valve down. **If this fails to lock gears:**

2. Accomplish locking by manual emergency method.

B. Gear Jams While Lowering

1. Attempt to lower with hand crank emergency procedure. Be sure to place the gear selector valve in the "DOWN" position.

C. Gear Jams While Raising

1. Lower and attempt to raise again.

2. If this fails, lower and land.

D. Gear Fails to Lock in Up Position

1. Place landing gear selector valve in "UP" position and hold it there until gear locks.

2. If gear fails to lock after this is repeated several times, use hydraulic pressure to keep gear in the up position. If necessary, return selector valve to "UP" position frequently to prevent gear from slipping down too far. (Not recommended on long flights.)

E. One Gear Sticks Up and Will Not Lower

1. Raise lowered gear and attempt to lower by emergency procedure. If this fails, land as described in "Landing With One Main Gear and Nose Gear Extended, One Main Gear Retracted."

F. Gear Fails to Raise (No. 3 Engine Fails on Takeoff)

1. Turn the auxiliary hydraulic pump on. Switch is located on forward face of bulkhead No. 4.2, right side of fuselage.

2. Open emergency hydraulic (star) valve aft of Station 4.1, right side of fuselage.

NOSE GEAR FAILURES

Caution: All men should be out of nose gear compartment while nose gear is being raised.

A. Gear Fails to Raise (No. 3 Engine or Hydraulic Pump Fails on Takeoff)

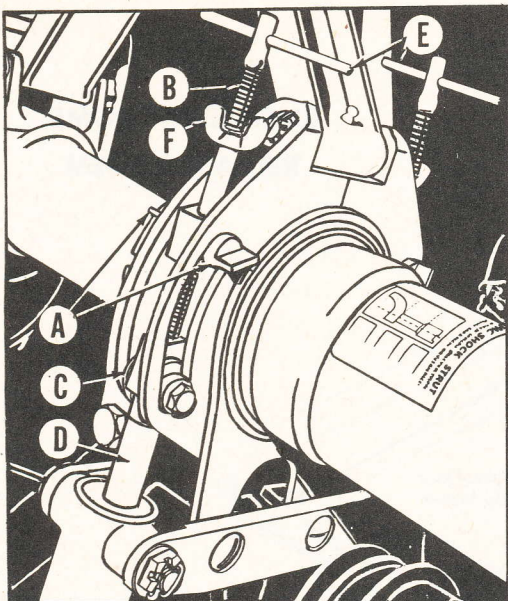

1. Turn on main switch for auxiliary hydraulic pump.

2. Open emergency hydraulic (star) valve.

B. Gear Fails to Lower

1. For early type B-24's check setting and safetying of:

a. Emergency dump valve (slotted lever should be in vertical position).

b. Over-travel lock pin (pin must be in shallow grooves, **not** in deep slot). Pin is located under flight deck, Station 3.0, left side of fuselage.

2. Premature kick-out of landing gear selector valve:

a. Overpower until operation is completed.

b. On ground adjust pressures to 850 lb. sq. in. for "DOWN" and 1100 lb. sq. in. for "UP."

C. Accumulator-Type Shimmy Damper Failure: If nosewheel accumulator pressure falls below 150 lb. in flight, install emergency nosewheel lock before landing, as follows:

1. Remove valve cap on bottom of nosewheel accumulator and deflate accumulator completely.

2. Remove shoulder bolts "A" from locking screw assembly "B."

3. Place head of screw assembly "C" over end of damper shaft "D."

4. Force damper shaft into damper and insert two shoulder bolts "A" into block of screw assembly.

5. Repeat accumulator deflation operation (Step 1).

6. Repeat Steps 2, 3, and 4 for installing screw assembly on opposite side of nose gear.

7. Screw handles "E" in as far as possible.

8. Tighten wing nuts "F."

9. Extend nose gear and land.

Caution: Remove locks at end of landing roll and have airplane towed to parking area.

D. Houdaille Shimmy Damper Failure

1. There is no present means of locking this type of shimmy damper. In case of failure, make a nose-high landing just as if you had no brakes or had a damaged nosewheel.

Caution: Don't lower nose until airplane stops. Then lower gently and have the ship towed to parking area.

EMERGENCY BOMB RELEASE SYSTEM

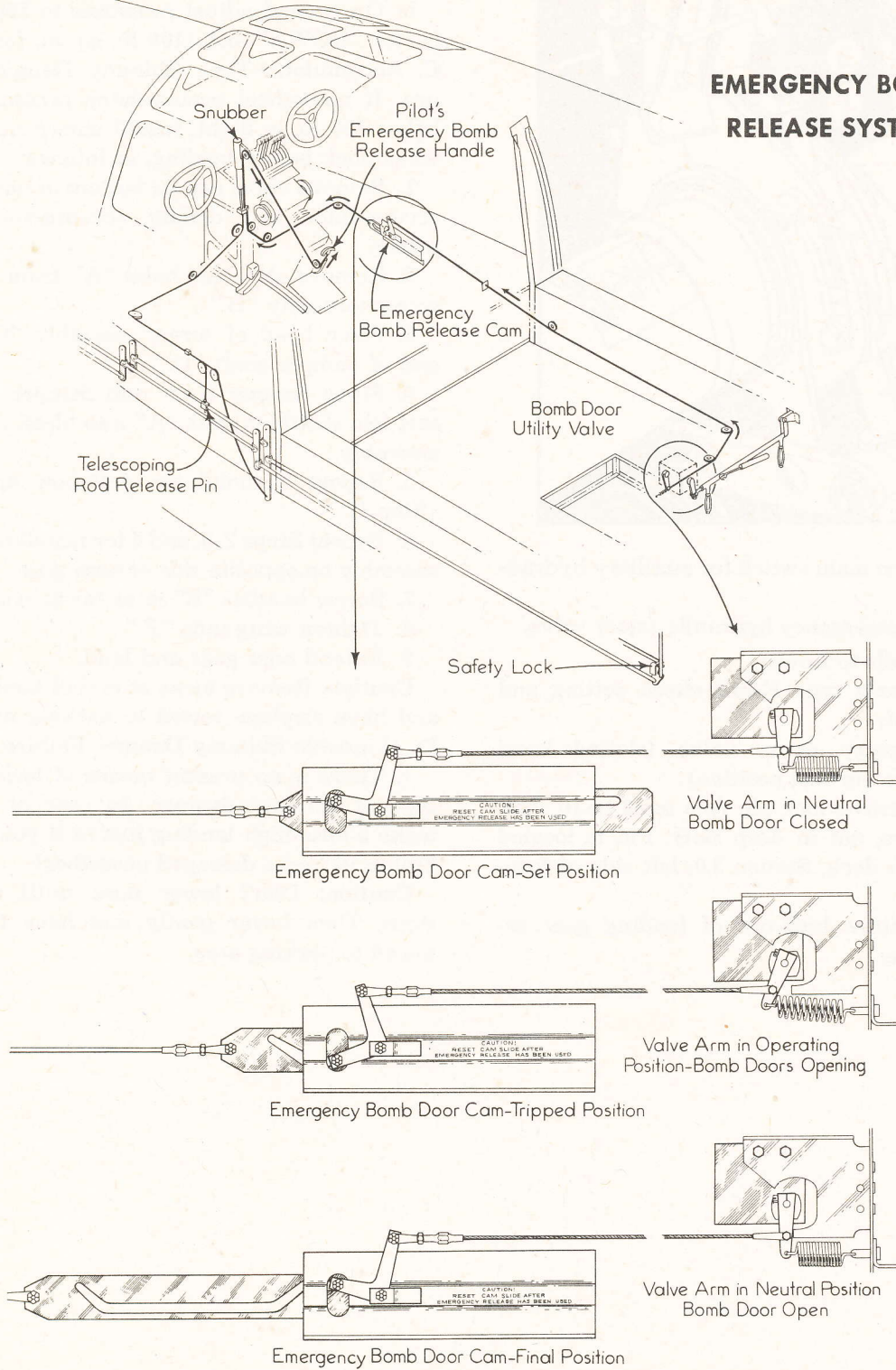

EMERGENCY BOMB RELEASE OPERATION

A. To Salvo Bombs

1. Pull pilot's emergency bomb release handle at rear of pedestal up approximately 4 inches, pause momentarily until bomb doors are completely opened (notice red light on instrument panel). Continue pulling upward to release bomb load.

B. Re-setting Emergency Release

After emergency release of bombs by pilot, the system must be re-set in order to place bomb release system in operating condition and to close bomb bay doors. On late series aircraft, however, you can close bomb bay doors without re-setting the system.

1. Place release handle in socket on control pedestal.

2. In nosewheel compartment, take up slack in cable at cam located on right side of compartment between Stations 1.2 and 2.0.

3. Grasp cam at cable end and shove in until cable is tight, which allows bomb door utility valve to return to neutral position.

4. In the same compartment on left side of ship, between Stations 1.2 and 2.0, re-set emergency telescoping rod by replacing pin so that release system will function normally.

EMERGENCY BOMB DOOR OPERATION

A. To Open When Hydraulic System Fails

1. Move any bomb door release handle to "OPEN." (If you use bomb door emergency and utility (auxiliary) valve, under flight deck at Station 4, right side of fuselage, it must be held in "OPEN" position until procedure is completed.)

2. Pull hand cranks out of stowage clips, engage, and turn according to stenciled arrows on bulkhead. Location—Station 5.0, one crank on each side of catwalk.

B. When Doors Open Partially and Stop

1. Check door tracks for possible obstructions.

2. Check bomb door mechanism, which might be out of alignment.

C. When Doors Open Partially and Control Lever Returns to Neutral Position

1. Overpower selector valve until doors are open.

2. On ground adjust kick-out pressure of selector valve to 600 lb. sq. in. "OPEN," 1000 lb. sq. in. "CLOSED."

Caution

**AT ALL TIMES STAY CLEAR OF
BOMB BAY DOOR AREA WHEN
DOORS ARE BEING OPERATED.**

EMERGENCY WING FLAP OPERATION

A. Emergency Hand Pump Operation (Located to Right of Copilot)

1. Place flap selector valve in "DOWN" position.

2. Break safety wire on needle valves with hand pump handle—then close forward valve and open aft valve.

3. Operate pump approximately 74 strokes or until pump locks to lower flaps, observing position of flaps on the indicator.

4. If indicator shows flaps down, but pump does not lock, investigate lines for leaks. Pump must lock or flaps will not be down and will creep up.

5. When flaps are completely lowered, return selector valve to neutral position.

Before Flaps Can Again Be Operated Normally, the Following Must Be Done

1. Both the needle valves should be left open for approximately one minute to dissipate the pressure accumulated in the small emergency flap line, thus allowing the piston within the shuttle valve to return to normal position.

RESTRICTED

2. If flaps cannot be raised, indicating shuttle valve sticking, put wing flap selector valve in "DOWN" position for a few seconds to break shuttle valve loose, and then return selector valve to neutral.

3. After this one-minute period the aft valve can be safetied in the closed position and the flaps operated normally.

B. Failure of Engine-driven Pump Only

1. Turn on emergency hydraulic (star) valve.
2. Turn auxiliary hydraulic pump switch on.

C. Premature Kick-out of Selector Valve

This is caused by too low a pressure setting or cold, congealed hydraulic fluid.

1. Overpower selector valve until operation is completed.

2. On ground adjust pressure settings to 750 lb. sq. in. for up operation, and 450 lb. sq. in. for down operation.

Caution: Do not lower flaps at speeds in excess of 155 mph IAS.

NOTE: Be sure both needle valves are open and flap selector valve is in neutral at same time. These valve settings then allow free passage of the fluid in the emergency line back to the reservoir.

HYDRAULIC SYSTEM FAILURES

A. Failure of Engine-driven Pump and Auxiliary Hydraulic Pump

Use emergency hand pump located to right of copilot's seat. Forward valve open; aft valve closed. This operates bomb bay doors, wing flaps, and landing gears by pumping fluid through unloading valve and open center system and it charges accumulators, thus providing pressure for brakes.

B. Engine-driven Pump Fails to Operate

Open emergency hydraulic (star) valve and be sure auxiliary hydraulic pump switch is "ON."

C. Hydraulic Lines Broken or Leaking

Broken Lines: To prevent loss of fluid temporarily, squeeze and fold back end of tubing with pliers.

Broken Pressure Line (Right Wing Front Spar):

1. Cut No. 3 engine and feather propeller immediately.
2. Disconnect line between suction check valve and engine-driven pump.
3. Turn on emergency hydraulic (star) valve and start auxiliary hydraulic pump.
4. Turn emergency reservoir valve to vertical position until reservoir can be replenished. Then return valve to normal, horizontal position.
5. Put No. 3 engine back into operation.

Leaking Lines: Excessive leaking can be remedied by tightening fittings with a tubing wrench. **Caution:** Do not tighten beyond safe limits.

D. Unloading Valve Sticking in Flight

Cause: Foreign particles or broken spring.

1. Gently tap valve with mallet to give free movement of pistons.
2. In case of broken spring, the auxiliary hydraulic pump must be used to charge the accumulators.

E. Hydro-electric Constant Pressure Switch Intermittently Cutting In and Out

Cause: Leak in accumulator or auxiliary pressure lines or faulty accumulator check valve. This condition should be corrected or it will result in fusing of points in switch.

1. Make certain emergency hydraulic (star) valve is tightly closed.
2. Check for possible leaks.

F. Bomb Door Emergency and Utility Valve Fails to Return to Neutral, Causing Hydraulic System to Chatter Violently

Reach in under radio deck and return valve handle to neutral manually. Spring return is probably not working.

G. Upper Part of Hydraulic Fluid Reservoir Leaking

Turn emergency reservoir handle (suction valve) to vertical position.

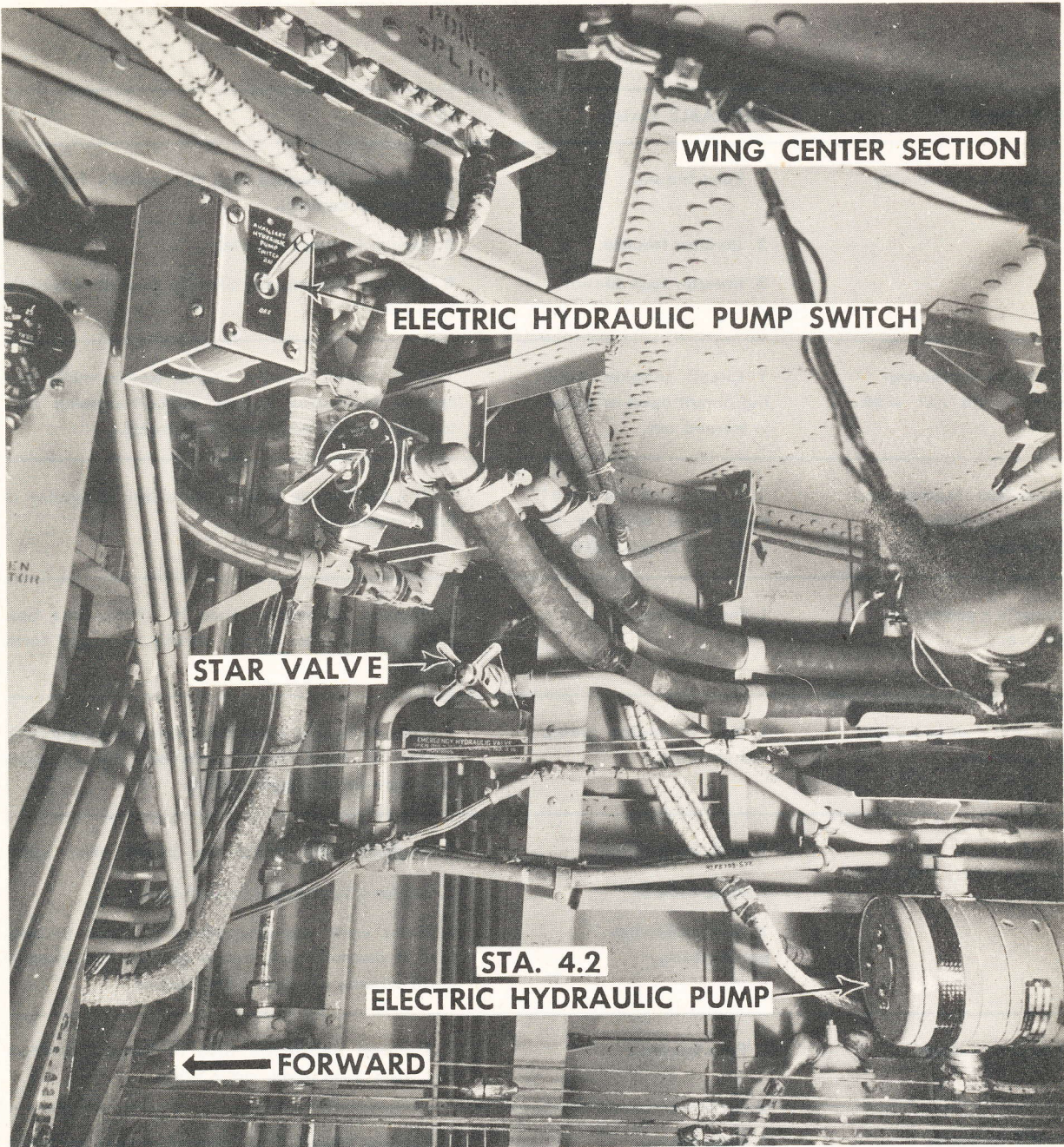

Caution

If open center system pressure line on reservoir side of engine pump check valve is shot out, the system won't work except by hand-pump lowering of wing flaps and accumulator discharge.

ELECTRICAL SYSTEM FAILURES

SYMPTOM	PROBABLE CAUSE	REMEDY
Autosyn instruments go dead.	<ol style="list-style-type: none"> 1. Fuse blown. 2. Inverter trouble. 3. Inverter fuse blown. 	<ol style="list-style-type: none"> 1. Replace 2-ampere fuse in copilot's fuse box (at right of copilot). 2. Switch to other inverter. 3. Replace 30-ampere Slo-Blo fuse in copilot's fuse box.
Propeller feathering buttons do not work.	<ol style="list-style-type: none"> 1. Circuit breaker holding circuit open or circuit is burned out. 	<ol style="list-style-type: none"> 1. Hold circuit breaker button down while operating feathering button. (Circuit breaker buttons are red buttons top of pedestal.)
Propellers feather and unfeather without stopping.	<ol style="list-style-type: none"> 1. Pressure cut-out switch not working, or wire to it is grounded. 	<ol style="list-style-type: none"> 1. Pull feathering button out when propeller is fully feathered.
Propeller governor failure.	<ol style="list-style-type: none"> 1. Fuse blown. 	<ol style="list-style-type: none"> 1. Replace 10-ampere fuse in pilot's fuse box (left of pilot). Do <u>not</u> flip switch back and forth quickly.
Hydraulic gages show no pressure.	<ol style="list-style-type: none"> 1. No. 3 engine pump not working. 	<ol style="list-style-type: none"> 1. Turn on toggle switch for auxiliary hydraulic motor—in right front bomb bay on crossbar high up—large toggle switch.
Landing gear down lamp (green) does not light.	<ol style="list-style-type: none"> 1. Bulb burned out. 2. Fuse blown. 3. Micro switches not working. 	<ol style="list-style-type: none"> 1. Replace with spare on panel near light. 2. Replace 10-ampere fuse in fuse box. 3. Have crew member visually check to see, first, if nosewheel is down and latched; then if main wheels are down and locked.
Interphone dead.	<ol style="list-style-type: none"> 1. Fuse blown. 	<ol style="list-style-type: none"> 1. Replace 10-ampere fuse in liaison junction box, right side under radio table.
Radio compass receiver dead.	<ol style="list-style-type: none"> 1. Fuse blown. 2. Inverter fuse blown. 3. Inverter trouble. 	<ol style="list-style-type: none"> 1. Replace blown 5 or 10-ampere fuse (or both) in radio compass splice box on aft support of radio compass unit, and 5-ampere fuse in copilot's fuse box. 2. Replace 30-ampere Slo-Blo fuse in copilot's fuse box. 3. Switch to other inverter—switch on pedestal, lower left side. Also check inverter relay in box near inverter under flight deck.

SYMPTOM	PROBABLE CAUSE	REMEDY
Command radio receiver dead.	1. Fuse blown.	1. Replace fuse at modulator dynamotor unit. (There are two 20-ampere fuses under removable covers on the base, with spares on the opposite side.)
Liaison radio transmitter dead.	1. Fuse blown.	1. Warning: Turn switch off first. Voltage in this unit is dangerously high. Replace power fuse—there are 2 cartridge-type fuses, one 30 and one 60 ampere, and a 1000-volt fuse in the output circuit of the liaison dynamotor at rear right of radio compartment. Remove cover to reach fuses. Liaison transmitter 1000-volt fuse is reached by removing tuning coil section. Fuses are inside and above space for tuning unit.
Liaison receiver dead.	1. Fuse blown.	1. Replace fuse. Remove 2 knurled nuts on front of receiver and slide out receiver; 5-ampere fuse is on lower right hand side. There are no spares in receiver. (Receiver is normally sealed.)
Bombing interval control dead.	1. Fuse blown. 2. Interval control defective.	1. Replace 15-ampere fuse inside bomber's panel. 2. Remove interval control plug and release bombs manually.
Cannot release bombs electrically.	1. Bomb door switches open. 2. Voltage too low.	1. Check bomb doors—must be full open. Check fuse in Station 4.0 fuse box. 2. Check voltage at power panel on rear bulkhead of flight deck. If low (below 24 volts) cut off all possible electrical equipment. See item below.
Lights dim. Motors slow to start. Motors noisy. Interphone weak. Radios weak or dead. Inverter power weak and inverter action erratic. Bomb release interval control dead.	DC Voltage Low	1. Check voltage of each generator at power panel. 2. Switch off any dead generator. 3. Switch off all electrical units not absolutely necessary. 4. Start auxiliary power supply unit. Equalizer switch may be turned on if engine generators are working. 5. Look for and switch off any electrical unit damaged, shorted, heating badly or obviously defective. 6. Adjust voltage regulators to maximum. Note: The above operations are to be tried in order, not going further when the trouble clears up.

BAILOUT DITCHING AND FIRES

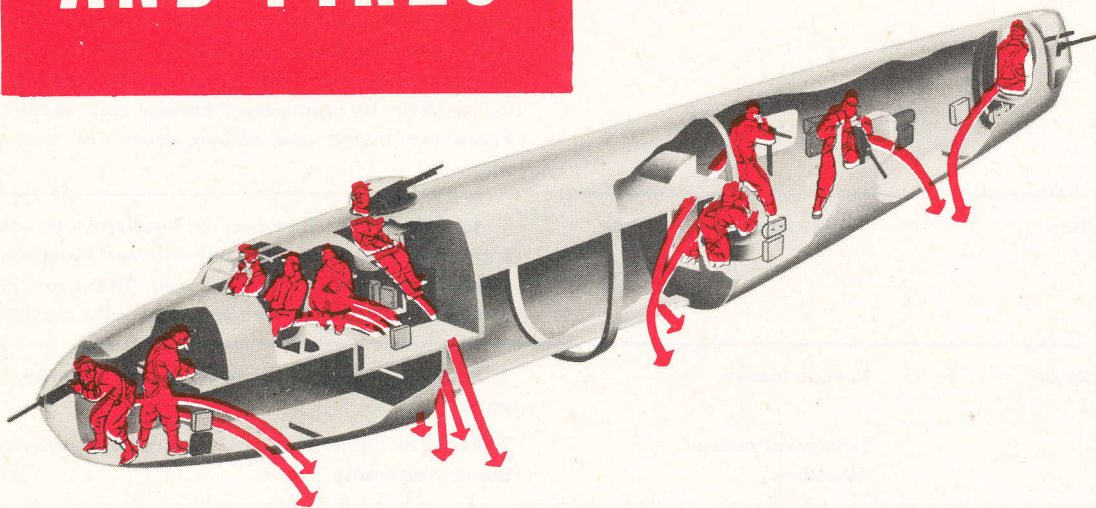

BAILING OUT OF THE B-24

It is the responsibility of the airplane commander to make certain on every flight:

1. That a parachute is available and satisfactorily fitted for each person making the flight.

2. That the parachute is conveniently located at the normal position of the person making the flight and that he knows its location, how to put it on, how and where to leave the airplane, how to open the chute and how to land and collapse the chute. (See P.I.F.)

3. That a life vest is worn under the chute harness on all over-water flights and that the crew knows the location, how to attach and how to use the individual seat-type life raft.

4. That all persons aboard know the bailout signals and the bailout procedure to be followed.

The easiest and most effective way to carry out this responsibility is to appoint a parachute officer (usually the engineer) who will make a special study of equipment, its use, approved bailout signals, and the proper method of leaving the airplane. He will assist in conducting bailout drill once each week on the ground until the entire crew is proficient, and as often thereafter as necessary to keep the crew conscious of the proper care and wearing of equipment.

Such drill only takes a few minutes at the conclusion of a practice mission.

When to Bail Out

In all cases it is the positive responsibility of the airplane commander to decide when a bail-out emergency exists. Never shirk your responsibility by putting it up to the crew. In case of fire, fuel exhaustion, mid-air collision, weather which makes a landing dangerous, or other hazardous circumstances only you, the airplane commander, can judge the extent of the danger and whether or not the crew should bail out.

Radio Your Position

The instant you suspect an emergency is developing, get your position from the navigator and have the radio operator broadcast your position and your difficulty. This may save hours or even days for rescue parties searching for you.

Bailout Signals

(Check to be sure all crew members can hear the alarm bell in flight.)

Prepare to Bail Out: Three short rings on the alarm bell. Also warn the crew by interphone and obtain acknowledgment from each crew member.

Bail Out of the Airplane: One long sustained ring.

Don't Bail Out: If you have given the signal "Prepare to bail out," don't hit the bell again or the boys will all leave. If you want to call off the emergency, send the engineer to do it or notify crew members by interphone. Where pilots have used a series of short rings to call off the emergency, half the crew have in some cases hit the silk.

Bailout Procedure

1. At the signal "Prepare to bail out," all the crew will acknowledge by interphone and make immediate preparations to leave the ship, checking parachute snaps and attaching the quick attachable-type chute if so equipped.

2. Pilot or bombardier (at pilot's direction) will open the bomb bay doors and jettison bombs to provide clearance for jumping; navi-

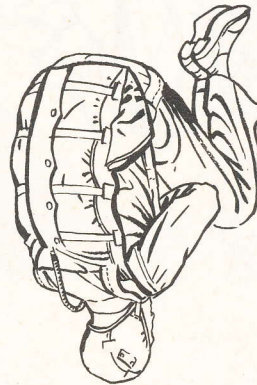

Leaving Through The Bomb Bay



Leaving Through The Nosewheel Hatch

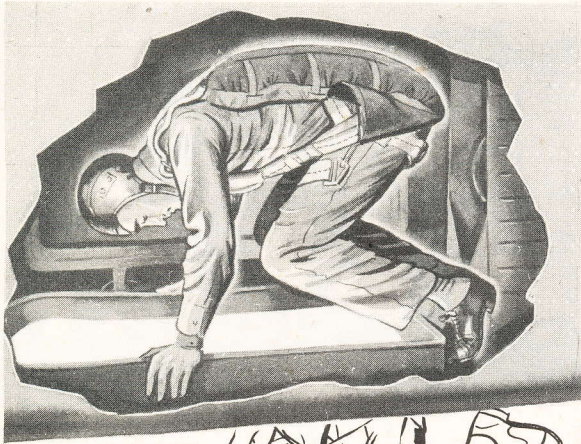

Leaving
Through
Belly Hatch



Legs Together
And Straight
When Clear
Of The Ship

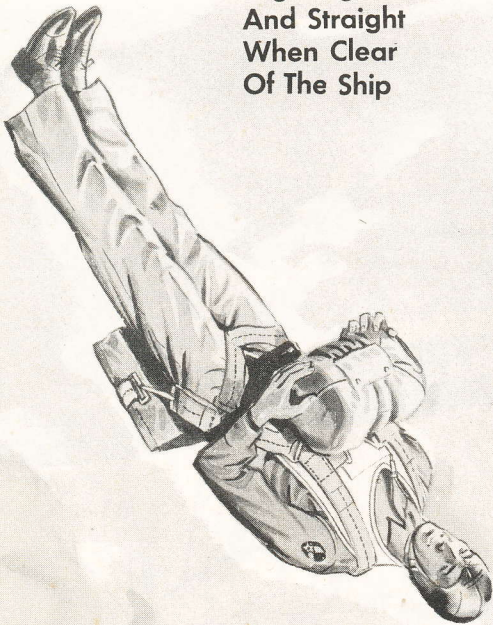

gator will open the nosewheel hatch by pulling down on the 2 red handles at Station 1.0 on the cross-member under navigator's table; tail gunner opens belly hatch. These are the 3 best bailout exits.

3. Crew should check each other's equipment to be sure it is properly fastened and attached.

4. Pilot slows airplane down to 150 mph (to 140 mph with 20° of flaps) before giving bailout signal.

5. Exits for bailout:

a. Navigator and bombardier (nose turret gunner) leave through the nosewheel hatch one after the other, facing front of ship, crouching near opening with hands on each side and rolling out headfirst.

b. Tail gunner and left waist gunner exit through belly hatch from a crouching position facing the direction of flight.

c. Ball turret gunner and right waist gunner leave through rear bomb bay; flight engineer, radio operator, copilot, and pilot also leave through the bomb bays, crouching on the catwalk facing the direction of flight.

Warning: It is extremely important in all cases to face the front of a B-24 and roll out headfirst. The airplane is traveling fast, and if you jump toward the rear there is danger of being slapped up against the airplane. If you jump feet first, the wind can catch your legs and bang your head on the edge of the hatch.

6. Don't pull the ripcord until you have straightened your legs and are well clear of the airplane, unless bailing out at a low altitude. See P.I.F. for instructions on how to fall and how to land under various circumstances.

DITCHING THE B-24

Ditching drill is the responsibility of the pilot. Duties should be studied, altered if necessary to agree with any modifications, memorized, and practiced until each crew member performs instinctively.

The moment a ditching emergency arises the pilot gives the signal for crew to take ditching positions, the altitude, and the approximate number of minutes before impact. This should be acknowledged by the crew in this order: copilot, navigator, bombardier, nose gunner,* flight engineer, radio operator, right waist gunner, left waist gunner, belly gunner, and tail gunner, with the words, "Copilot ditching, navigator ditching," etc.

Alarm Bell Ditching Signals:

1. Crew to ditching positions—6 short rings.
2. Brace for ditching—1 long ring just before impact.

Procedure

Immediately, all crew members should remove ties and loosen shirt collars and remove oxygen masks unless above 12,000 feet, in which case oxygen continues to be used until notification by the pilot.

All crew members wearing winter flying boots should remove them, but remove no other clothing. Then each crew member performs his specific duties. Have life vests on but do not inflate them before exit from airplane.

Upon warning to ditch, crew members will remove parachutes and parachute harness.

*Ten-man crew would have only one waist gunner if it has a nose gunner. All positions are mentioned as a guide. Each airplane commander will have to adapt procedures to his particular needs and equipment.

Duties Before Landing on Water

Pilot: After giving the warning he remains in the normal flight position for ditching. Fastens safety belt and shoulder harness but unfastens parachute straps. Shortly before impact, he gives a long ring on the alarm bell to notify the crew to brace for ditching.

Copilot: Remains in normal flight position. Unfastens parachute straps and fastens safety belt and shoulder harness. Assists pilot as necessary.

Navigator: Calculates position, course, speed, and estimated position of ditching and gives information to radio operator. Destroys secret papers. Gathers maps, compass, and celestial equipment. Goes to flight deck and takes ditching position.

Bombardier: Jettisons bombs and closes bomb doors. Destroys bombsight. Goes to rear compartment, checks position of others and takes ditching position.

Nose Gunner: Jettisons ammunition, locks nose turret in forward position, and goes to ditching position.

Flight Engineer: Turns guns aft. Shoots out or jettisons ammunition. Avoid getting shell cases jammed in the bomb doors. Opens and removes top hatch and jettisons it and loose equipment through the bomb bay and checks to see that it is closed. Closes floor door and rear door to flight deck after navigator comes up. Takes ditching position.

Radio Operator: Turns IFF to distress, switches on liaison transmitter (turned to MF DF frequency) sends SOS, position, and call sign continuously. On order from the pilot he clamps down key, hinges up radio table and takes ditching position.

Left Waist Gunner: Opens left waist window and leaves it open, jettisons left waist gun, ammunition and all loose equipment, preferably through the belly hatch to avoid damaging tail surfaces. Takes ditching position.

Right Waist Gunner: Opens right waist window and leaves it open. Jettisons right waist gun, ammunition and loose equipment, preferably through the belly hatch to avoid damaging tail surfaces. Goes to ditching position and remains on interphone.

RESTRICTED

Belly Gunner: Retracts ball turret and jettisons ammunition, preferably through belly hatch if time permits. Takes ditching position.

Tail Gunner: Lines up turret directly aft and locks. Comes out of tail, helps jettison ammunition and check belly hatch firmly closed. Takes ditching position.

A crew member and an alternate will be designated by the pilot before flight to take the emergency radio transmitter and all other emergency equipment to the radio room before ditching and will be responsible for getting this equipment to the life raft.

Warning: If time permits, waist windows should be removed and jettisoned through the belly hatch to avoid danger of their closing and jamming shut on impact. It is most important that all bottom hatches be closed and that the top hatch and waist windows be open.

Ditching Positions

It is impossible to specify ditching positions which will apply to every B-24 crew as location of equipment in the airplane will vary as well as crew composition. Each pilot with the help of the following information should assign definite braced positions for each of his crew members which will apply to the airplane he is flying. Crew members should use cushions and parachutes to help cushion the shock of impact and to protect the head from flying debris.

The command deck which is located above the bomb bay has proven itself the best possible ditching station in the airplane. As many crew members as possible should take up ditching positions at this station. Your airplane may have one of the two types of ditching belts on the command deck:

1. A single belt to be mounted across the fuselage with crew positions as follows:

a. Five men seated in belt facing aft, hands behind head.

b. Two additional men seated in front of the five men braced against their legs, facing aft, hands behind head (the belt is stressed for seven men).

2. A set of three short belts in tandem with crew positions as follows:

a. One man in the forward belt facing aft,

hands behind head.

b. Two men in the middle belt facing aft, hands behind head.

c. Two men in rear belt facing aft, hands behind head.

3. If your airplane is not equipped with a ditching belt, crew members will lie down, back to the floor, feet in direction of flight with knees flexed or sit facing aft, back braced against a bulkhead or another man's legs. The best exit is the hatch above command deck but waist windows may be used as alternate exit.

On the flight deck the pilot and copilot will ditch in their seats with safety belt and harness fastened. Possible ditching positions for crew not able to ditch on the command deck are as follows:

a. Standing behind pilot's seat with back braced against armor plate or canvas bulkhead, hands braced against sill of open hatch (two men can brace here side by side if necessary).

b. Standing behind copilot's seat back braced against armor plate or canvas bulkhead, hands braced against ceiling.

Approved ditching positions have been published showing men sitting on the floor of the flight deck. However, subsequent reports indicate that a standing position is preferable to avoid injury from the top turret which often comes down on impact. Exits on the flight deck are top hatch and pilot's and copilot's windows.

4. The waist is the least desirable ditching station and should only be used if the command deck is not available. If it becomes necessary to use the waist the following positions are recommended:

a. Braced against ditching belts if provided.

b. The linked arm position.

First man; seated on left side of waist, facing forward, feet against turret step, knees slightly flexed.

Second man; on right side of first man, same posture.

Third man; seated facing the left window behind the first man, feet against the fuselage, knees bent.

Fourth man; on the left side of the third

man, same posture.

Fifth man; seated facing the right window behind the second man, feet braced against the fuselage, knees bent.

Sixth man; on right side of the fifth man, same posture. All six men link arms.

c. The strength of the positioning is in leg bracing and arm linking. This can only be learned in ditching drill.

d. The position loses strength as the numbers are reduced but is considered efficient down to four men.

Approach and Touchdown

Pilot determines direction of approach well in advance. Touchdown parallel to lines of crests and troughs in winds up to 35 mph. Ditch into wind only if wind is over 35 mph or if there are no swells. Use flaps in proportion to power available to obtain minimum safe forward speed with minimum rate of descent. In every case try to ditch while power is still available. Touchdown in a normal landing attitude. Severe decelerations and several impacts may be expected, so warn your crew not to move until the airplane has come to rest.

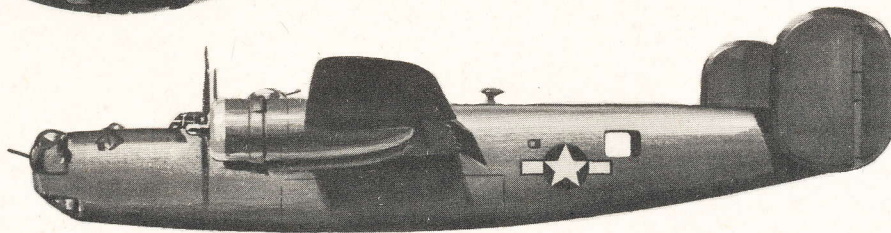
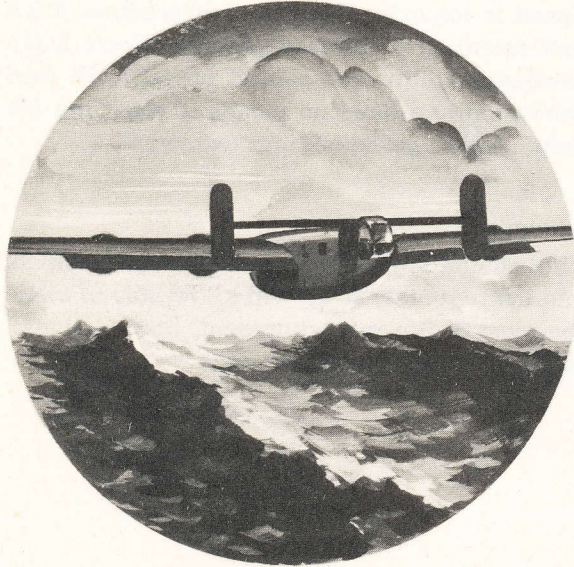

HOW TO DETERMINE WIND SPEED

A few white crests 10 to 20 mph

Foam streaks on water 30 to 40 mph

Many white crests 20 to 30 mph

Spray from crests 40 to 50 mph

RESTRICTED

Procedure After Landing

When the airplane has come to rest, engineer will pull releases on life rafts. Exits will be made as follows:

Pilot: exits through flight deck hatch, goes to left life raft.

Copilot: exits through flight deck hatch, goes to right life raft.

Navigator: exits through flight deck hatch, goes to left life raft.

Engineer: exits through flight deck hatch, goes to right life raft.

Radio Operator: Exits through flight deck hatch, goes to left life raft.

Right Waist Gunner: exits through rear hatch, goes to right life raft.

Belly Gunner: exits through rear hatch, goes to left life raft.

Bombardier: exits through rear hatch, goes to right life raft.

Left Waist Gunner: exits through rear hatch, goes to left life raft.

Tail Gunner: exits through rear hatch, goes to left life raft.

Pilot and copilot will take command each of his life raft, call roll, and check survival equipment if time permits before life rafts are cut loose from the airplane.

Note: If time and circumstances permit, take out the frequency meter and be sure to keep it dry. By attaching antenna from the Gibson Girl emergency radio to frequency meter, it can be operated as an efficient receiver to provide 2-way communication for several hours.

The Time Element

Speed is important, but so is procedure. Give first attention to injured persons. Don't leave necessary equipment behind or you will face starvation and have no means of signaling for help. Drill to get maximum teamwork.

Survival

Pilot should study P.I.F. and survival booklets and instruct crew so all will know how to make the most of life raft equipment, how to signal, and how to survive on the sea.

FIRES

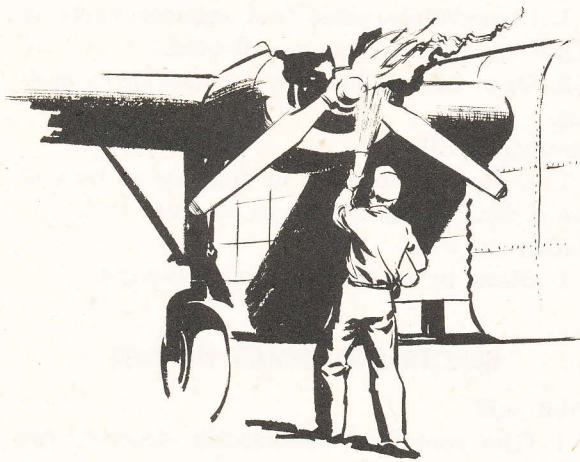

ENGINE FIRE ON GROUND

If fire occurs as engine is starting, keep engine running in an effort to blow out fire, or to suck fire into the induction system. If fire persists, or engine does not start:

Pilot will:

1. Give command "Extinguish fire in No. . . . engine."
2. Place throttle in full open position.
3. Put mixture controls in "IDLE CUT-OFF."

Copilot will:

1. Turn off fuel booster pump.
2. Turn off all engine ignition switches to protect ground personnel.
3. Place carbon dioxide (CO₂) selector valve in position for engine affected.
4. Pull fire extinguisher release handle if fireman standing by cannot control fire.
5. Pull release handle, opening remaining CO₂ bottle, if fire persists.

Engineer will:

1. Turn off fuel selector valve of affected engine.
2. Obtain CO₂ bottle from flight deck and assist fireman standing by for starting engines.

Fireman will:

1. Direct CO₂ at base of fire. When fire in accessory compartment resists other means of

control, open the starter access door and direct CO₂ nozzle toward base of flame, if possible.

Do not risk personal injury by attacking fire before propellers are stopped or by attacking fire from top of wing or nacelle; heat and flame rise.

Radioman will:

1. Stand by to aid in determining source of trouble and correcting it.

ELECTRICAL FIRE ON GROUND

Pilot will:

1. Give command "Extinguish electrical fire in . . . (location)."
2. Stop engines by placing mixture controls in "IDLE CUT-OFF."

Copilot will:

1. Place battery and main line switch in "OFF" position.
2. Turn off fuel booster pump.

Engineer will:

1. Determine that all sources of electrical power are off, including generators, auxiliary power unit or battery cart.
2. Turn valve off on sight fuel gauges.
3. Proceed to scene of fire with CO₂ bottle from flight deck and direct same at base of fire.

Radioman will:

1. Stand by to aid in determining source of trouble and correcting it.

Note: If fire persists, copilot will leave airplane to summon outside aid.

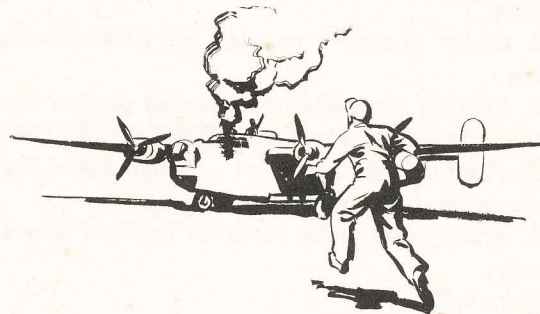

OTHER FIRES ON GROUND

Pilot will:

1. Give command "Extinguish fire in . . . (location)."
2. Stop engines by placing mixture controls in "IDLE CUT-OFF."

RESTRICTED

Copilot will:

1. Turn booster pumps off.
2. Turn main line switch off.
3. Proceed to scene of fire with CO₂ bottle from flight deck and direct same at base of fire.

Engineer will:

1. Turn fuel selector valves and fuel sight gauge valve off.
2. Obtain second CO₂ bottle from rear of airplane and aid copilot in extinguishing fire.

Radioman will:

1. Contact local control tower and request aid of fire truck, upon pilot's orders.
2. Go to scene of fire to assist in moving cargo or rendering other aid.

Note: If fire persists, copilot will leave airplane to summon outside aid.

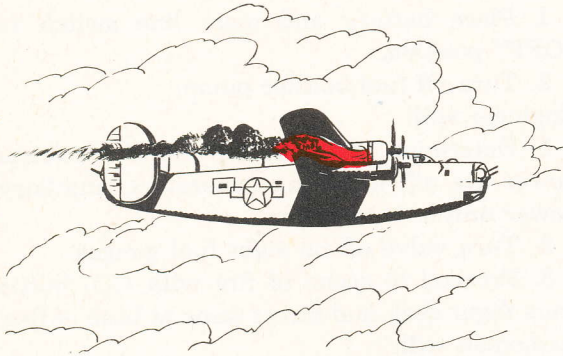

ENGINE FIRE IN AIR

Pilot will:

1. Give command "Extinguish fire in No. . . . engine."
2. Order engineer to turn off fuel selector valve.
3. Feather propeller of affected engine and place mixture control in "IDLE CUT-OFF" when fuel in lines has been exhausted and fuel pressure has dropped to zero.
4. Warn crew to be ready to bail out if necessary.

Copilot will:

1. Open cowl flaps and check booster pump in "OFF" position.
2. Place selector valve of engine fire extinguisher (panel on flight deck to right of copilot's seat) to position for engine affected (if CO₂ system is aboard). Other selector valve in "OFF" position.

3. Pull the CO₂ release valve handle of one bottle.

4. Pull second release handle, opening remaining CO₂ bottle, if fire persists.

Engineer will:

1. Immediately place fuel selector valve in "OFF" position for engine affected.
2. Open bailout hatches if condition is serious.

Navigator will:

1. Determine location of airplane at time of fire if distress signals are to be sent.

Radioman will:

1. Stand by to send distress messages.

ELECTRICAL FIRES IN AIR

Pilot will:

1. Give command "Extinguish electrical fire in . . . (location)."
2. Warn crew to be ready to bail out if necessary.

Copilot will:

1. Place battery switches in "OFF" position (not the main line).

Note: No lights or engine instruments will operate under this condition. Flashlights must be kept on hand at all times during night flights.

Engineer will:

1. Place all generator switches in "OFF" position.

2. Make certain auxiliary power unit is off.

3. Obtain CO₂ hand fire extinguisher and direct it at base of fire.

Navigator will:

1. Assist engineer at location of fire.

Radioman will:

1. Assist engineer at location of fire.

OTHER FIRES IN AIR

Pilot will:

1. Give command "Extinguish fire in . . . (location)."

2. Warn crew to be ready to bail out if necessary.

Copilot will:

1. Turn off all heater switches and valves.
2. Proceed with flight engineer to scene of

RESTRICTED

fire, obtaining if possible, second CO₂ bottle from rear of airplane.

Engineer will:

1. Proceed to scene of fire with CO₂ bottle from flight deck.

2. Open escape hatches if condition is serious enough to prepare to abandon plane.

Navigator will:

1. Determine location of aircraft at time of fire if distress signals are to be sent.

2. Act as liaison between crew members, etc.

Radioman will:

1. Stand by to send distress messages.

2. Assist engineer at scene of fire with pilot's permission.

EFFECTS OF CARBON DIOXIDE AND CARBON TETRACHLORIDE FUMES

Carbon Dioxide

Carbon dioxide (CO₂) is a non-poisonous gas and breathing it will not adversely affect a human being either at the time it is inhaled or afterwards. If the concentration of CO₂ gas is high enough, it will have a smothering effect, through the exclusion of oxygen, but the quantity of carbon dioxide gas contained in a hand extinguisher installed in aircraft is not sufficient to raise the concentration in an airplane cabin to this point.

Carbon Tetrachloride

Carbon tetrachloride is a volatile fluid, the gases of which when inhaled in large amounts act as an anesthetic, causing drowsiness, dizziness, headache, excitement, anesthesia, or sleep. One or more of these symptoms may occur. If small doses of the fumes should be breathed in over a period of time the first probable effect would be drowsiness followed by sleep or perhaps headache and nausea.

If any odor of carbon tetrachloride is detected while flying, an investigation to determine its source should be made immediately. If it is found that a fire extinguisher is leaking, it should be corrected at once or the extinguisher should be placed where it will not leak in the cabin.

Caution: Carbon tetrachloride is poisonous if taken internally. Even $\frac{1}{4}$ of a teaspoonful

may prove fatal. Symptoms of poisoning do not appear for several days after the fluid is taken into the stomach, thus giving a false sense of security. Anyone who accidentally ingests some of the fluid should report to the surgeon immediately for advice and necessary treatment.

Warning: In the presence of a flame, carbon tetrachloride produces a poisonous gas. When sprayed on a fire, carbon tetrachloride produces phosgene, one of the poisonous gases used during World War I. Inhaling even a small amount under such conditions may produce harmful effects and, if a sufficient quantity is taken into the lung, the result may be fatal. Avoid breathing the fumes when using the fluid on a fire.

FIRE EXTINGUISHER SYSTEM

Engine Fire Extinguisher CO₂

There are 2 panels on the floor outboard of the copilot. Each panel has a 2-way engine selector valve by means of which the gas can be directed to either of 2 engines, and a pull handle which opens the flow from the CO₂ cylinders. Either or both CO₂ cylinders may be used to discharge through either panel. Thus, when one cylinder is exhausted, the other cylinder may be used as a source of supply for any engine. A perforated tubing ring around the engine nacelle discharges CO₂ into the engine area.

Note: The 2 engine system bottles will empty overboard if prematurely discharged by built-up pressure. A break in the red seal in the skin on the right side of the nose is then visible **from the outside only** at Station 3.0. Make sure the safety wire on the pull handle is unbroken.

Hand Extinguishers

Inside—On aircraft up through 42-40137, one CO₂ bottle is behind the pilot and one is at Station 6.0. From 42-40138 through 42-72864, another CO₂ bottle is added at Station 1.0 above navigator's map case. From 42-72865 and on, only one CO₂ bottle is provided, located behind the pilot.

Two carbon tetrachloride hand extinguishers are available from the outside through easily recognizable red doors and from the inside through zipper coverings. One is on the left side of the fuselage near the jack pad, and the other on the right side aft of the bomb bay.

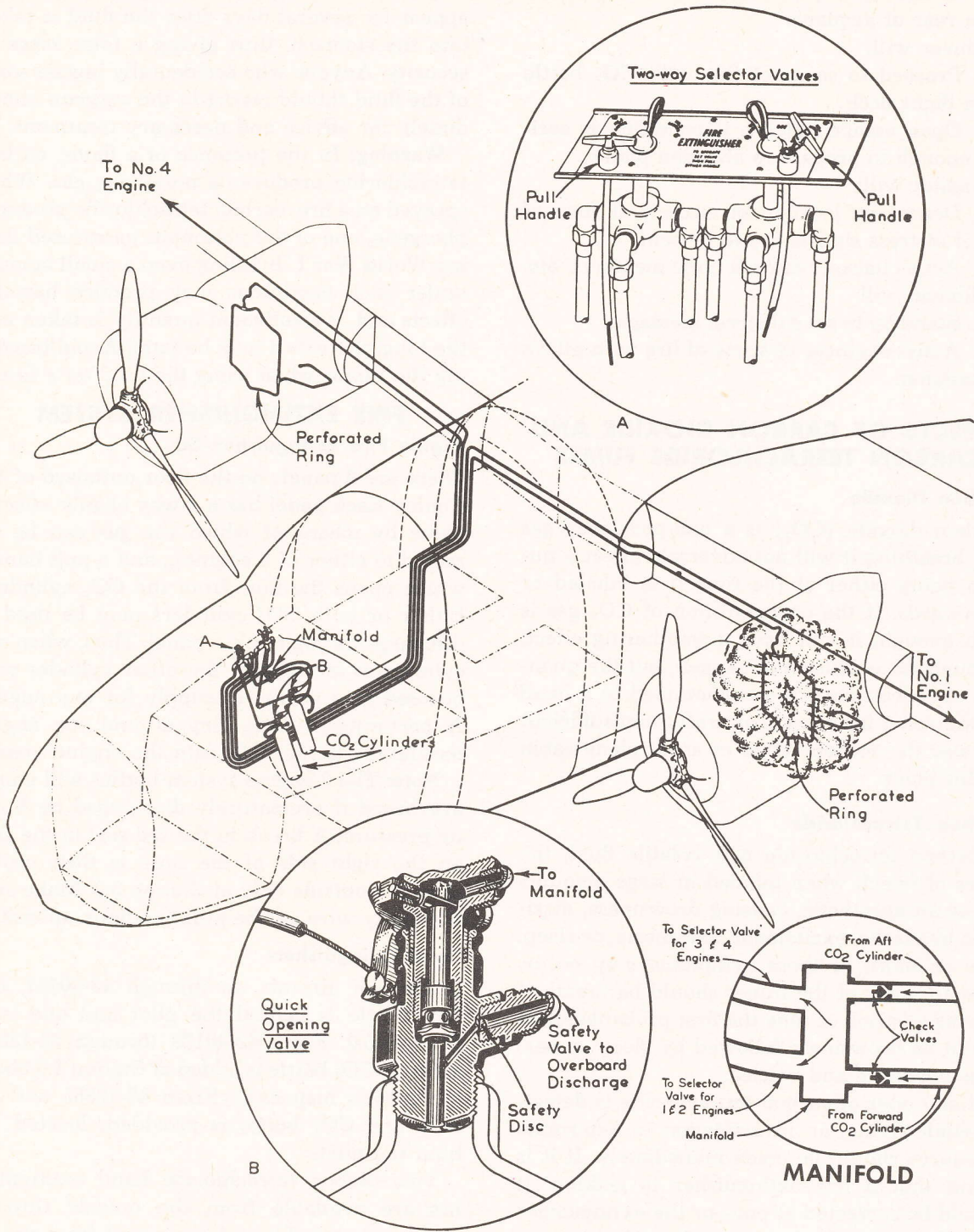

Engine Fire Extinguisher System—Prior to B-24D 42-40393

FLARES AND PYROTECHNICS

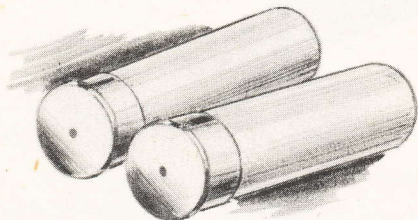

Flares

Flare ejector tube is located on the left of the center line of the airplane immediately forward of entrance door, between Stations 7.2 and 7.3.

To Load a Flare

Move operating handle downward. This rotates cam so that flare can enter tube. Insert the flare to the proper position where cam enters the slot in the side of the flare casing. Connect the flare safety to the fish line on reel.

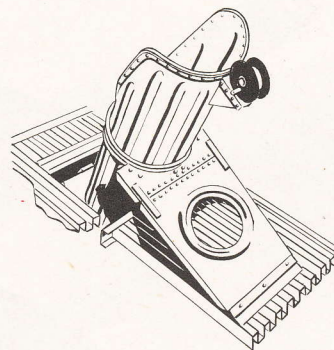

To Eject a Flare

The flare tube is fitted with 2 controls; one a toggle handle located on the inboard side of the tube which opens the door in the bottom of the fuselage uncovering the flare tube, and the second a handle located on the aft side of the flare tube which is the flare handle.

Pyrotechnics

The pyrotechnic installation located on the left side of flight deck between Stations 3.0 and 4.0 consists of:

- 1 Type M-2 signal pistol
- 1 Type A-1 portable signal container
- 9 Type M-10, M-11 signals
- 1 Type A-1 holder, pyrotechnic pistol

On B-24D aircraft Serial No. 41-23640 and on, stowage has been changed to the rear compartment, right side, between Stations 7.4 and 7.5.

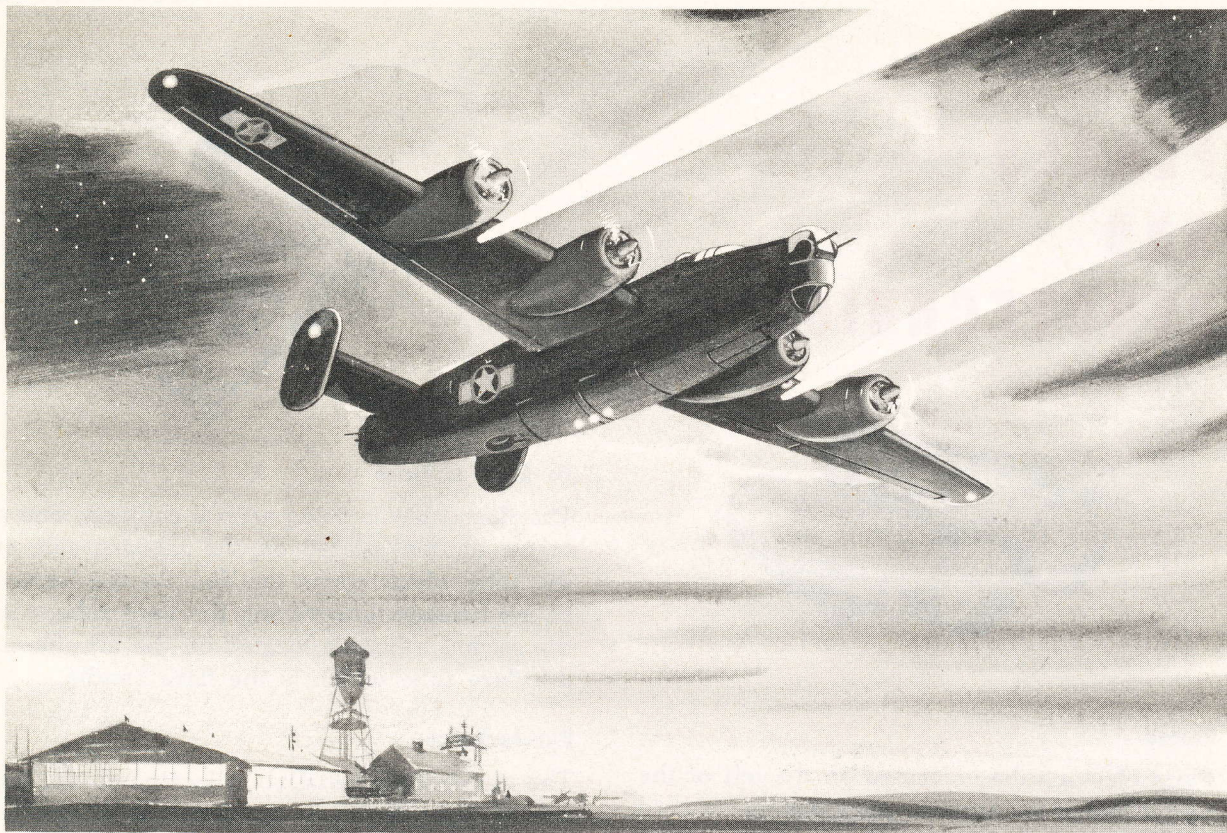

NIGHT FLYING

Night flying the B-24 is very much like day flying because in each case you fly the airplane very largely by reference to instruments. Difficulties in almost every case are traceable to failure on the part of the airplane commander to make allowances for the fact that the sun doesn't shine at night. You must faithfully perform all procedures necessary in day flying plus others made necessary by the fact that it is dark. Following is a list of practical suggestions that make night flying easier and safer.

Night Inspection

Don't neglect your inspection of the airplane and crew. Trouble at night is double trouble. Perform your exterior inspection with a flashlight and with extra care. There is a greater



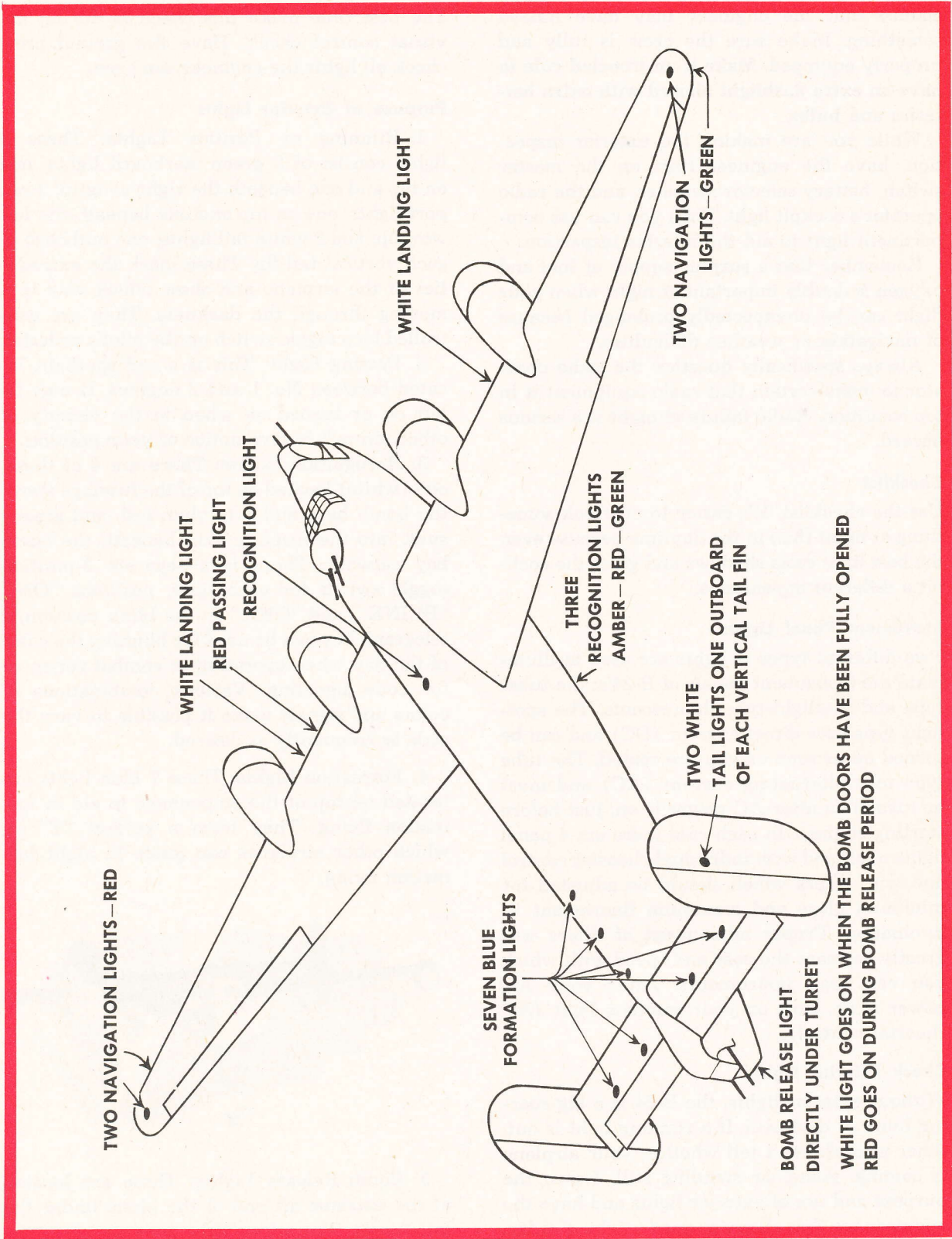

WHITE LIGHT GOES ON WHEN THE BOMB DOORS HAVE BEEN FULLY OPENED
RED GOES ON DURING BOMB RELEASE PERIOD

RESTRICTED

chance that the engineer may have missed something. Make sure the crew is fully and properly equipped. **Make it an ironclad rule to have an extra flashlight aboard with extra batteries and bulbs.**

While you are making the exterior inspection, have the engineer turn on the master switch, battery selector switches, and the radio operator's cockpit light. Then you can use compartment light to aid the interior inspection.

Remember that a surplus supply of fuel and oxygen is doubly important at night when your flight can be unexpectedly prolonged because of navigation or weather difficulties.

Always specifically question the radio operator to make certain that radio equipment is in top condition. Radio failure at night is a serious hazard.

Checklist

Use the checklist. It's easier to overlook something at night than in the daytime because even the best light casts shadows and gives the cockpit a different appearance.

Instrument Panel Lights

Two different types of lights are used to illuminate the instrument panels of B-24's: the tube-type and spotlight-type fluorescents. The spotlight type uses direct current (DC) and can be turned on as soon as you are seated. The tube type uses alternating current (AC) and must be turned on after AC power is on, just before starting engines. In each case there are 4 panel lights equipped with individual rheostat control and with filters which should be adjusted for minimum glare and maximum fluorescent illumination. Proper adjustment of filters will greatly increase the ease and speed with which you can read instruments. After your AC power is on, turn on your compass light (AC rheostat control).

Check Exterior Lights

Without exterior lights, the B-24 is a big roaring hunk of darkness. If a running light is out, other aircraft can't tell whether your airplane is coming, going, or standing still. Learn the purpose and use of exterior lights and have the engineer see that all are in good working order.

The best time make this check is during the visual control check. Have the ground crew check all lights the engineer can't see.

Purpose of Exterior Lights

1. Running or Position Lights: These 6 lights consist of 2 green starboard lights, one on top and one beneath the right wingtip; 2 red port lights, one on top and one beneath the left wingtip; and 2 white tail lights, one outboard of each vertical tail fin. These mark the extremities of the airplane and show which way it is moving through the darkness. They are controlled by a toggle switch on the pilot's pedestal.

2. Passing Light: This is a red spotlight located between No. 1 and 2 engines. It may be left on or turned on when in the vicinity of other aircraft to give notice of your position.

3. Recognition Lights: There are 4 of these, one (white) located on top of the fuselage above the bomb bays and 3 (amber, red, and green) sunk into the fuselage skin beneath the bomb bay catwalk. There is a separate 3-position toggle switch for each light, positions "ON," "BLINK," and "OFF." In the blink position, a telegraph key can be used for blinking the color of the day when operating in combat zones, or for code signaling. Various combinations of colors and signals make it possible to vary the code as frequently as desired.

4. Formation Lights: These 7 blue lights are located on top of the empennage to aid in formation flying. They form a perfect "T" on which other airplanes can guide in night formation flying.

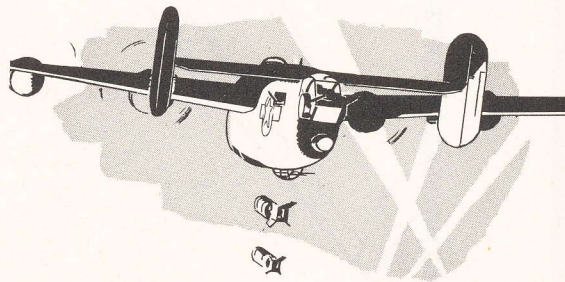

5. Bomb Release Lights: These are located at the extreme aft end of the plane under the tail turret. The white light goes on when the

bomb doors have been fully opened. The white light goes out and the red light goes on during the bomb release period; it is extinguished 5 seconds after the last bomb has dropped. This gives warning and protection to other airplanes in your formation. In training, these lights are sometimes wired to remain on all the time.

6. Landing Lights: The 2 landing lights are located just inboard of the wheel wells with separate toggle switches for each. They are extremely powerful and produce terrific heat confined in a small space. When the plane is flying, this heat is dissipated rapidly, but on the ground it can quickly burn out the bulb, especially in warmer climates. Never leave them burning for over 3 minutes when the plane is on the ground.

Taxiing at Night

1. Follow all daytime procedures with extra care. Be sure the flight indicator and directional gyro are working perfectly. You'll rely on them more than ever.

2. Turn off all inside white lights for taxiing. Use both landing lights while taxiing in close quarters but turn off one as soon as possible and then switch back and forth from one to the other every one to two minutes to avoid overheating. Make turns with the inside landing light on.

3. Post an observer with his head out the flight deck hatch. Clear congested areas with a man on each wingtip and one out in front.

Warning: Use extraordinary precautions. You can't see your wingtips and obstructions are concealed. Don't go off the runway, or ram parked aircraft.

4. If in doubt, ask the tower where to turn. It will keep you from ending up in a mudhole or on some strange main street.

5. Remember there are other aircraft around. Get radio clearance from the tower for crossing runways. If taxiing toward a landing runway, retract your landing lights to keep from blinding incoming pilots. When you get in position for run-up, turn off your landing lights to save batteries and avoid overheating.

Run-up

Your run-up is the same as in the daytime, but you have the problem of interior lighting. Be sure and have a red filter on the radio operator's light, or the white light will impair your night vision. Use a filtered flashlight to further aid your run-up check. Always make sure crew are in proper positions for takeoffs and landings and that one crew member in rear compartment is on interphone.

Takeoff

Make certain of your radio clearance to the takeoff runway and check for incoming airplanes. As you turn into position for takeoff be sure that you are lined up straight with the runway lights and that the nosewheel is straight.

Landing lights should be used or not in accordance with local requirements. However always flash both lights down the runway long enough to make certain that the way is clear. Fatal accidents have resulted from failure to do this.

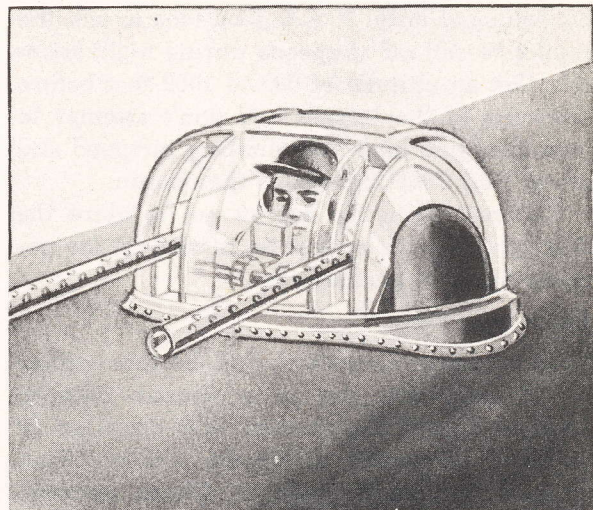

Top Turret Observer: Where possible put a man in this position during landings, takeoffs, and traffic flying to observe and report all traffic by interphone.

RESTRICTED

Stay down the runway by combining the use of the directional gyro and reference to the runway lights after you get rolling. Three instruments govern your takeoff: directional gyro, flight indicator and airspeed indicator. Be particularly careful not to hurry the airplane off the ground at night. If you have plenty of runway, get 5 to 10 mph extra flying speed (especially if heavily loaded) and let the airplane fly itself off, judging your attitude by the flight indicator. Hold to your rate of climb, your airspeed and your gyro heading. After you leave the runway it is easy to get into a turn if you don't follow your directional gyro and flight indicator. Don't lower the nose so that the miniature airplane on the flight indicator drops below the horizon bar or you will fly into the ground. Control airspeed with slight change in attitude.

Immediately after leaving the ground you'll find yourself in sudden darkness. **Fly by reference to instruments.** Flying half contact and half instruments at night is fatal, especially on takeoffs over dark areas. Pilot should be entirely on instruments but copilot can remain in outside contact when not checking instruments, his principal duty. It is a good idea to ask the copilot to call off airspeeds during night takeoffs. Get an altitude of 500 to 1000 feet before referring to the terrain and don't attempt to turn until you have full climbing airspeed and are at least 1000 feet above the terrain.

Caution: Warn the copilot not to glare the flashlight in your eyes if he is using it for periodic check of instruments.

Alert Your Crew

Spotting other aircraft should be the regular job of your crew just as in combat. Require them to report the position and direction of travel of all aircraft within the zone of vision of their respective positions. Check immediately with the responsible crew member if an airplane appears unreported. Make your crew feel you are relying on them for specific duties.

Don't Chase Lights

It is difficult to tell whether a light is in the air or on the ground, whether it is moving or standing still. Don't chase lights. You may find

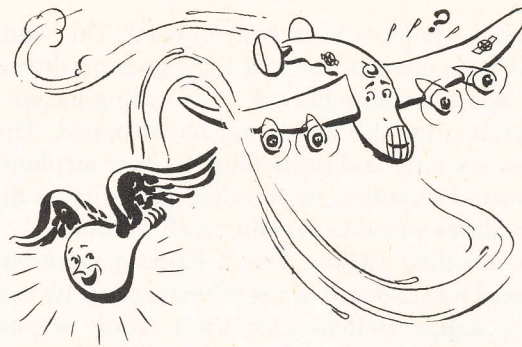

you have unintentionally dropped a wing to follow a light. The best procedure is to closely follow your gyro heading, check the attitude of your airplane and line up the light with a reference point on the airplane. Then you can soon tell whether it is moving, and in what direction in relation to your line of flight.

Cruising tips

1. Synchronize propellers with a flashlight or by the reflection from landing lights.
2. Require the entire crew to use oxygen from the ground up for all flights above 10,000 feet.
3. Require the copilot to check all instruments regularly—with a filtered flashlight if difficult to read.
4. Restrict banks to standard needle-width turns.
5. Keep track of where you are and require a record to be kept of the time flown on each heading.
6. Keep an hourly log of fuel consumption without fail.
7. Require the radio operator to send in position reports every 30 minutes.
8. Know the terrain over which you are flying, elevations, location of airfields, location of airways, etc.
9. Don't unnecessarily increase the intensity of cockpit lights when flying instruments at night. This impairs night vision for at least 30 minutes after lights are turned down.
10. Turbulence: Reduce airspeed to 150 mph to reduce strains on the aircraft.

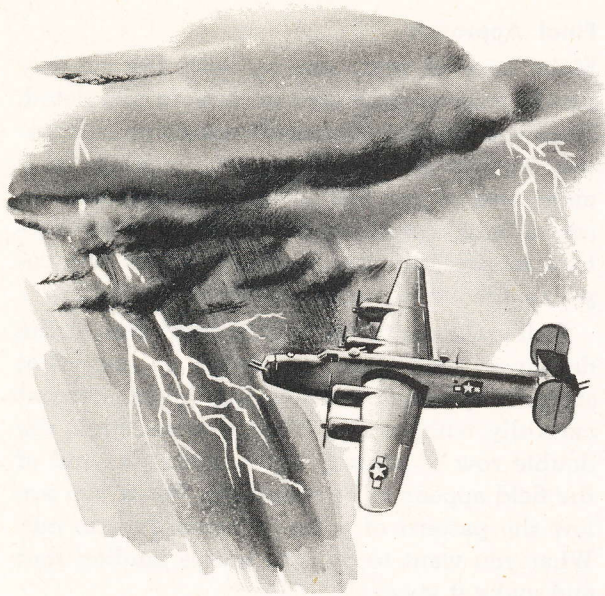

11. Remember that a flash of lightning can cause temporary blindness for 10 minutes or more. Where there are repeated flashes of lightning, it may be necessary to turn on all cockpit lights as bright as possible and go entirely on instruments. If static gets bad in the headphones, turn volume low or put earphones up off ears.

Radio Failure

In case of complete failure of the radio, attract the attention of the tower by flying over the field 500 feet above traffic and repeatedly flashing the landing lights or signaling with the recognition lights or the Aldis lamp; obtain clearance to enter traffic by light-gun signals from the tower.

Night Landings

Always know the altimeter setting, exactly what traffic pattern is used, and the altitude before takeoff. At strange fields notify the tower of your presence early. One of the main jobs of the tower is to tell you the number and location of other aircraft in the area. Remember that day and night traffic altitudes differ at many fields, usually being higher at night. Give the tower a chance to warn you of traffic conditions. It may be necessary to hold you in a zone until other operations are completed. Ask the heading of the landing runway, the wind, altim-

eter setting and the length of the landing runway so you know exactly what to prepare for and to expect. Plan ahead.

As soon as you are called in, proceed at once to join traffic. Tell the tower where you are, and call as you enter the downwind leg, base leg, and final approach. The more information the tower has about you, the more it can do to guide you safely in traffic.

Execute procedures just as in the daytime. Flying your gyro heading and timing your distance out from the end of the runway on the downwind leg is doubly important. Remember that a high wind will drift you out considerably on a long base leg.

Turning on Final Approach

One of the key points in night flying is judging when to turn on final approach. Your turn will carry you about $\frac{3}{4}$ of a mile closer to a projection of the landing runway. As you come along

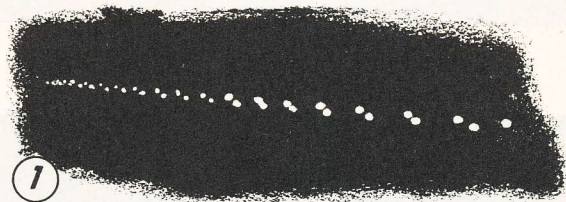

RUNWAY LIGHTS APPEAR TO BE IN SINGLE ROW AT COMPLETION OF TURN ON TO BASE LEG

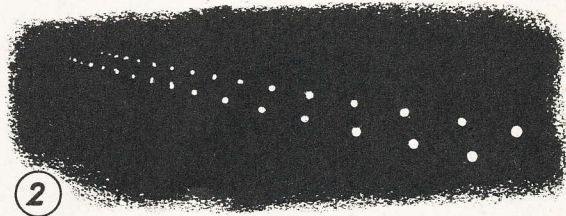

START TURN ON FINAL APPROACH AS TWO ROWS OF LIGHTS START TO SEPARATE

the base leg, the 2 rows of runway lights will look like a single row. Start your turn at the moment the 2 rows of lights start to separate. Complete your roll-out from your standard-rate turn just as the rows of runway lights are squared away at full width. Don't lose altitude in your turn. The most common error is not to lead the turn enough, find that you are going

RESTRICTED

too far past the straight line with the runway, and then to steepen the turn. **Don't make this mistake.** Turns steeper than standard rate should not be made at night in a B-24, especially at reduced speeds used in the traffic pattern.

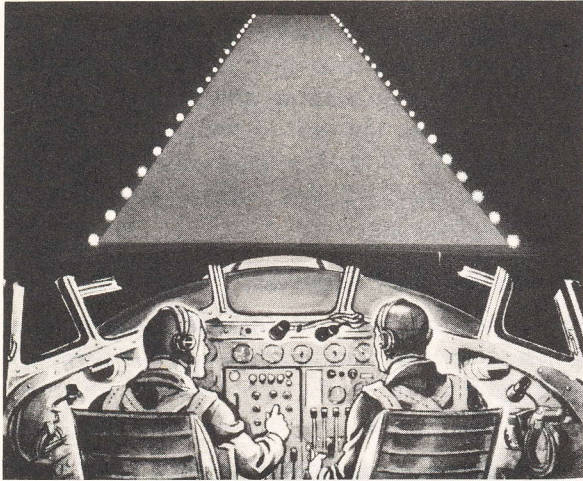

TOO LOW—LIGHT PATTERN APPEARS FLAT

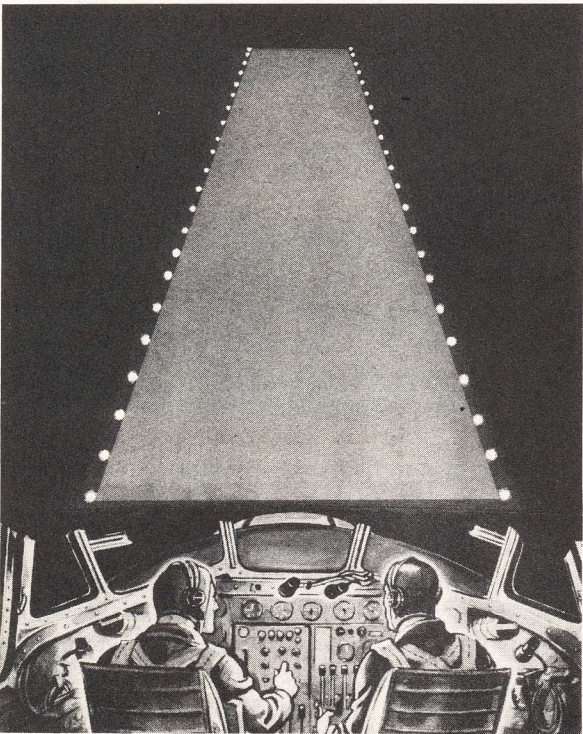

TOO HIGH—LIGHT PATTERN APPEARS TO RUN UPHILL

Final Approach

Make sure of your line-up with the runway just as soon as your turn on final is completed. Then you are free to concentrate all your attention on your descent. Turn your landing lights on as soon as you roll out on final approach. In case a hazed condition blinds you, it is satisfactory to use only the landing light on the copilot's side until you are closer to the field.

Pull up closer to the field at night than in the daytime. You want to make a somewhat steeper approach, controlling your descent carefully with power. When you are high, the double row of runway lights at the far end of the field appear to be raised up. When you are low the pattern of runway lights flattens out. What you want to do is to pick a landing spot and make it good.

Making Good Your Point

The green lights at the approach end of the runway are the point you want to make good. As you start your descent, line up these lights with a reference point on the outline of the nose or in your windshield. If the green lights move higher, you are undershooting; if they move below your reference line as you descend, you are overshooting. Make adjustments in power accordingly. As in a day landing, maintain a descending airspeed of 125 mph and a descent rate of about 500 feet a minute. Keep your copilot on his job. Have him call off both airspeed and altitude.

How to Use Your Eyes

Remember the principles of night vision. Don't look at things directly. Keep your eyes shifting from the general pattern of lights, to the point you want to make good, to what your landing lights reveal, etc. Don't stare at the whole pattern of lights or you will think the field is closer than it actually is and you'll want to flare out too high. Don't stare down the landing lights or you'll tend to fly into the ground, leveling off late. Remember that the angle of your landing lights to the ground will change as you change the attitude of the airplane. At the beginning of your descent, they will be at a steeper angle than your descent path. As you come into your

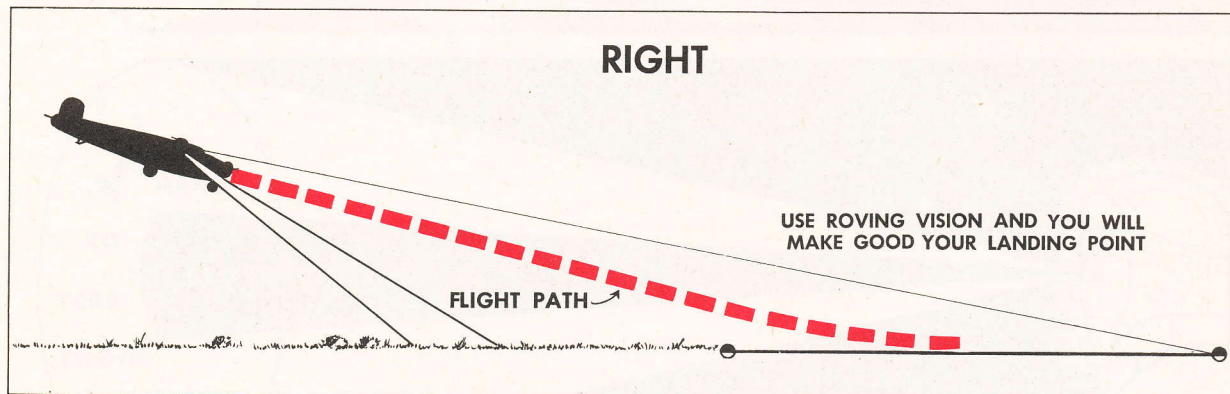
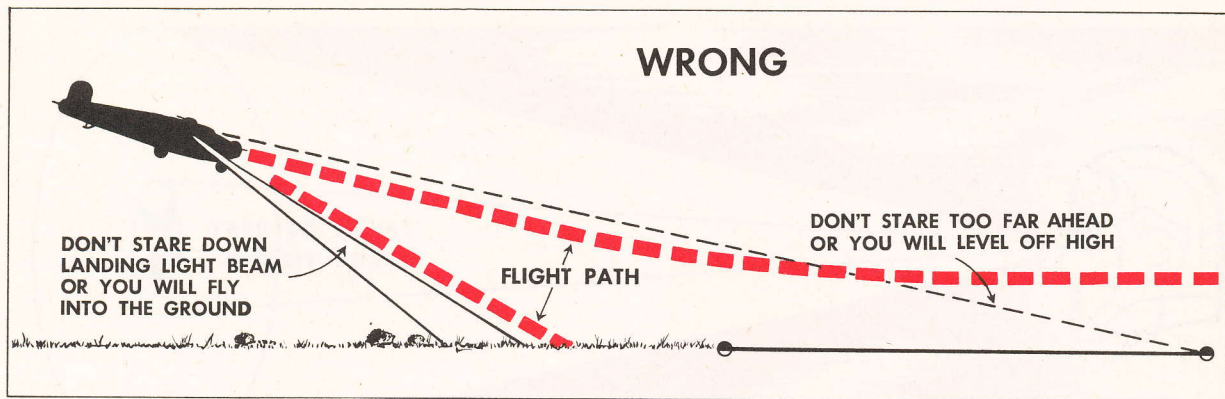

flare-out, they will make a shallower angle than your path of descent.

Watch out for red obstacle lights. These may be 50 to 100 feet above the ground and may be on water towers, or on poles with wires strung between. Don't ever get below them.

The Flare-out

If you control your descent to make good your point, it will bring you in to make contact within the first $\frac{1}{3}$ of the runway. When your lights start to pick up detail on the ground, you'll be about 100 feet up and should start your flare-out. The ground will be well illuminated and objects clearly defined. The usual tendency is to flare out too high and pull power completely off too soon. Coordinate the reduction of power with your flare-out but keep some power on to control your rate of descent and to

let you down easy. Don't pull all power off until you touch. Note tire marks and the size of runway lights to help your depth perception. You may think you are down when you're not. Amount of power will vary from 11" to 15", depending on the weight of your airplane.

Landing Roll

As soon as your wheels are on the ground, ease the nosewheel down, and test out your brakes somewhat earlier than in day landings. It is more difficult at night to judge how much runway you have left. Make sure you are going to get the airplane stopped before you run out of runway. Clear the runway at once. Don't try to taxi on your own. Ask the tower where to turn and keep moving. There may be another plane behind you that also must clear the runway quickly.

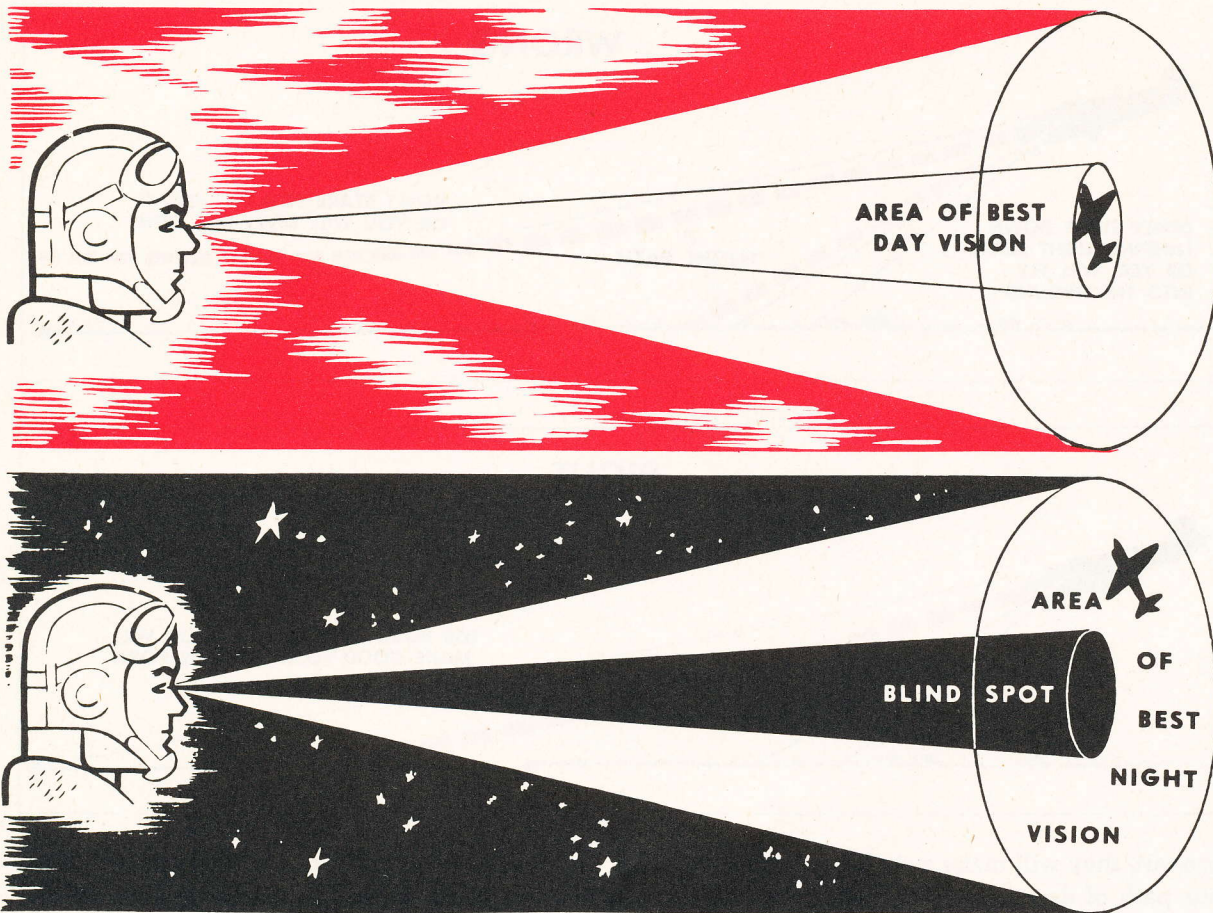

NIGHT VISION IN THE B-24

A large airplane presents a special problem in night vision. There are a lot of instruments and controls, and there is a temptation to flood the cockpit with white light while you are starting engines and running them up. There are two ways to solve this problem:

1. Use a red filter or cellophane covering over the radio operator's light and over your

night flashlights. Then your eyes will be adapting themselves to darkness during your preparations for flight.

2. Another way is for the pilot to use red adapter goggles until the cockpit lights are out for taxiing, using them again during run-up if necessary. Landing lights will not greatly impair night vision.

FORMATION FLYING

When you get into combat you will learn that your best assurance of becoming a veteran of World War II is the good, well-planned, and well-executed formation.

Formation flying is the first requisite of successful operation of heavy bombers in combat. Groups that are noted for their proficiency in formation flying are usually the groups with the lowest casualty rates. Proper formation provides controlled and concentrated firepower, maneuverability, cross-cover, and precise bombing pattern, and permits most effective fighter protection.

Heavy Bomber Formations

Formation flying in 4-engine aircraft presents greater problems than in smaller aircraft. The problems increase in almost direct proportion to the airplane's size and weight. In the B-24, relatively slower response to power and control changes requires a much higher degree of anticipation on the part of the pilot. Therefore you must allow a greater factor of safety.

Violent maneuvers are dangerous and the necessity for them is seldom encountered. Close flying becomes an added hazard; it accomplishes no purpose and is not even an indication of a good formation. Remember that it is much more difficult to maintain position when flying with proper spacing than with wings overlapping.

"Safety first" is a prerequisite of a good heavy bomber formation because of the number of lives and amount of equipment for which the pilot is responsible.

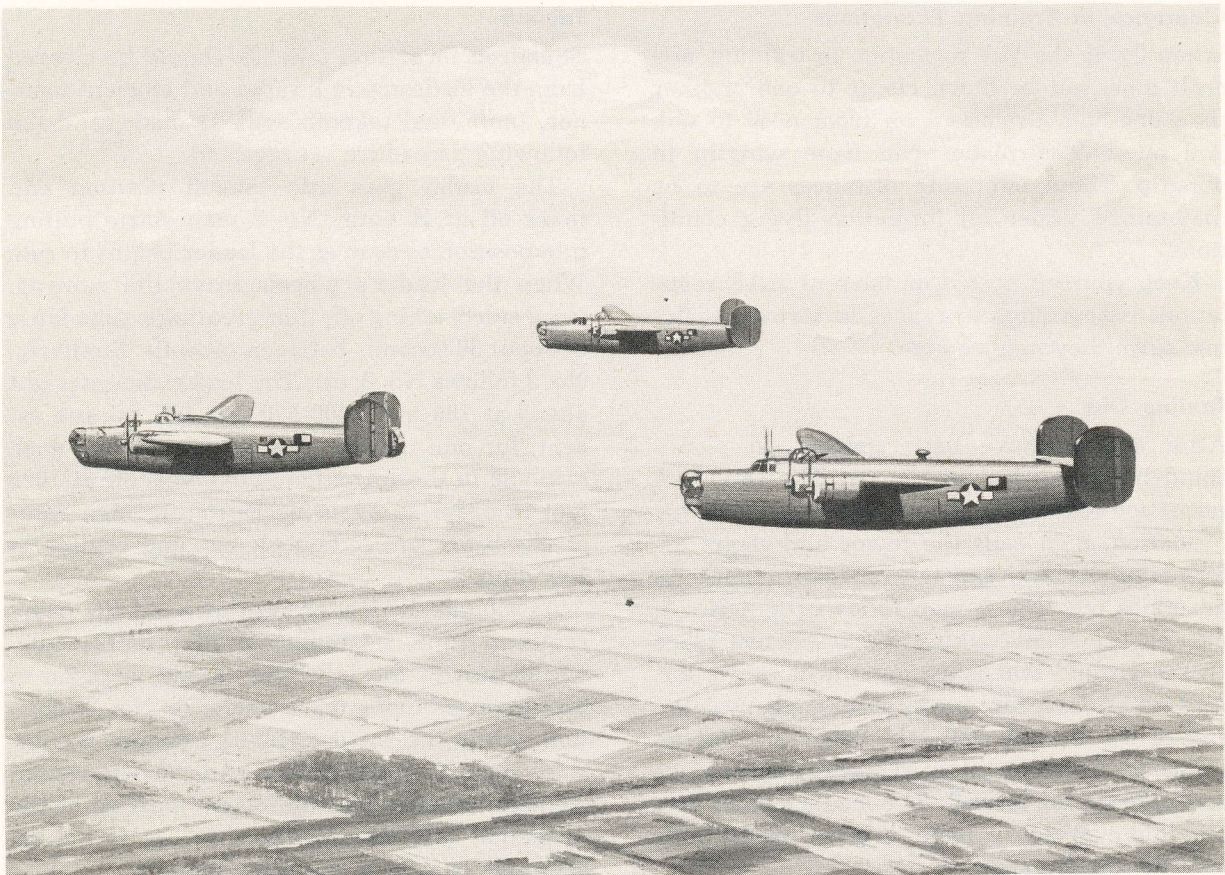

THE VEE FORMATION

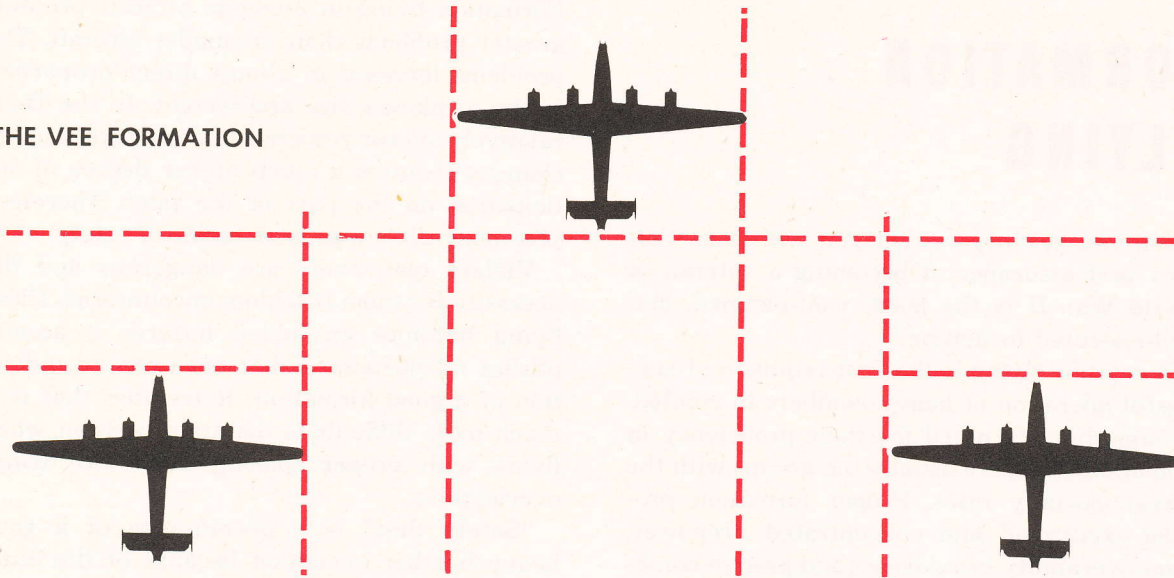
**Clearance in Training Formations**

When flying the Vee formation in training, aircraft must not be flown closer to one another than one-half airplane span from nose to tail, and one-half airplane span from wingtip to wingtip. These minimum distances are to be maintained under all formation flying conditions.

Keep yourself posted on current AAF regulations concerning clearances in formation flying, since they may change.

Taxiing Out

After engines have been started, all planes stand by on proper frequency. The squadron formation leader checks with the planes in his formation, then calls the tower and clears his formation for taxi and takeoff instructions. As he taxis out, No. 2 man follows, then No. 3, etc., each airplane taking the respective place on the ground that is assigned to it in the air. As soon as the leader parks at an angle near the end of the takeoff strip, the other aircraft do the same. At this point all planes run up engines and prepare for takeoff. The leader makes certain that everyone is ready to go before he pulls onto the takeoff strip.

Takeoff

Squadron formation takeoffs should be cleared from the airdrome in a rapid and efficient manner. Individual takeoffs will be made, and the following procedure is suggested.

The leader goes into takeoff position and takes off at H hour. No. 2 man starts pulling into position as soon as the leader begins to roll. When the leader's wheels leave the runway, No. 2 starts taking off, thus creating a time lapse of about 30 seconds between takeoffs. Similarly, No. 3 follows No. 2, etc. The leader flies straight ahead at 150 mph, 300-500 feet per minute ascent, for one minute plus 30 seconds for each airplane in the formation. He levels off at 1000 feet in order to avoid necessitating high rates of climb for succeeding planes, and cruises at 150 mph.

As soon as the leader has flown out the exact required time, he makes a 180° half-needle-width turn to the left. The second airplane in formation assumes the outside, or No. 2, position, while the third airplane assumes the inside, or No. 3, position. The leader of the second element assumes position on the outside of the formation and the airplanes in his formation assemble on him in the same manner.

FORMATION TAKEOFFS

Altitude 1,000 Ft.
Airspeed
150 MPH

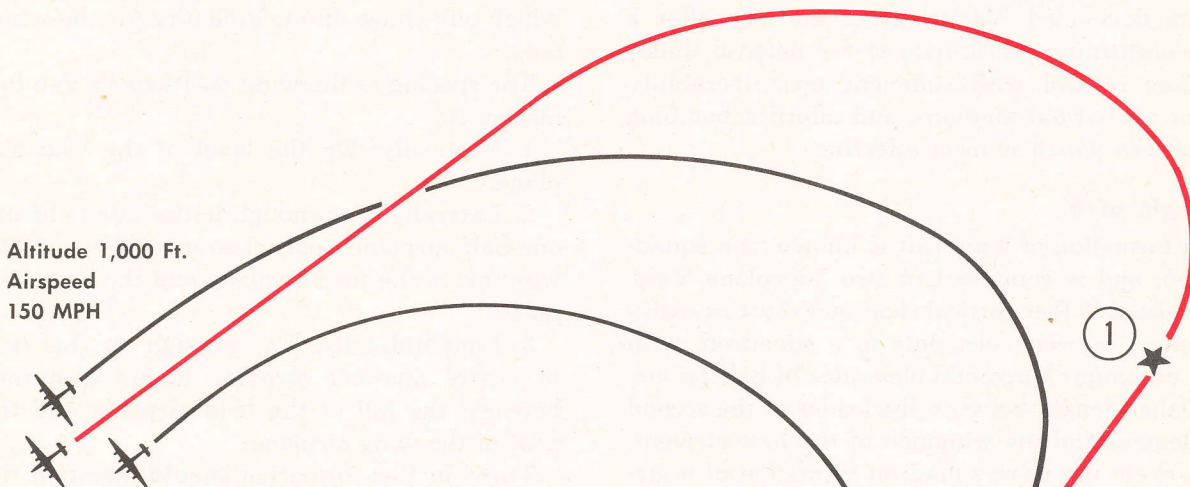

- 1 Lead airplane flies straight out for 1 minute + 30 seconds for each airplane, then makes a 180° half-needle width turn.
- 2 10 seconds after lead airplane starts to turn, the second airplane starts its turn, keeping the nose ahead of the leader, pulling into position from below and behind the leader's OUTSIDE wing.
- 3 10 seconds after the second airplane starts to turn, the third airplane starts its turn, keeping the nose ahead of the leader, pulling into position on the leader's INSIDE wing.

Climb 300-500 Ft.
per Minute

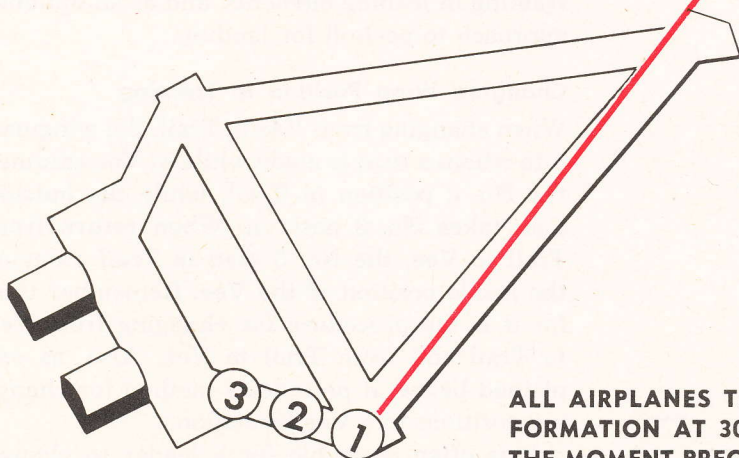

ALL AIRPLANES TAKE OFF IN THE ORDER OF JOINING FORMATION AT 30 SECOND INTERVALS. (TIMING FROM THE MOMENT PRECEDING AIRPLANE OPENS THROTTLE TO START TAKEOFF RUN)

RESTRICTED

3-Airplane Vee

The 3-airplane Vee is the standard formation and the basic one from which other formations are developed. Variations of the Vee offer a concentration of firepower for defense under close control with sufficient maneuverability for all normal missions, and afford a bombing pattern which is most effective.

Flight of 6

A formation of 6 aircraft is known as a squadron, and is composed of two 3-airplane Vees. At least 50 feet vertical clearance must be maintained between elements in a squadron, with a minimum horizontal clearance of half an airplane's length between the leader of the second element and the wingmen of the first element.

From the basic squadron formation of 6 aircraft the group, made up of 12 to 18 aircraft, is formed. With but small variations, this can be changed to the combat formations used overseas. It is the purpose of training to teach a basic formation which can be readily understood and flown by students and easily adapted to tactical use.

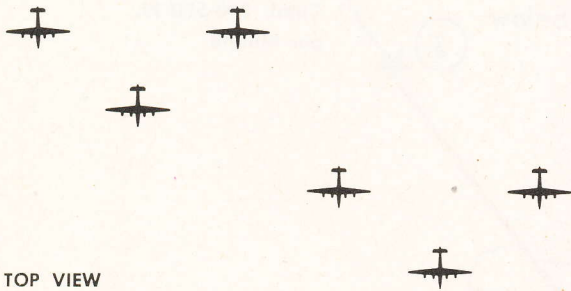

TOP VIEW

Element of Six

FRONT VIEW



Spacing of Wing Positions

It is particularly important for the leader to avoid violent maneuvers or improper positions which will cause undue difficulty for the wingmen.

The spacing of the wing positions in Vee formation is:

1. Vertically: On the level of the lead airplane.
2. Laterally: Far enough to the side to insure one-half airplane span clearance between the wingtips of the lead airplane and the wing airplane.
3. Longitudinally: Far enough to the rear to insure one-half airplane length clearance between the tail of the lead airplane and the nose of the wing airplane.

Turns in Vee formation should maintain the relative position of all airplanes in the element.

Practice Trail Formations

A formation is in trail when all airplanes are in the same line and slightly below the airplane ahead. The distance between airplanes will be such that the nose of each airplane is slightly to the rear of the tail of the airplane ahead. It is important that this distance be properly maintained, since if it becomes too great the propeller wash of the airplane ahead will cause difficulty in maintaining formation. Trail formations are to be used only when there are from 3 to 6 aircraft involved, and for purposes of changing the lead, changing wingmen, training in leading elements, and as an optional approach to peel-off for landing.

Changing Wing Position in Training

When changing from Vee to Trail, the wingman into whom a turn is made while in Vee assumes the No. 2 position in Trail, while the outside man takes No. 3 position. When return from Trail to Vee, the No. 3 man in Trail assumes the inside position of the Vee. Remember this, for it is the procedure for changing from Vee to Trail and from Trail to Vee. Also, as explained below, it provides a method for changing positions in a Vee formation.

It is often desirable for a leader to change the wing positions of his formation, i.e., to

VEE-TRAIL-VEE

NO CHANGE IN WING POSITION

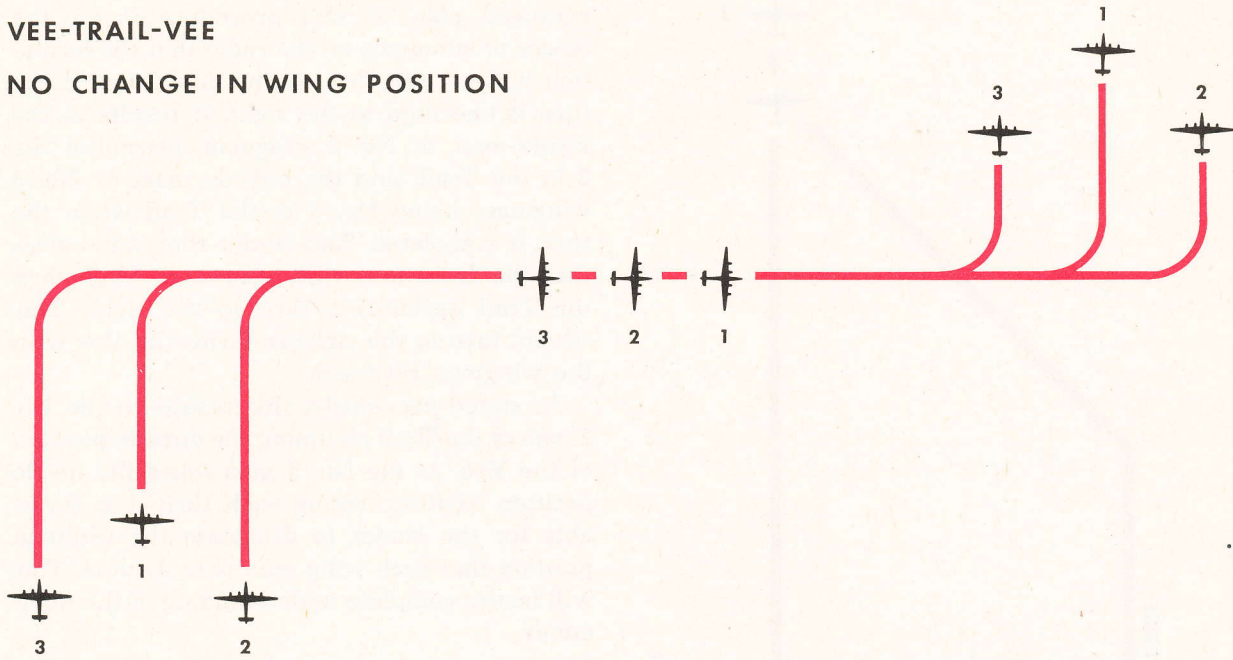

VEE-TRAIL-VEE
CHANGE WING POSITION

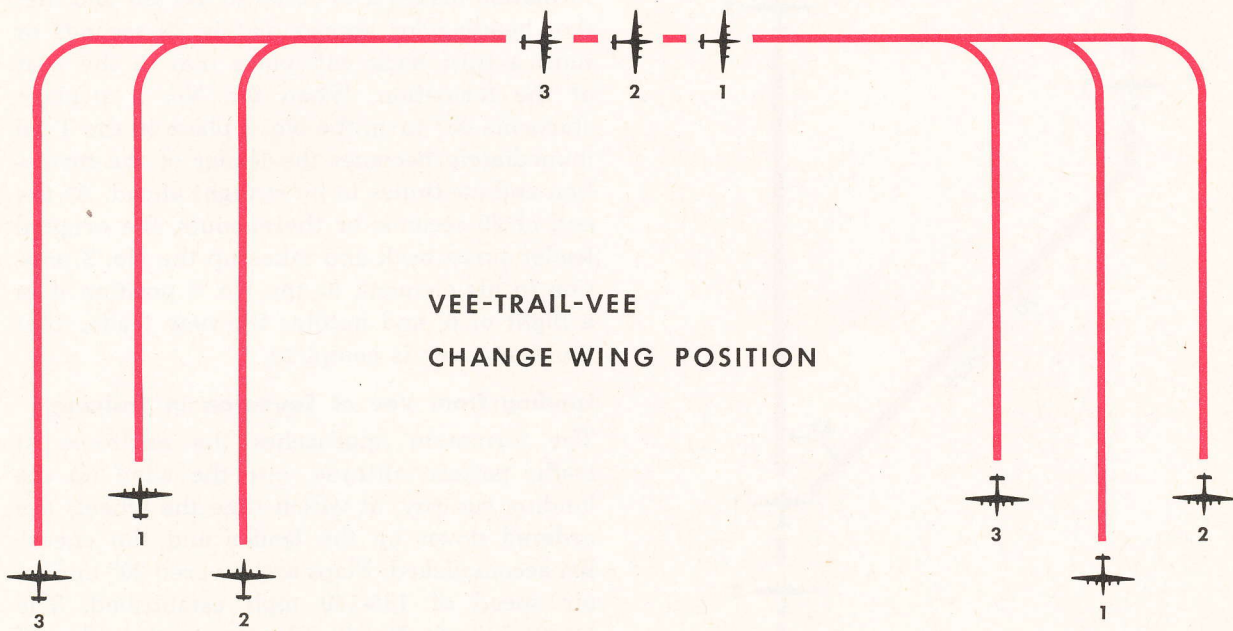

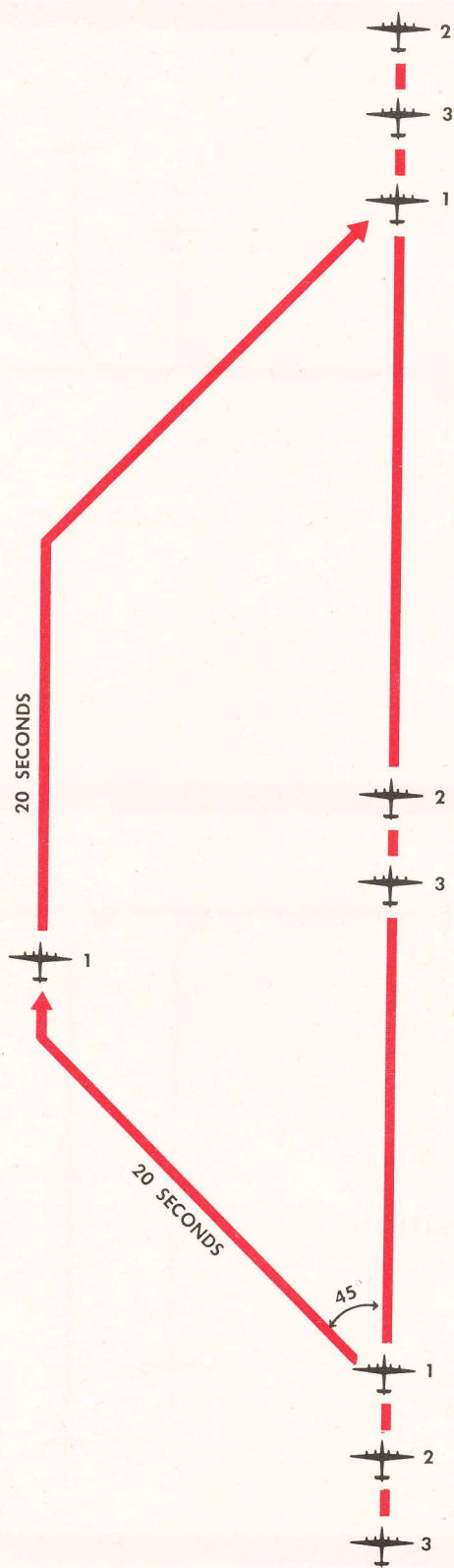

reverse the right and left positions. This maneuver offers danger of collision unless it is executed properly in accordance with a pre-arranged plan. A safe procedure is for the leader to announce on the radio that the formation will go into Trail on his first turn. If the turn is executed to the right, it results in the inside man, or No. 2 wingman, becoming No. 2 in the Trail, and the outside man, or No. 3 wingman, being No. 3 in the Trail when the turn is completed. The leader then announces that the formation will re-form in Vee when the Trail executes a turn to the right. This second turn to the right re-forms the Vee with the wingmen reversed.

As stated previously, this results in the No. 2 man of the Trail assuming the outside position of the Vee, as the No. 3 man takes the inside position. Before making each turn it is desirable for the leader to designate the ultimate position that each wing man is to assume. This will insure complete understanding of the maneuver.

Changing Lead in Training

The formation goes into Trail from the usual 90° turn to the right or left. The leader of the formation makes a 45° turn to the left and flies that heading for approximately 20 seconds or until a turn back will place him in the rear of the formation. When the No. 1 airplane starts his 45° turn, the No. 2 plane in the Trail immediately becomes the leader of the formation and continues to fly straight ahead. At the end of 20 seconds or thereabouts, the original leader turns back and takes up the No. 3 position in his element, or the No. 6 position if in a flight of 6, and notifies the new leader that the maneuver is complete.

Landing from Vee of Squadron in Training

The formation approaches the airdrome at traffic pattern altitude, into the wind up the landing runway, at which time the wheels are ordered down by the leader and the checklist accomplished. Flaps are lowered 20° and an air speed of 135-140 mph established. The leader signals No. 3, when over the edge of the landing runway, to peel off, No. 3 acknowledging by peeling off. No. 1 follows, No. 2 fol-

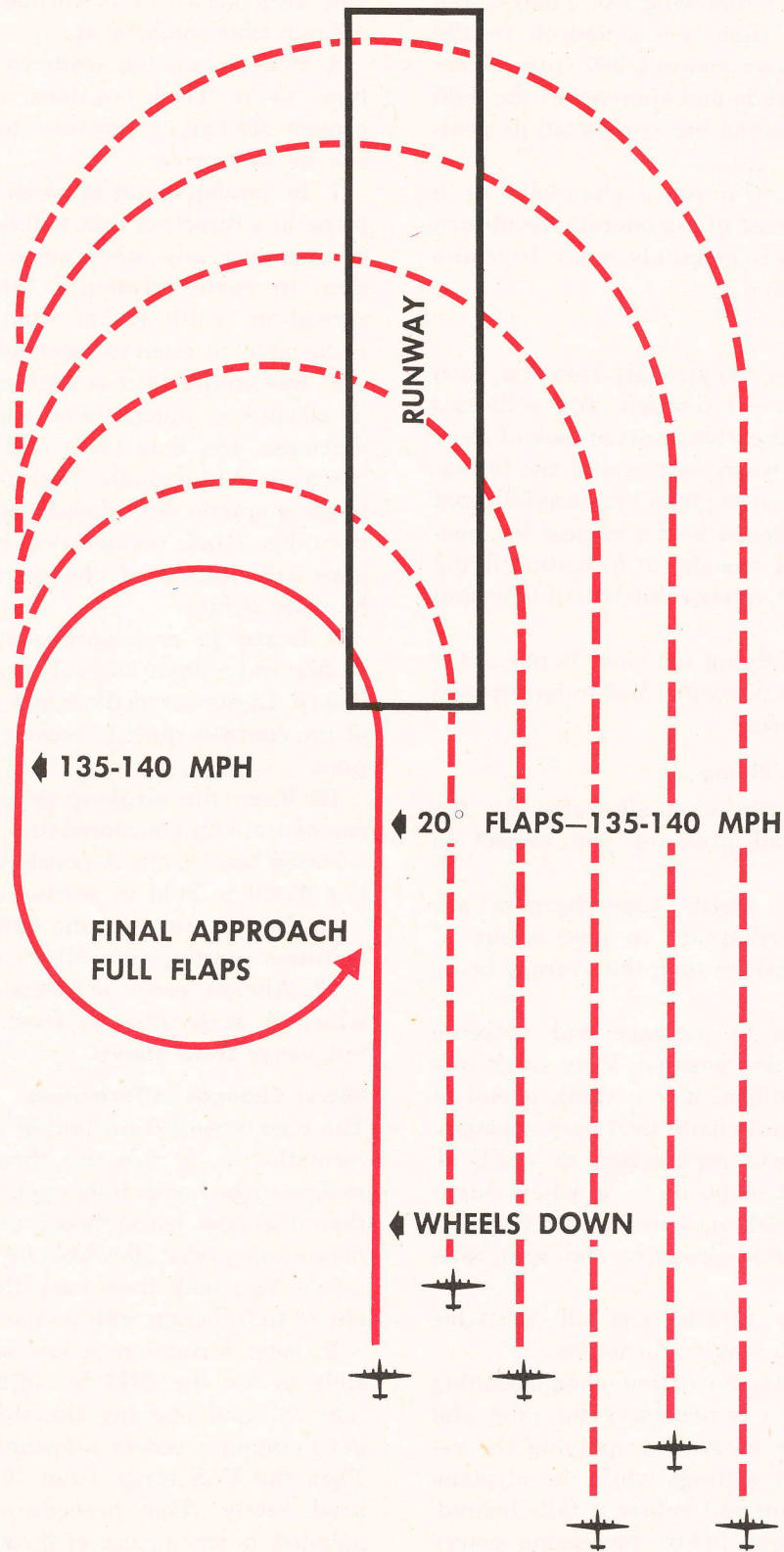

RESTRICTED

lowing No. 1, No. 6 following No. 2 and so on. If there is more than one squadron in the formation, the second makes a 360° turn above traffic pattern altitude and approaches the field after the first squadron has completed its peel-off.

Peel-off does not mean a chandelle or a dive. It should consist of a moderate, **level** turn until the airplane is definitely away from the rest of the formation.

Conclusion

This fact cannot be too strongly stated: a good formation is a safe formation. Air collisions usually result from carelessness or lack of clear understanding between members of the formation. If the simple rules given here are followed explicitly there should be no excuse for mistakes in the air. A mistake in formation flying may mean a costly, irreparable loss of lives and equipment.

Remember that flying too close is not a display of skill; it is a display of bad judgment and lack of common sense.

Tips on Formation Flying

1. Set rpm to minimum allowable for the maximum manifold pressure you expect to use.

2. At altitudes where superchargers are needed, set superchargers to give about 5" more manifold pressure than the average being used.

3. Use throttles to increase and decrease power in maintaining position. Very small corrections should suffice, if you think ahead of the airplane and anticipate necessary changes, and if you give the correction time to take hold. But when far out of position, or when catching up with a formation, increase rpm to maintain proper manifold pressure and rpm relationships.

4. When under attack, use all available power required to stay in formation.

5. In order to keep formation when operating on three engines it is necessary for pilot and copilot to react as a team in applying the required new power settings while the airplane still has momentum and before it falls behind. If you wait too long before increasing power

you drop back out of formation, and have a difficult time catching up.

6. When changing leads in practice formations or in Trail positions, avoid closing to proper formation position too rapidly. This can be dangerous.

7. In moving about in position, move the airplane in a direction that will not interfere with or endanger any other aircraft in the formation. In route formation, aircraft should be spread in width rather than depth, thereby being able to resume tight formation quickly.

8. Remember that at high altitudes the rate of closure is much more rapid than at low altitudes; you may have difficulty in slowing down quickly enough. Therefore, you have to begin stopping the closure much sooner. On the other hand, acceleration is slower, so that your anticipation of change in position must be more acute.

9. Learn to anticipate changes in position so that only slight control corrections are necessary. Large corrections and constant fighting of the controls quickly wear out even a strong pilot.

10. Keep the airplane properly trimmed to compensate for consumed fuel, crew movement, released bombs, etc. A poorly trimmed airplane is difficult to hold in position.

11. Do not use only the outboard engines to maintain position; use all 4 engines.

12. Always enter a formation from **below**, which is preferable, or from the same level, but **never from above**.

Power Changes in Formation

The recommended method of varying power in formation is to use the throttles. To do so, reduce turbo boost, fully open the throttles, and then increase turbo boost until you get the maximum power allowable for the rpm you are using. You may then vary the throttles from closed to full open with no harm to the engines.

In loose formation at low altitude, it is possible to use the TBS by adjusting it to position "8" and opening the throttles until you get maximum power allowable for your rpm. Then the TBS range from "0" to "8" may be used safely. This procedure is not recommended, however; use of throttles is preferred.

A COMBINATION OF POWER SETTINGS AND PERCENT OF POWER INCLUDING BMEP VALUES FOR VARIOUS ALTITUDES AND POWER SETTINGS THAT WILL PROVE HELPFUL IN PLANNING YOUR FORMATION FLIGHTS

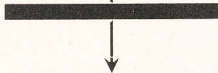
RPM	MP ALL ALT.	ARMY MODEL B-24 NAVY MODEL PB4Y-1 RPM vs. MANIFOLD PRESSURE CHART			
2550	46.0	R-1830-43 & R-1830-65 ENGINES AUTO-RICH  AUTO-LEAN			
2500	42.5				
2450	40.0				
2400	37.5				
2375	37.0				
2350	36.0				
2325	35.5				
2300	35.5				
2275	35.0				
2250	35.0				
2225	33.5				
2200	32.0				
2175	32.0	MP S.L. To 25,000	MP 25,000 & Above	28.0-30.0	
2150	31.5				
2125	31.5				
2100	31.5				
2075	31.0	MP S.L. To 15,000	MP 15,000 To 25,000	28.0	
2050	31.0				
2025				
2000				
1975	MP S.L. To 10,000	MP 10,000 To 15,000	27.5	
1950				
1925				
1900				
1875	MP S.L. To 10,000	MP 10,000 To 15,000	MP 15,000 To 25,000	27.0	
1850					
1825					
1800					
1775	10,000	15,000	24.5	
1750	31.0	28.5	24.5	
1725	31.0	27.5	24.5	
1700	30.5	26.5	24.5	
1675	30.0	26.5			
1650	30.0	26.5			
1625	29.0	26.5			
1600	28.0	26.5			
1575	27.5	26.0			
1550	27.0	26.0			
1525	26.5	26.0			
1500	26.0	26.0			

PER CENT POWER	BHP	AUTO RICH	AUTO-LEAN				
		RPM MP BMEP	RPM MP BMEP	RPM MP BMEP	RPM MP BMEP	RPM MP BMEP	
		ALL ALT.	BELOW 10,000	To 15,000	To 25,000	Above 25,000	
MILITARY AND TAKE-OFF	1200	2700	(5 MIN.) 260°C HD. TEMP. LIMIT				
100 (Normal Rated)	1100	2550	(1 HOUR) 260°C HD. TEMP. LIMIT				
90	990	2490	For Continuous Operation at All Other Powers Do Not Exceed 232°C				
80	880	2400	IMPORTANT NOTE:				
75	825	2325	Do Not Increase MP More Than 2" Hg. Above Given Values Without Raising RPM				
70	770	2250	$BMEP = \frac{433 \times BHP}{RPM}$				
65	715	2200	2200	2200	2200	2200	
		32.0	32.0	32.0	32.0	32.0	
60	660	140	140	140	140	140	
		2050	2050	2050	2050	2050	
55	605	31.0	31.0	31.0	31.0	31.0	
		139	139	139	139	139	
50	550	1900	1900	1900	2000	2000	
		31.0	31.0	30.0	28.0	28.0	
45	495	138	138	129	119	119	
		1750	1750	1850	1900	1900	
40	440	31.0	31.0	30.0	28.0	28.0	
		136	136	129	119	119	
35	385	1650	1650	1850	1900	1900	
		30.0	28.5	27.0	26.5	26.5	
30	330	130	122	116	113	113	
		1600	1700	1850	1900	1900	
25	275	28.0	26.5	24.5	24.5	24.5	
		119	112	103	95	95	
20	220	1500	1500	1750	1750	1750	
		26.0	26.0	24.5	24.5	24.5	
15	165	111	111	95	95	95	
		111	111	95	95	95	